



# Urban Mailbox Installation Guidelines

Minnesota  
Department of  
Transportation

**RESEARCH  
SERVICES**

Office of  
Policy Analysis,  
Research &  
Innovation

Michael Marti, Primary Author  
SRF Consulting Group

**July 2010**

Research Project  
Final Report #2010MAIL



*Your Destination... Our Priority*



## Technical Report Documentation Page

1. Report No. <b>MN/RC 2010MAIL</b>	2.	3. Recipients Accession No.	
4. Title and Subtitle <b>Urban Mailbox Installation Guidelines</b>	5. Report Date		
	6. <b>July 2010</b>		
7. Author(s) <b>Michael Marti, Renae Kuehl</b>	8. Performing Organization Report No.		
9. Performing Organization Name and Address <b>SRF Consulting Group, Inc. One Carlson Parkway North, Suite 150 Minneapolis, Minnesota 55477-4443</b>	10. Project/Task/Work Unit No.		
	11. Contract (C) or Grant (G) No. <b>RIC Task 6b</b>		
12. Sponsoring Organization Name and Address <b>Minnesota Department of Transportation Research Services Section 395 John Ireland Boulevard MS 330 St. Paul, Minnesota 55155</b>	13. Type of Report and Period Covered <b>Final Report</b>		
	14. Sponsoring Agency Code		
15. Supplementary Notes <a href="http://www.lrrb.org/PDF/2010MAIL.pdf">http://www.lrrb.org/PDF/2010MAIL.pdf</a> <a href="http://www.lrrb.org/PDF/2010MAILB.pdf">http://www.lrrb.org/PDF/2010MAILB.pdf</a> is the brochure			
16. Abstract (Limit: 250 words)  As a supplement to the rural mailboxes brochure, the following information was provided by the City of Eagan as an example to provide guidance for urban mailbox installation. The city developed the following documents to educate the city council and residents on the need for proper mailbox installation: <ul style="list-style-type: none"> <li>- Standard Plate – Mail and Paper box installation guidelines</li> <li>- Memo to Mayor and City Councilmembers – Summary of need to standardize mailboxes to reduce damage due to winter maintenance.</li> <li>- Resident notice flyer – sent to residents with non-complying mailboxes notifying them of the need to modify their mailbox to avoid damage due to winter maintenance.</li> </ul>			
17. Document Analysis/Descriptors <b>Mailbox Mailbox installation Urban mailboxes</b>		18. Availability Statement <b>No restrictions. Document available from: National Technical Information Services, Alexandria, Virginia 22312</b>	
19. Security Class (this report) <b>Unclassified</b>	20. Security Class (this page) <b>Unclassified</b>	21. No. of Pages <b>7</b>	22. Price

Minimum Height – 48 Inches above street level

Address must be on side of box from which carrier approaches in letters a minimum of one inch high. (or on the front where boxes are grouped).

Front of Mail Box  
Behind  
Back of Curb

48"

Front of Paper Boxes shall not  
Extend Forward  
of Vertical Post  
(If lower than 48")

"Safety Clear  
Zone"

10"



City of Eagan

Engineering Department

### MAIL & PAPER BOX INSTALLATION GUIDELINES

REVISED

8/06

STANDARD  
PLATE

610





A Typical Community Mailbox at Risk of Being Struck by Winter Maintenance Equipment (too low and forward of back of curb)

**TO: MAYOR AND CITY COUNCILMEMBERS  
THOMAS L. HEDGES, CITY ADMINISTRATOR**

**FROM: THOMAS A. COLBERT, DIRECTOR OF PUBLIC WORKS  
TOM STRUVE, SUPT. OF STREETS, EQUIPMENT**

**DATE: DECEMBER 7, 2006**

**SUBJECT: MAIL BOX PROBLEMS RELATED TO CITY  
WINTER MAINTENANCE PROGRAMS**

**EXECUTIVE SUMMARY**

Eagan’s public works managers are struggling with how to deal with distressed or out of specifications mailboxes damaged in the process of winter maintenance operations. Following is a summary of proposed proactive changes in Current City Policy.

1. Revise standard City Plate more clearly setting mailbox standards
2. Distribute information about the new policy for mailbox hits and inform residents/owners of mailboxes that are at risk
3. Develop a program that would provide residents an opportunity to have mailboxes in their residential neighborhoods refurbished contractually as a part of the neighborhood overlay programs.

**BACKGROUND**

As our community matures, Eagan’s winter maintenance operations are more and more impacted by mailboxes that are aging and are/were installed improperly. At the same time, customer service expectations have risen for our customers/citizens to the point that referring to an obscure mailbox standard that is not readily available to the public is no longer effective in dealing with the problem.

The community is blanketed with mailboxes of every different size/type. Many individual homeowners take great pride in their personal amenities and mailboxes that border Eagan streets in public boulevards. Some of these residents have very expensive and unique mailboxes; others have marginally acceptable mailboxes in very poor condition, and, still others have boxes that were installed by the developers of their unique neighborhoods. In every case, if snow and ice control equipment comes in contact with their mailboxes, they expect replacement or at least repair.

**Past Policy** has been to inform residents who call to report damage of the US Post Office specifications and the City Standard Plate requiring a minimum of 48” from the front bottom corner of the mailbox to the valley of the curb and the need for the front corner to be located behind the back of the curb. Residents are informed that if their mailbox did not meet these specifications, no repairs or replacement will occur. *Very seldom is this acceptable as a solution to the problem.* Residents typically ***insist*** that repairs are made or replacement occurs.

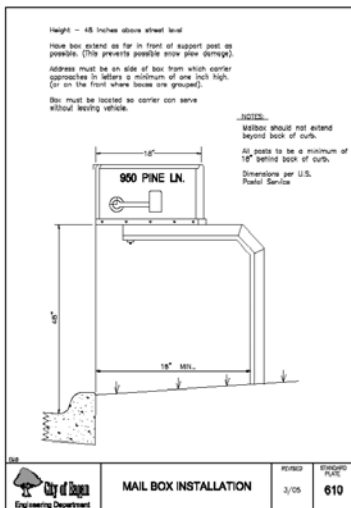

Current City Standard Plate For Mailbox installation



***It is important to note*** that it is very much the exception that City equipment comes into contact with mailboxes that are installed providing the recommended 48" *clear zone*. Virtually all mailboxes damaged during plowing operations are installed too low or forward of the back of the curb.

**Mailbox Hits**    2005-6 - Fifteen  
                          2004-5 - Eighteen  
                          2003-4 - Forty-two

**1. NEW STANDARD PLATE**

An ideal mailbox design has been adopted/installed by the Manley Developers in new developments adjacent to Dodd Rd. south of Cliff Road. We have incorporated this design into a new, easy to understand, standard City Mailbox Plate. (please see attached draft new standard City Plate for mailboxes)



Another Community Mailbox at Risk of Being Struck by Winter Maintenance Equipment (too low and forward of back of curb)



Example of Community Mailboxes Where Paper Boxes Were Struck by Winter Maintenance Equipment (too low and forward of back of curb)



Mailboxes Installed in Manley Addition (Dodd Rd. south of Cliff Rd)





Another Community Mailbox at Risk of Being Struck by Winter Maintenance Equipment

(too low and forward of back of curb)



New Manley Mailbox Construction/Design Providing 48" Clear Zone For Winter Maintenance Operations

**2. CHANGES TO THE CURRENT POLICY FOR MAILBOX HITS-  
(Informing Residents that Their Current Mailboxes are at Risk)**

**From:** City of Eagan Snow and Ice Policy for City Streets (pls see attachment)  
(Adopted by City Council on December 20, 1999)

**IV. BOULEVARD CONSIDERATIONS**

- A. Sect. B. The City replaces mailboxes that are damaged, broken, or knocked down only if there was a direct hit by a City plow or City vehicle provided the mailbox was installed and maintained to City and postal specifications. Those specifications require mailboxes be located at least 48" above the street level with the forward bottom corner located behind the back of the curb. Residents/owners notified by the City via U.S. Mail about mailboxes that do not meet specifications are responsible to repair/maintain mailboxes in the event of contact with City Snow and Ice Equipment.

*City Maintenance Managers are planning incremental distribution of copies of the new revised Standard Mailbox Plate along with specific information about individual mailboxes that need re-furbishing to residents throughout the community. Personnel will canvas sections of the City and notices will be mailed to residents/owners providing information and support resources as necessary to attempt to bring all community mailboxes to a standard that will prevent future contact/damage. (please see attached draft flyers to be distributed)*

\*Support resources may include providing a list of City approved contractor(s) who are trained to install mailboxes per City specifications.

**A NEW PROGRAM WILL PROVIDE RESIDENTS AN OPPORTUNITY TO HAVE MAILBOXES IN THEIR RESIDENTIAL NEIGHBORHOODS REFURBISHED CONTRACTUALLY AS A PART OF THE NEIGHBORHOOD OVERLAY PROGRAMS.**

City representatives are preparing to provide the opportunity at the time of Residential Neighborhood Meetings (prior to Public Hearings) for residents to learn about the possibility of refurbishing entire neighborhoods with mailboxes per City Standard in conjunction with our neighborhood refurbishment program (overlays).

This 20 year time frame may be ideal for the life cycle of a typical mailbox. Additionally, this pro-active initiative will fit well with already in place refurbishing of signage, notification of sightline obstructions and removal of boulevard amenities encroaching in rights of way currently being addressed at the 20 year overlay interval.

As always, we would welcome the opportunity to provide any additional information that the City Council may need.

Respectfully,

Tom Colbert, Director of Public Works  
Tom Struve, Superintendent of Street and Equipment



# Please Note...



**City of Eagan** winter maintenance operations require that residential mailboxes provide a 48" CLEAR ZONE (see attachment) between the bottom front corner of the mailbox structures/paper boxes and the valley of the curb. Structures must also be located behind the back of the concrete curbing.

*YOUR MAILBOX at:*

*IS IN DANGER OF DAMAGE BECAUSE:*

- Front bottom structures are too low (less than 48")*
- Mailbox/paper boxes are located forward of the back of the curb.*
- Is in need of refurbishing (aging/deteriorating post or structure may not stand impact of snow from plow)*

PLEASE make appropriate changes/repairs as needed.

The City of Eagan will not repair/replace your mailbox if damaged by winter maintenance activities in its current condition

**Questions? Please contact**

Kurt Schlegel or Tim Plath, Streets Maintenance  
651-675-5300

-----  
(**Tear off here** and mail to: Eagan Central Maint., 3501 Coachman Pt., Eagan MN 55122)  
Or notify us via e-mail at: [Tplath@cityofeagan.com](mailto:Tplath@cityofeagan.com)

(**Please notify us** when refurbishing/replacement occurs for a compliance inspection)

NAME \_\_\_\_\_

ADDRESS \_\_\_\_\_

DAY TIME PHONE \_\_\_\_\_