



Implementation, Training, and Outreach for MnDOT Pavement Marking Tool - Phase II

Minnesota
Department of
Transportation

**RESEARCH
SERVICES**

Office of
Policy Analysis,
Research &
Innovation

Omar Smadi, Principal Investigator
Center for Transportation Research and Education
Iowa State University

October 2012

Research Project
Final Report 2012-31

Your Destination... Our Priority



To request this document in an alternative format, please contact the Affirmative Action Office at 651-366-4723 or 1-800-657-3774 (Greater Minnesota); 711 or 1-800-627-3529 (Minnesota Relay). You may also send an e-mail to ADArequest.dot@state.mn.us.

(Please request at least one week in advance).

Technical Report Documentation Page

1. Report No. MN/RC 2012-31	2.	3. Recipients Accession No.	
4. Title and Subtitle Implementation, Training, and Outreach for MnDOT Pavement Marking Tool – Phase II		5. Report Date October 2012	
		6.	
7. Author(s) Omar Smadi and Neal Hawkins		8. Performing Organization Report No.	
9. Performing Organization Name and Address Center for Transportation Research and Education Iowa State University 2711 South Loop Drive, Suite 4700 Ames, IA 50010-8664		10. Project/Task/Work Unit No.	
		11. Contract (C) or Grant (G) No. (C) 89256 (WO) 8	
12. Sponsoring Organization Name and Address Minnesota Department of Transportation Research Services 395 John Ireland Boulevard, MS 330 St. Paul, MN 55155		13. Type of Report and Period Covered Final Report	
		14. Sponsoring Agency Code	
15. Supplementary Notes http://www.lrrb.org/pdf/201231.pdf			
16. Abstract (Limit: 250 words) The objective of this project was to fully implement the Pavement Marking Management Tool by incorporating retroreflectivity and striping data (MnDOT and contractors) and simplifying the process of data collection, storage, and analysis. As part of achieving full implementation, the researchers provided training to MnDOT central office staff and staff in each of the districts. Improved pavement marking management has the potential to reduce MnDOT's costs, improve pavement marking performance, and in return provide a more efficient and safe driving experience for the traveling public. The result of this effort included a web-portal for submitting pavement marking data (paint and retroreflectivity), a geographic information system (GIS) web based tool to manage, view, and create reports on pavement marking data, and training on the data collection and tool. This technical memorandum presents project findings by task.			
17. Document Analysis/Descriptors Road markings, Retroreflectivity, Data processing, Web based tools		18. Availability Statement No restrictions. Document available from: National Technical Information Services, Alexandria, Virginia 22312	
19. Security Class (this report) Unclassified	20. Security Class (this page) Unclassified	21. No. of Pages 67	22. Price

Implementation, Training, and Outreach for MnDOT Pavement Marking Tool – Phase II

Final Report

Prepared by:

Omar Smadi
Neal Hawkins

Center for Transportation Research and Education
Iowa State University

October 2012

Published by:

Minnesota Department of Transportation
Research Services
395 John Ireland Boulevard, MS 330
St. Paul, Minnesota 55155

This report represents the results of research conducted by the authors and does not necessarily represent the views or policies of the Minnesota Department of Transportation or Iowa State University. This report does not contain a standard or specified technique.

The authors, the Minnesota Department of Transportation, and Iowa State University do not endorse products or manufacturers. Any trade or manufacturers' names that may appear herein do so solely because they are considered essential to this report.

Acknowledgments

The authors would like to thank the Minnesota Department of Transportation for sponsoring this research and the outstanding members of the Technical Advisory Panel and other staff for their input, dedication, and insightful feedback throughout the project. This includes:

Mitch Bartelt	MnDOT – <i>Technical Liaison</i>
Alan Rindels	MnDOT – <i>Project Coordinator</i>
Peter Buchen	MnDOT
Bruce Daniel	MnDOT
Mark Dreyer	MnDOT
Dave Gustafson	MnDOT
John Harrison	MnDOT
Kenneth Johnson	MnDOT
Sheila Johnson	MnDOT
Brad Lechtenburg	MnDOT
Charlie McCarty	MnDOT
Kay McDonald	MnDOT
Mathew Porter	MnDOT
Karen Scott	MnDOT
Paul Weinberger	MnDOT
Gregory Wentz	MnDOT

Table of Contents

Chapter 1	Introduction.....	1
Chapter 2	Findings by Task.....	3
Task 1.A	PMMT Implementation Plan.....	3
	<i>For the PMMT to become Operational, the Following Steps Need to be Completed.</i>	<i>3</i>
	<i>Future Research.....</i>	<i>3</i>
	<i>Strategy towards Full Implementation.....</i>	<i>3</i>
Task 1.B	PMMT Data Flow and Process.....	5
Task 2	Handheld Retroreflectivity Data Collection Protocol.....	5
	<i>Introduction.....</i>	<i>5</i>
	<i>Recommended Protocol.....</i>	<i>5</i>
Task 3	Initial PMMT Training and Outreach.....	7
	<i>Meeting Locations.....</i>	<i>7</i>
	<i>Meeting Information.....</i>	<i>8</i>
	<i>Meeting Feedback.....</i>	<i>8</i>
Tasks 4, 5, and 6B	Operational PMMT and Data Portal.....	9
	<i>Minnesota DOT Pavement Marking Management System – Submitting Data.....</i>	<i>10</i>
	<i>Minnesota DOT Pavement Marking Management System – Web Application.....</i>	<i>16</i>
Task 6A	Investigate Automation of Striping Data.....	37
Task 7	District Training.....	41
Chapter 3	Conclusions.....	42
Appendix A – PMMT Data Process/Flow Chart		
Appendix B – MnDOT Data Logging System (DLS) Specifications		

List of Figures

Figure 1. Handheld Retroreflectorometer	5
Figure 2. Data Collection Points on a Multi-lane Roadway	6
Figure 3. Example Plot from Skip Line Controller Data (Plotted by Truck Speed).....	37
Figure 4. Paint Coverage Areas	38
Figure 5. Magnified Areas for Paint	39
Figure 6. Areas with Application Speed over 15 mph.....	40

Executive Summary

Providing visible pavement markings at the center and edges of roadways are critical to public safety, helping to prevent accidents by delineating traffic lanes more clearly and providing information to drivers about lane changing and passing opportunities. MnDOT faces considerable challenges in maintaining visible pavement markings across the state transportation network given the damage these markings receive from winter maintenance activities and wear due to vehicular traffic. Managing pavement marking visibility has the potential to reduce MnDOT costs, improve pavement marking performance through selecting better materials, and in return provide a more efficient and safe driving experience for the traveling public.

This project accomplished a major MnDOT objective which is the implementation of a pavement marking management web application tool. Based on a previous effort “Developing and Implementing Enhanced Pavement Marking Management Tools for MnDOT – Phase I”, this Phase II work delivered the critical implementation efforts needed to facilitate the usage and effectiveness of the Pavement Marking Management Tool (PMMT).

Implementation of the PMMT begins with data, more specifically, pavement marking retroreflectivity and striping data which is incorporated into an ORACLE database. Retroreflectivity provides a measure of the pavement markings visibility under dark conditions on unlighted roadways. The striping data provides information relative to when, where, and how each roadway was painted which supports an analysis of performance over time. Since both MnDOT staff and their Contractors measure retroreflectivity and install markings on MnDOT roadways, implementation of the PMMT included simplifying the process of collecting and submitting data, storing these data, and in providing staff access to the data to turn it into useful information for analysis.

Training was an essential implementation activity for the PMMT and was divided up into an initial set of training sessions and final training. The initial training was conducted for central office, District 6, and Metro District staff and provided feedback on how the field data (retroreflectivity and paint) would be submitted to the PMMT and the quality control process in place to address errors. Based on this feedback, the research team worked with both IT and geographic information system (GIS) staff to finalize all input automation processes, the data portal, and the operational PMMT. The final training consisted of computer based instruction on the use of the fully operational PMMT and was conducted at 5 locations across the state including staff from Central Office and each district.

As the numerous screen-shots within this report show, implementation of the web based PMMT provides MnDOT staff with the ability to input, organize, query, and most importantly turn pavement marking data into useful information. In summary, the graphic PMMT enables managing this critical safety feature at the roadway, district, and statewide level which will result in data driven decision making and ultimately a more efficient, effective, and safer roadway network for all roadway users.

Chapter 1 Introduction

The objective of the research is to fully implement the recently developed Pavement Marking Management Tool by incorporating retroreflectivity and striping data (MnDOT and contractors), and simplifying the process of data collection, storage, and analysis. As part of achieving full implementation, the researchers provided training to MnDOT central office staff and staff in each of the districts. Improved pavement marking management has the potential to reduce MnDOT's costs, improve pavement marking performance, and in return provide a more efficient and safe driving experience for the traveling public. This technical memorandum presents project findings by tasks, which are noted below.

Task 1.A – Review the recommendations from the previous project recently completed for MnDOT for full implementation and develop strategies to address the required steps to move towards full implementation. A data schema of the recently developed MnDOT Pavement Marking Management Tool will be sent to MnDOT for approval. The research team will meet with the project TAP (including IT staff) to discuss the findings and finalize the implementation plan.

Task 1.B – Develop data flow process from central office, districts, striping crews, and pavement marking contractors to the ORACLE database for use by the pavement marking management web-based tool. The team will develop the processes in coordination with MnDOT enterprise geographic information system (EGIS) staff to meet the database model standards and requirements. MnDOT EGIS staff will still run the RLC process after delivery of formatted data and append records to the ORACLE database. The existing Pavement Marking Management Tool will be modified to reflect the current migration by MnDOT to ARCGIS 9.3.

Task 2 – Develop data collection protocols for using the handheld (LTL-X) devices available to the districts. The data collection protocol will define sampling rates, collection method, and frequency. The research team will work with central office and district staff to address the data collection needs, constraints in terms of time and personnel, and format.

Task 3 – Initial training: work with central staff, district 6 and metro district to conduct PMMT training and also get feedback regarding automation tasks.

Task 4 – Work with IT and geographic information system (GIS) staff to develop processes and tools to allow for automated input of pavement marking data into the ORACLE tables developed in Phase I of this project. This task will involve both central office pavement marking staff, and GIS and IT personnel. The research team will use the final implementation plan developed in Task 1 to guide the tools development process. At the conclusion of this task, the recently pavement marking management web-based developed by CTRE for MnDOT should be populated with van collected retroreflectivity data from 2007 and 2008 (additional data collected using handheld by the district staff and paint information from central striping will also be considered).

Task 5 – Work with the pavement marking contractors and MnDOT to develop a methodology to allow for proper data input utilizing the web-based process developed in Task 1.B (pavement

Task 6 – Data Automation Task:

Task 6.A – Investigate the use of monitoring technology (SkipLine controllers are used on two paint trucks in MN) to automate the collection of paint information and develop guidelines for proper data format to be followed by all districts.

Task 6.B – Work with district staff to automate data entry/interface to the pavement marking tool for both retroreflectivity (Handheld LTL-X devices) and paint information.

Task 7 – Training: work with the central office and the remaining districts (6 districts) to conduct training on the use of the PMMT and also gain feedback regarding data collection and automation processes.

Task 8 - Technical Memorandum – The technical memorandum summarizes project findings and discuss additional future steps to enhance pavement marking decision making and performance.

Chapter 2 Findings by Task

Task 1.A PMMT Implementation Plan

Review the recommendations from the previous project recently completed for MnDOT for full implementation and develop strategies to address the required steps to move towards full implementation. A data schema of the recently developed MnDOT Pavement Marking Management Tool will be sent to MnDOT for approval. The research team will meet with the project TAP (including IT staff) to discuss the findings and finalize the implementation plan.

The recommendations from the previous Phase I project were as follows:

For the PMMT to become Operational, the Following Steps Need to be Completed

1. Build ORACLE Tables (this will be completed by CO – EGIS based upon the standard format and naming convention established for the PMMT.
2. Develop retroreflectivity data flow requirements.
 - a. Data Sources:
 - i. Laserlux data from central office (does not currently include GPS)
 - ii. Handheld data from districts (some of this will not have GPS)
 - b. Data Formatting – putting the above data within the standard PMMT format for location, pavement marking and installation information. This will be completed by CO-OTSO staff.
 - c. Data Submittal – Development of the “handshake” for data transfer from CO-OTSO to the web server (CO-EGIS).
 - d. Location Formatting – CO-EGIS will use the Route Location Converter (RLC) to convert location information into the MnDOT GIS web server format.
3. Implementation – Determine web server needs, number of users, and other features/business rules to support access to the PMMT.

Future Research

Further enhancements to the PMMT will include:

1. Striping Data - Incorporation of striping data from both CO and Contract Striping which will give staff the ability to match marking performance with installation information.
2. Standardize Handheld Data Collection - Developing data collection protocols for district staff to use when collecting retroreflectivity information using the handheld devices.
3. Standardize Mobile Data Collection – Identify opportunities to improve the Laserlux data in terms of data quality (less variability), location information (GPS), and incorporation of this information into the PMMT database.

Strategy towards Full Implementation

The following work plan addresses the next steps and future research identified within the Phase 1 report.

Task 2 – Develop data collection protocols for using the handheld (LTL-X) devices available to the districts. The data collection protocol will define sampling rates, collection method, and frequency. The research team will work with central office and district staff to address the data collection needs, constraints in terms of time and personnel, and format.

Task 3 – Initial training: work with central staff, district 6 and metro district to conduct PMMT training and also get feedback regarding automation tasks.

Task 4 – Work with IT and GIS staff to develop processes and tools to allow for automated input of pavement marking data into the ORACLE tables developed in Phase I of this project. This task will involve both central office pavement marking staff, and GIS and IT personnel. The research team will use the final implementation plan developed in Task 1 to guide the tools development process. At the conclusion of this task, the recently pavement marking management web-based developed by CTRE for MnDOT should be populated with van collected retroreflectivity data from 2007 and 2008 (additional data collected using handheld by the district staff and paint information from central striping will also be considered).

Task 5 – Work with the pavement marking contractors and MnDOT to develop a methodology to allow for proper data input utilizing the web-based process developed in Task 1.B (pavement marking installation information) into the MnDOT Pavement Marking Tool.

Task 6 – Data Automation Task:

Task 6.1 – Investigate the use of monitoring technology (SkipLine controllers are used on two paint trucks in MN) to automate the collection of paint information and develop guidelines for proper data format to be followed by all districts.

Task 6.2 – Work with district staff to automate data entry/interface to the pavement marking tool for both retroreflectivity (Handheld LTL-X devices) and paint information.

Task 7 – Training: work with the central office and the remaining districts (6 districts) to conduct training on the use of the PMMT and also gain feedback regarding data collection and automation processes.

Task 1.B PMMT Data Flow and Process

The research team developed PMMT data flow processes from central office, districts, striping crews, and pavement marking contractors to the ORACLE database for use by the pavement marking management web-based tool. These were developed in coordination with MnDOT EGIS staff to meet the database model standards and requirements. The developed diagrams, flow processes, and schema's are included within Appendix A.

Task 2 Handheld Retroreflectivity Data Collection Protocol

Introduction

Pavement marking retroreflectivity condition information is collected by MnDOT staff using both handheld and mobile (van) equipment. This information will serve as the primary pavement marking performance metric within the MnDOT Pavement Marking Tool (a GIS based tool to view and query condition information).

Specific to the handheld devices (see Figure 1) a protocol for data collection is needed to ensure consistency on when, where, and how the field data are obtained. This effort is identified within the project scope as follows.



Figure 1. Handheld Retroreflectometer

Recommended Protocol

This protocol is specific to the collection of network level pavement marking retroreflectivity information to be incorporated within the MnDOT pavement marking database. The research team investigated various sources to develop this recommended protocol. These included current ASTM practices, Iowa DOT data collection protocol, and other available information. This information is summarized below:

Sampling Frequency:

ASTM Practice:

The currently proposed practice calls for taking 20 retroreflective readings equally distributed over 400 feet within a 2 mile segment. This level of sampling is designed for compliance based testing on new pavement markings.

Iowa DOT Practice:

The Iowa DOT protocol collects 12 readings equally distributed over 160 feet within a 4 and/or 5 mile segment. This level of sampling is intended for network level pavement marking management.

Proposed MnDOT Practice:

In an effort to balance consistency, objectivity, and field data collection time, the following three options were considered.

Method 1 – Collect 20 readings equally distributed over 400 feet within a 4 mile segment.

Method 2 - Collect 10 readings equally distributed over 200 feet within a 2 mile segment.

Method 3 - Collect 5 readings equally distributed over 200 feet within a 2 mile segment.

Each method tries to balance the impact of variability over a segment versus the time required to collect the data. Of the three, the research team recommends Method 1 which results in a more representative value (given that we are collecting 20 readings over 400 feet) and minimizes crew exposure and time. The sampling frequency was modified to be

Recommendation: Method 1 but adjusted for MnDOT skip line spacing criteria (16 readings over 400 feet within a 4 mile segment) - see Figure 2.

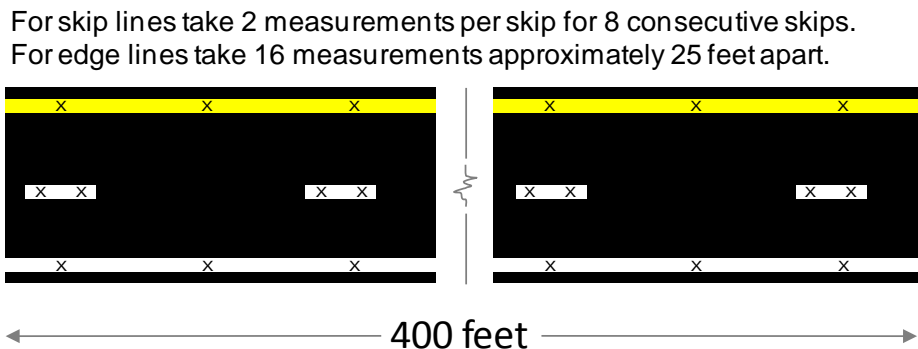

Figure 2. Data Collection Points on a Multi-lane Roadway

Data Collection Procedure:

When – Annually during the months of April, May and June (prior to the paint season). This time frame allows the Districts/Central Striping to utilize the retroreflectivity information to plan for their summer paint season.

Where – For consistency over time, the research team recommends collecting the data at the same locations each year (using milepost markers as a reference). Accuracy and efficiency can be improved by creating a database containing route and milepost locations where data are to be collected. These databases should be uploaded into each handheld instrument by district.

How – The recommended field data collection process follows:

1. Calibrate the handheld instrument according to the manufacturers' recommendations.
2. Locate the field sampling locations using the milepost marker. Care should be taken to select areas that are typical of the marking section, avoiding areas of paint tracking or contamination.
3. All measurements should be taken in the direction of travel (with the milepost). On the centerline of undivided highways, measurements should be made in both directions of travel. If two center marking lines exist, alternate between each line and by travel direction.
4. On all traffic lines take the reflectivity reading centered on the line. On edge lines take 16 equally spaced readings within the 400 foot sampling area regardless of the condition of the line. On lane lines, take 2 readings on each skip for 8 consecutive skips, see Figure 2.
5. Data entry for handheld instrument
 - a. Set the device to average based on 16 readings.
 - b. Select route and milepost from the pre-loaded list.
 - c. Enter direction of travel "1" with milepost and "2" against the milepost. On two-lane roadways, the yellow centerline direction is always recorded as a "1".
 - d. Select the line type to be measured.
 - e. Select the marking material type (if known).
 - f. Take retroreflective readings using the defined procedure.

Task 3 Initial PMMT Training and Outreach

This included working with central staff, district 6 and metro district to conduct initial PMMT training and to receive feedback regarding automation tasks. A summary of the two training sessions follows.

Meeting Locations

Training and feedback sessions were held as follows:

District 6 (Rochester) – This meeting was held on March 10th, 2010 with 12 participants (11 from District 6 and 1 from District 7) which included a mix of positions (Central Office, District technical, and District field staff).

Metro District (Arden Hills Training Facility) – This meeting was held on March 11th, 2010 with

18 participants who included a mix of positions (Central Office, District technical / field / and management staff).

Meeting Information

Each training/feedback session included a presentation by CTRE staff covering the following topics:

1. Pavement Marking Practices
 - a. Introduction
 - b. Challenges
 - c. Retroreflectivity
 - d. MnDOT Pavement Marking Practices
 - i. Material Selection
 - ii. Equipment
 - iii. Operations
 - iv. Management
2. Pavement Marking Retroreflectivity Versus Safety
3. Data Collection
4. MnDOT Pavement Marking Management Tool
 - a. Overview
 - b. Data Structure
 - c. Demonstration
 - i. Data Input
 - ii. Tool Operation
 - iii. Reports and Queries
 - iv. Hands-on

Meeting Feedback

Participant feedback and comments is summarized below:

A. Feedback/background regarding MnDOT Pavement Marking Practices:

District 6:

- Interstate, 4-lane, and new construction is typically epoxy with an expected life of around 4 years.
- Interstate lane line is tape.
- Maintain epoxy for two cycles then apply latex.
- Latex is 20 mil initially and around 12 mil maintenance.
- Two-lane roads are usually latex and are painted each year.
- District has experimented with 6” stripes based on crash data.
- On new seal-coat, the district experimented with a double epoxy being applied one week after installation.

Metro District:

- Operate both latex and epoxy trucks.
- Latex truck is equipped with a skip line controller (allows for automated capture of striping data).

- Significant challenges due to traffic and roadway conditions.
 - Have a modified paint carriage which is very effective for bead placement around curves.
- B. Feedback/discussion on MnDOT Data Collection Protocol
- Discussed the data collection protocol as follows:
 - For a 4 mile segment, select a 400 foot segment which begins at a milepost marker. For this segment:
 - Take 2 measurements per skip for 8 consecutive skips, and
 - On edge line, take 16 measurements approximately 25 feet apart.
 - The group discussed this process from a field staff/efficiency perspective. The question was specific to the order each line would be measured as you travel along the segment. For example, should staff take readings on an edge line first then travel back to do the center-line or should they read both the edge and center line at the same time as they travel down the road. After this discussion, the group felt that MnDOT should develop a field data collection procedure which provides guidance on the overall field data collection process.
 - Demonstrated the use of the LTL-X handheld retroreflectivity device.
- C. Feedback/discussion on MnDOT Pavement Marking Management Tool (PMMT)
- The districts would like to use the tool to compare the performance of different products and installation methods. A discussion followed where the importance of collecting retro data, installation information, and material type is crucial in meeting this need.
 - Add meta-data to the information e.g. what does I35_E mean?
 - Provide a distinction between “Mobile” and “Handheld” retro data on the map.
 - Modify the tool to allow each district to view their district data rather than start with the statewide map view.
 - Define retroreflectivity ranges e.g. green = good.
 - Arrange the graph data by date from old (left) to new (right)
 - Investigate possibility of combining both white and yellow data within one table (might be problematic given that each color has a different retroreflectivity threshold). The research team will work with the technical panel to address this issue.
 - Discussed minimal data requirements for contractor applied paint and how this fits within the MnDOT PMMT.
 - Discussed the feasibility of developing a planning function which would allow the districts and CO striping to develop pavement marking plans (where, material type, estimated cost, time frame). This is outside the scope of this current project but the research team will provide a write-up on this concept as discussed and will present this to the technical panel for further discussion.

Tasks 4, 5, and 6B Operational PMMT and Data Portal

These tasks covered the development of the PMMT tool and a data collection portal for paint and retroreflectivity data. The following user manuals cover these tools.

Minnesota DOT Pavement Marking Management System – Submitting Data

1. The main web portal for PMMT allows you to enter the data uploading application or interactive web map application.

The screenshot shows the 'Mn/DOT Interactive Pavement Marking Main' web application in a Windows Internet Explorer browser window. The address bar shows 'http://localhost/MnPMMT/index.htm'. The page features the Minnesota Department of Transportation logo and navigation links like 'Home | About Mn/DOT | Doing Business | Getting Around | 511'. The main heading is 'Interactive Pavement Marking Map' with a sub-heading 'View, save and print statewide maps and data involving paint markings and reflectivity of pavement on all state roads in Minnesota. Upload pavement marking and reflectivity data.' Below this are four tabs: 'Upload Striping and Retroreflectivity Data', 'Interactive Pavement Marking Map', 'Help Pages', and 'Contact Us'. The 'Interactive Pavement Marking Map' tab is active, displaying a 'Launch Interactive Pavement Marking Map' link. The page is divided into three columns. The left column contains links for 'MetaData', 'Disclaimer, legal notices and policies', and 'Go to Top'. The middle column has 'Instructions' (explaining the map's scale of 1:24000 and providing a 'more' link), 'Using the Tools:' (listing a 'Basic Toolbox' for zooming, panning, and information), and 'Getting Started' (guiding users on how to use the map). A map of Minnesota is shown at the bottom of the middle column, with labels for 'BEMIDJI' and 'DOROTHY'. The right column contains 'Web Browser Requirements' (recommending Internet Explorer 6.x), 'Viewing the Site' (specifying a resolution of 1024 * 768), 'Printing' (noting that pop-up blocking must be disabled), 'Pop-up Blocking' (explaining how to allow pop-ups), and 'Available Layers Include:' (listing Roads, Railroads, Airport Runways, Navigable Waters, State Boundary, County Boundaries, Municipal Boundaries, and Mn/DOT Districts).

2. Select the Upload Striping and Retroreflectivity Data link at the top of the site to enter the data uploading site.

Mn/DOT Pavement Marking - Upload Striping and Retroreflectivity Data - Windows Internet Explorer

http://localhost:1308/Index.aspx

Mn/DOT Pavement Marking - Upload Striping and Retr...

Minnesota Department of Transportation

Home | About Mn/DOT | Doing Business | Getting Around | 511

Mn/DOT A to Z | Contact | Simple Search | Advanced Search

Upload Striping and Retroreflectivity Data

Upload pavement striping and retroreflectivity data for state roads in Minnesota.

[Pavement Marking Main](#) | [Interactive Pavement Marking Map](#) | [Contact Us](#)

v1.8

Input file and data format requirements are described in the files below:

- [Retroreflectivity Input Requirements \(pdf\)](#)
- [Retroreflectivity File Template \(Excel\)](#)
- [Striping Input Requirements \(pdf\)](#)
- [Striping File Template \(Excel\)](#)
- [Disclaimer, legal notices and policies](#)
- [Go to Top](#)

1. Select a file to submit.

2. Select the file type.

Retroreflectivity (Laserlux)

Retroreflectivity (Handheld)

Striping

3. Enter contact information

Email Address:

© 2000-2011 Minnesota Department of Transportation
395 John Ireland Boulevard • St. Paul, MN 55155-1899
Phone: 800/857-3774 • 800/627-3529 (TTY, Voice, ASCII)
This site best viewed with 1024X768 or greater and with Mozilla Firefox 2, Safari 3 or Internet Explorer 6 or greater.

[A to Z](#) | [Getting Around](#) | [About Mn/DOT](#) | [ADA and Accessibility](#) | [Disclaimer and Legal](#) | [Doing Business](#) | [Contact Mn/DOT](#) | [News Room](#) | [511 Traveler Service](#) | [Careers/Jobs](#) | [Northstar](#) | [Governor's Site](#)

Done Local intranet 100%

3. The upload site was requires that the Silverlight browser plug-in be installed. If your computer does not already have Silverlight installed you should be prompted to install it before the site will display properly. Note: Administrator or installer privileges may be required to install Silverlight software.
4. The left hand side of the data upload site has some helpful files available to assure that the correct data and format are submitted for processing.
 - a. Retroreflectivity Input Requirements (pdf) – This file indicates the field requirements and data structure required to submit a retroreflectivity data file successfully through the data upload portal.
 - i. Indicates required fields, data types, and code values used for specific fields.

- b. Retroreflectivity File Template (Excel) – this file is an Excel template that provides the required field restructure necessary to upload a retroreflectivity data file.
 - c. Striping Input Requirements (pdf) – This file indicates the field requirements and data structure required to submit a striping data file successfully through the data upload portal.
 - i. Indicates required fields, data types, and code values used for specific fields.
 - d. Striping File Template (Excel) – this file is an Excel template that provides the required field restructure necessary to upload a striping data file.
5. You may only submit a single data file at a time. Currently the only accepted format is a comma-delimited CSV file. The Excel template can be saved as a CSV in Excel.

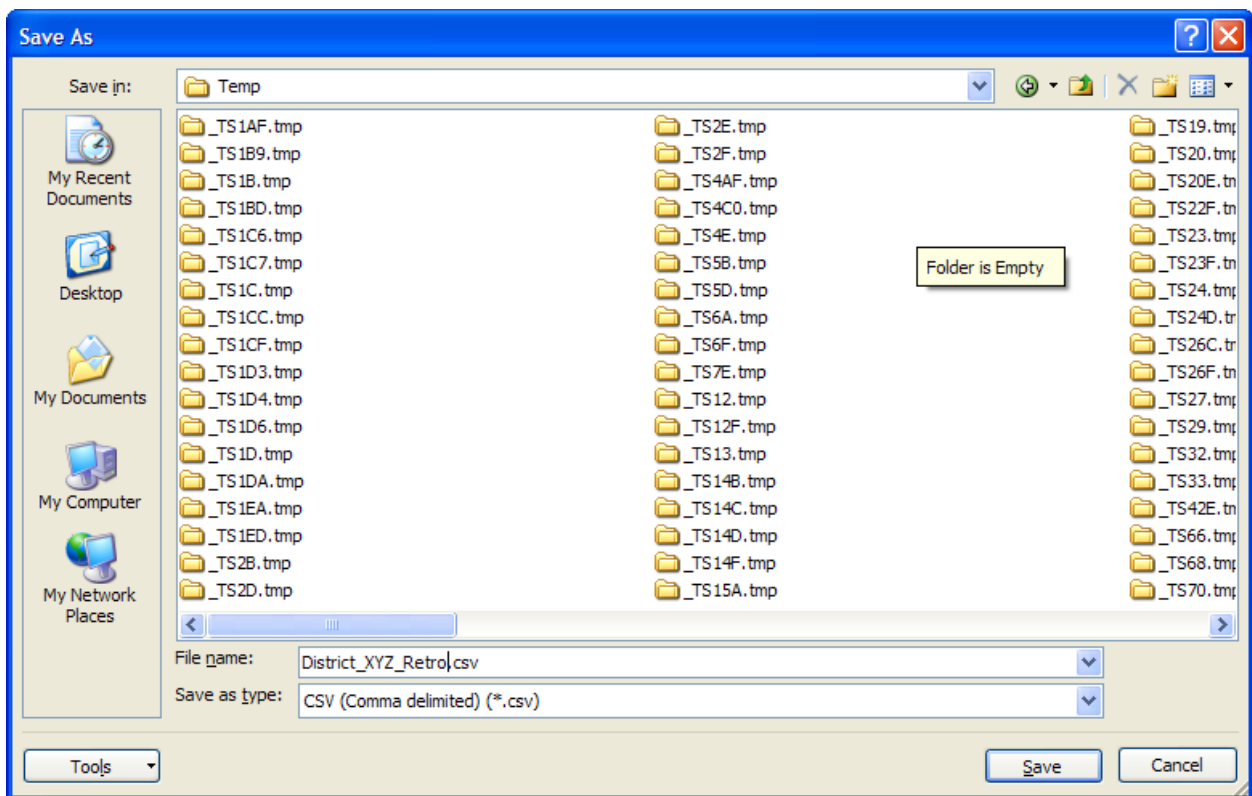

- From the Upload site select the Browse button and select the CSV data file you want to upload.

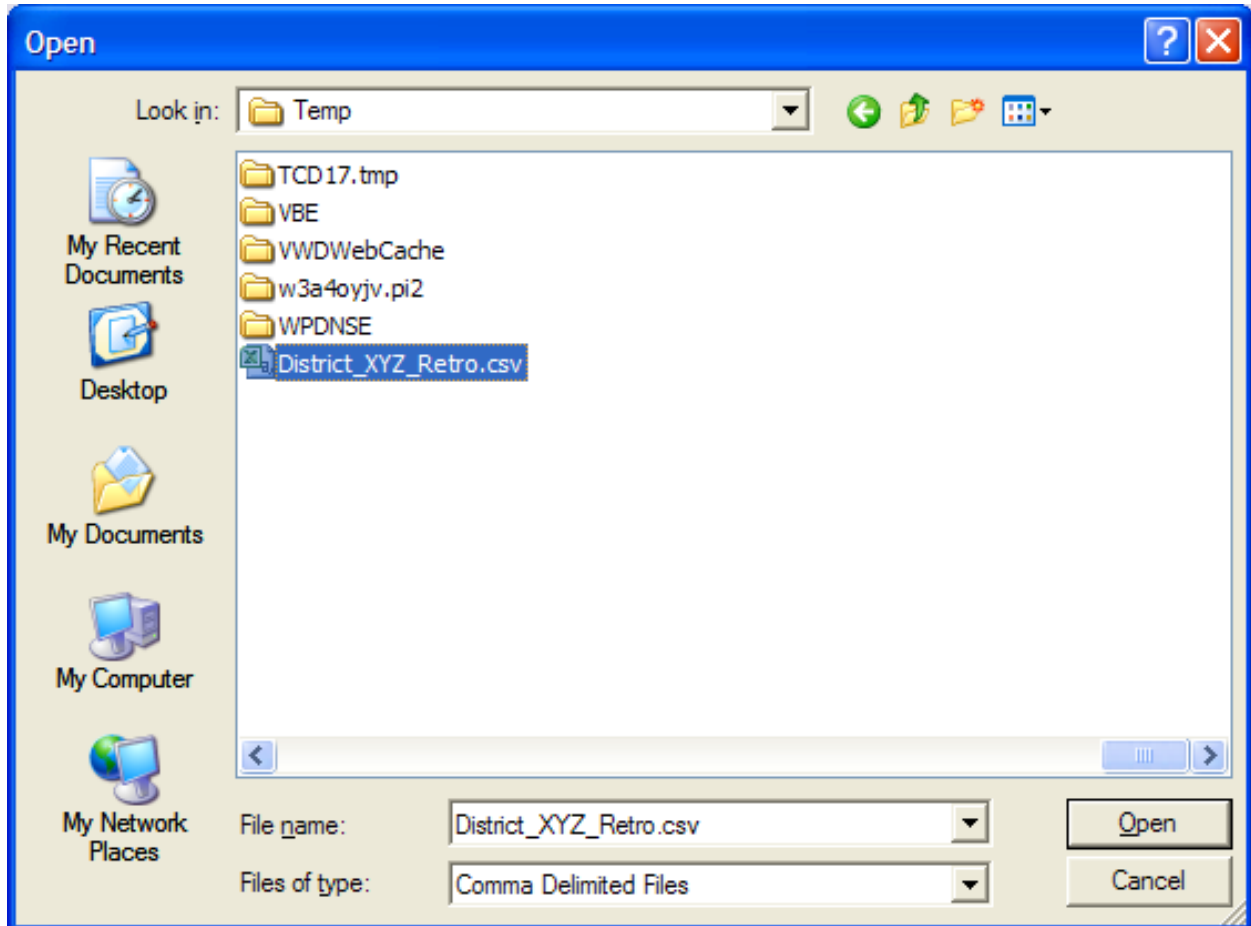

7. Select the specific data file type being uploaded and enter a valid email address that the system can respond to. The example below is an upload of a retroreflectivity data file containing Laserlux data only.

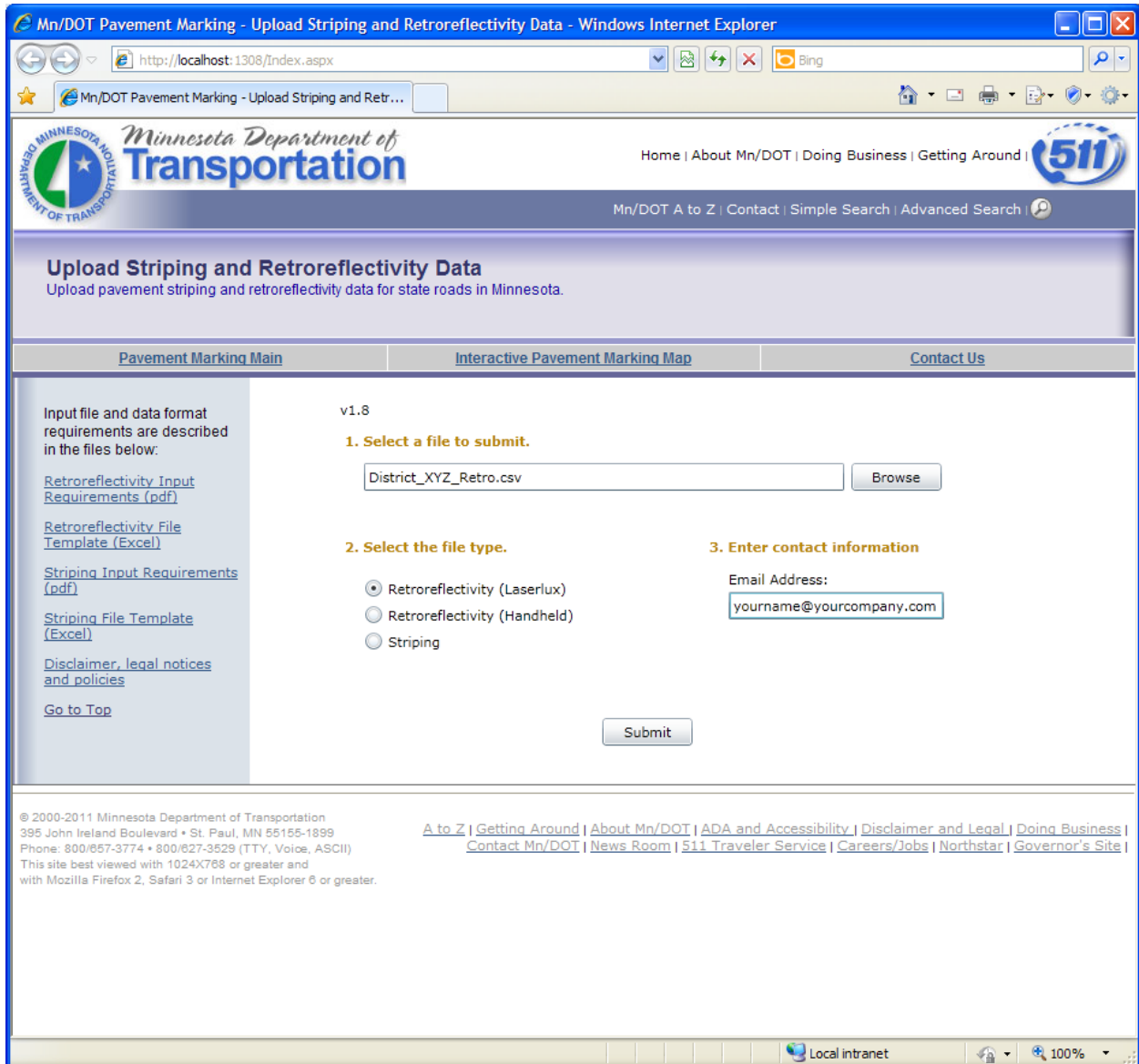

8. If submitting Striping data you will also be presented with a drop-down list that indicates where the data originated.

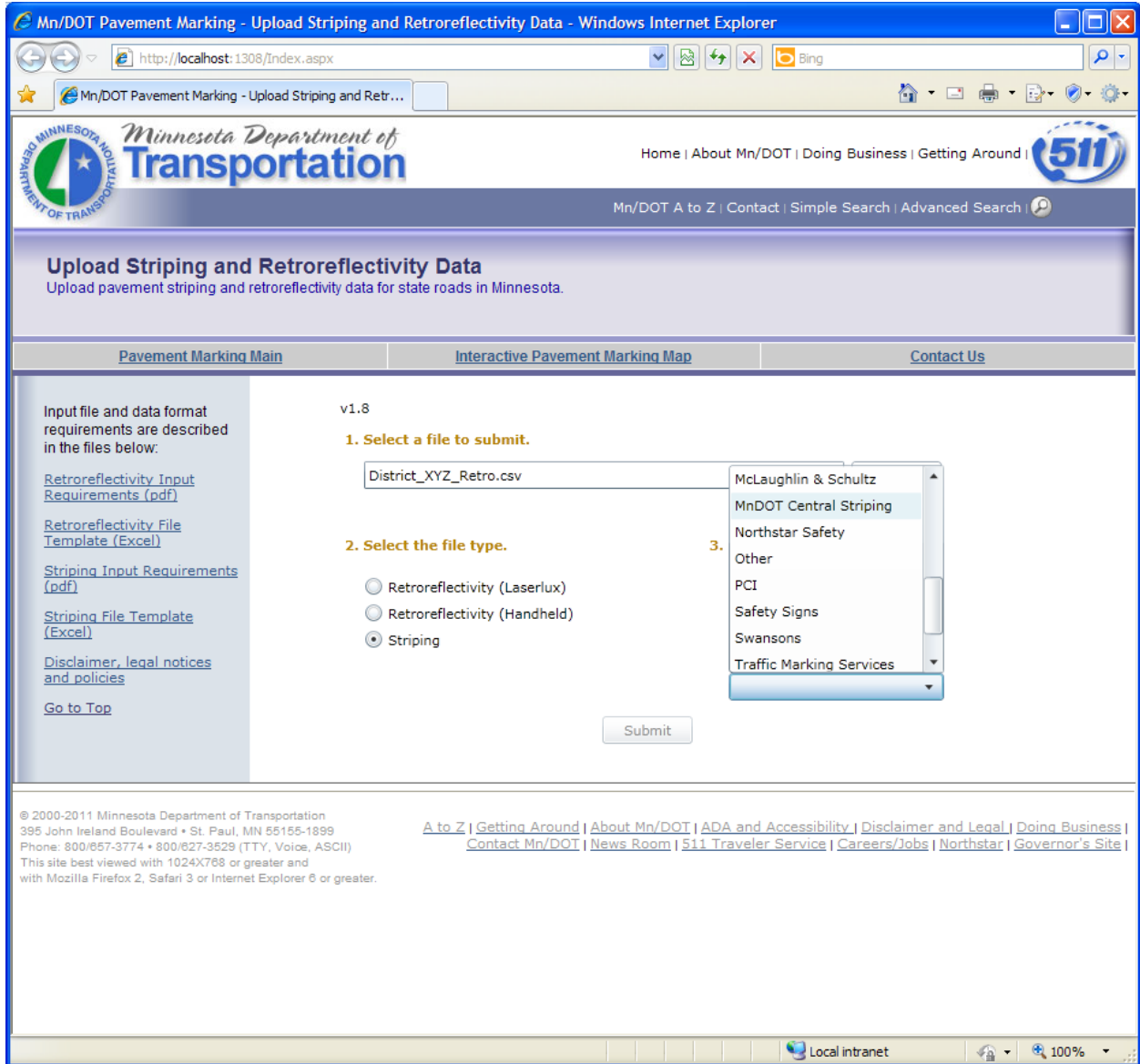

9. When processing begins you will receive a wait screen and if processing has completed successfully a prompt will display.

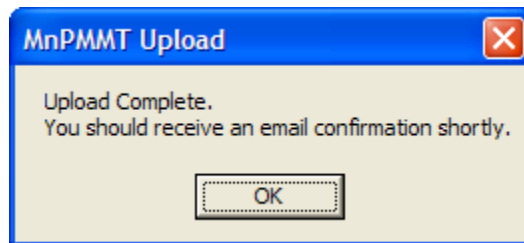

10. The email message you receive will indicate how many records were processed and may have a couple of file attachments indicating record errors that have occurred and a description as to why they occurred.
11. IMPORTANT: The records contained within these attachments are only of records that were indicated as having processing issues. If these records are able to be corrected, only submit these records and not the original data file again.

Minnesota DOT Pavement Marking Management System – Web Application

1. The main web portal for PMMT allows you to enter the interactive web map application.

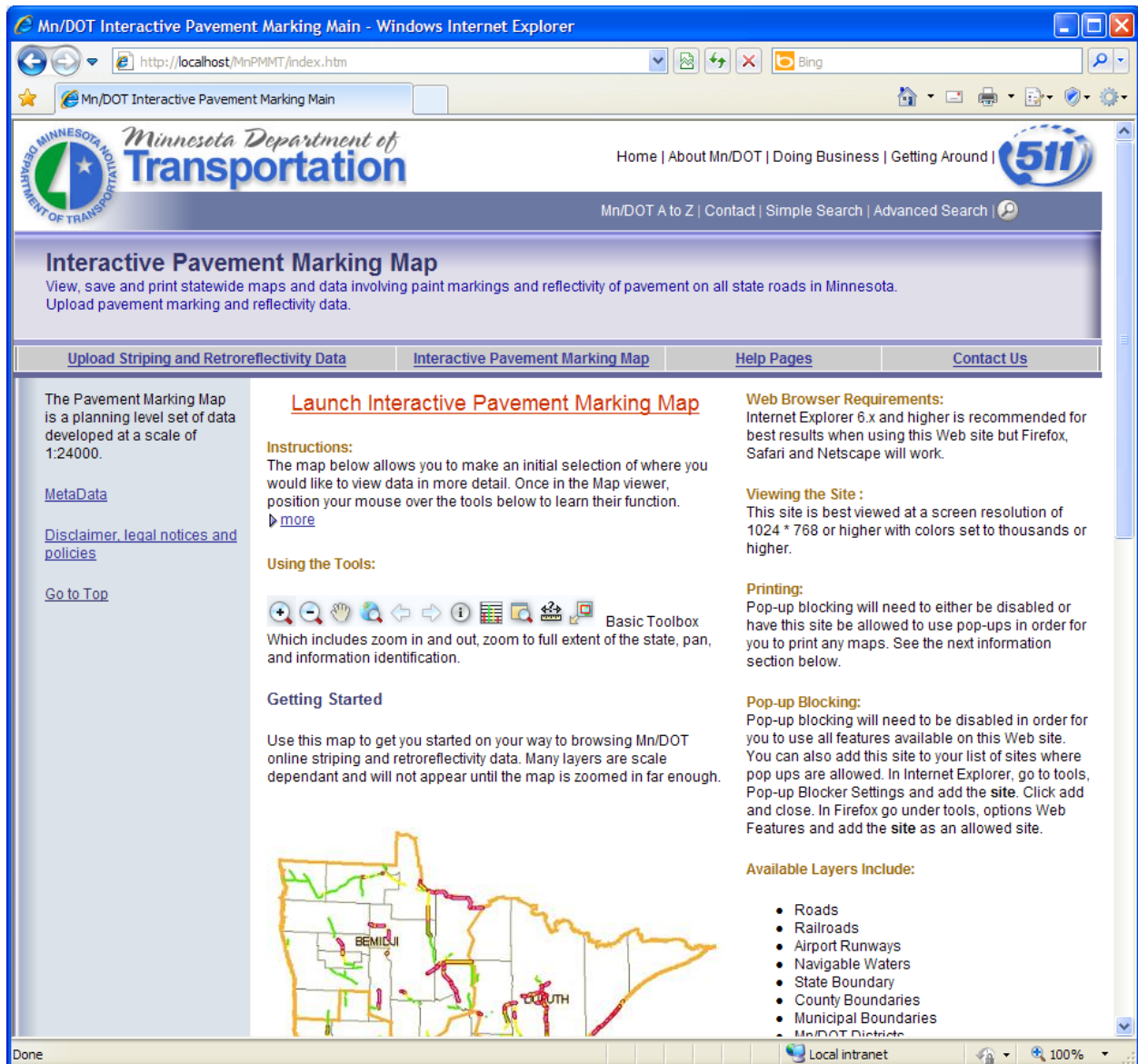

2. Select the Interactive Pavement Marking Map link at the top of the site to enter the web map site.

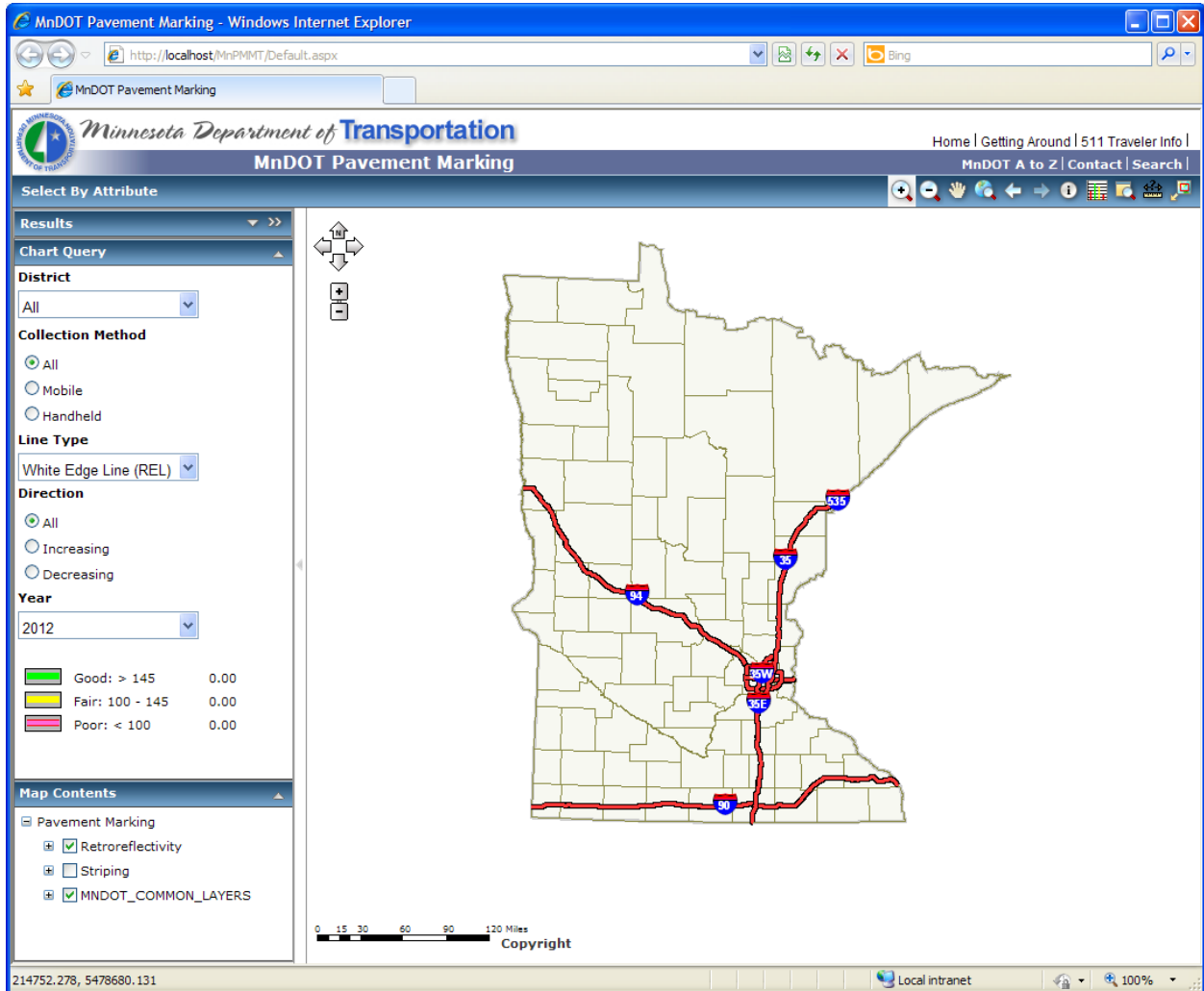

3. On the top right-hand portion of the site the common map controls are available. In order from left to right.
 - a. Zoom In
 - b. Zoom Out
 - c. Pan
 - d. Full Extent
 - e. Back Extent
 - f. Forward Extent
 - g. Map Identify
 - h. Chart (custom tool described at 6)
 - i. Magnifier
 - j. Measure
 - k. Show Overview Map

4. The **Chart Query** pane on the left side of the website allows the user to specify what type of information is shown in the map window. These selections affect the Chart tool output and other query results.

The screenshot displays the MnDOT Pavement Marking website interface. The browser window title is "MnDOT Pavement Marking - Windows Internet Explorer". The address bar shows "http://localhost/MinPMMT/". The page header includes the Minnesota Department of Transportation logo and the text "MnDOT Pavement Marking". The main content area features a map of Minnesota with major highways highlighted in red. On the left side, there is a "Chart Query" pane with the following filters:

- District:** A dropdown menu set to "All".
- Direction:** Radio buttons for "All" (selected), "Increasing", and "Decreasing".
- Year:** A dropdown menu set to "2012".

Below the filters is a legend with three categories:

Green	Good: > 145	0.00
Yellow	Fair: 100 - 145	0.00
Red	Poor: < 100	0.00

The "Map Contents" pane on the left shows the following checked items:

- Pavement Marking
- Retroreflectivity
- Striping
- MNDOT_COMMON_LAYERS

The map includes a scale bar (0 to 112 Miles) and a "Copyright" notice. The browser status bar at the bottom shows "Local intranet" and "100%".

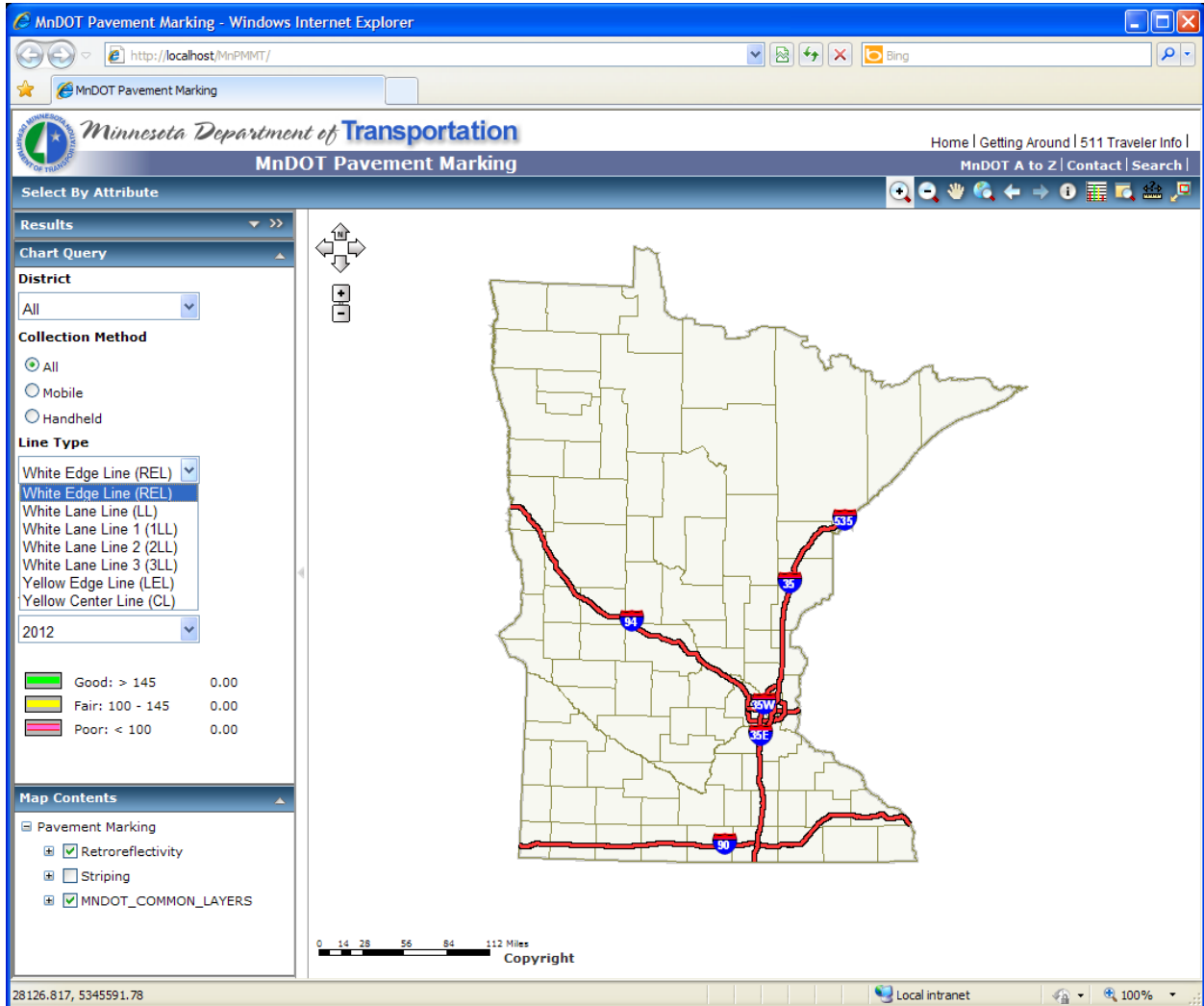

- a. The **District** drop-down list allows the choice of all data or only data within the bounds of the district selected.

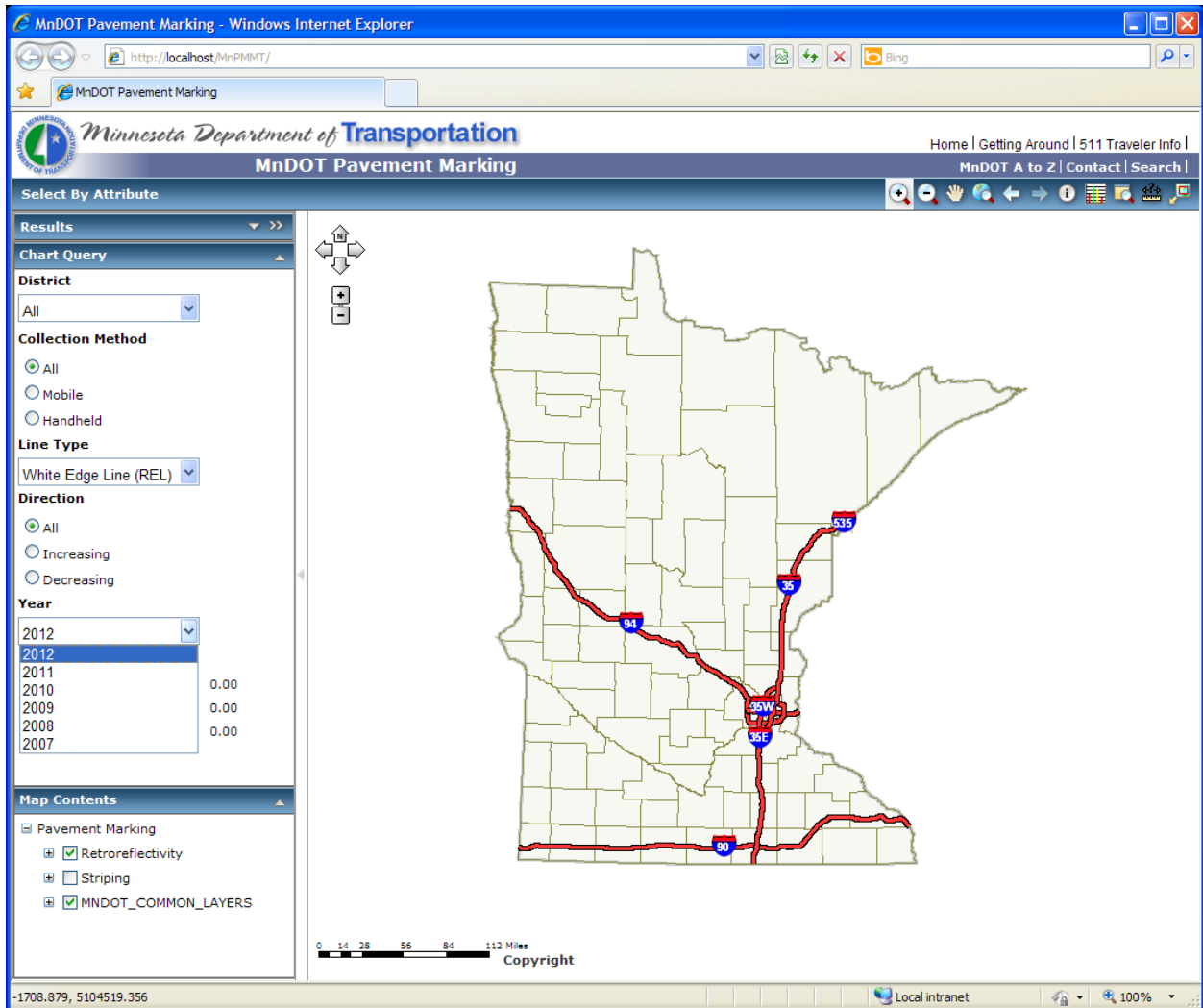

- b. The **Collection Method** radio list allows the choice of all data or only the selected collection method.
- c. The **Line Type** drop-down list allows the choice of a single paint line type to view.



- d. The **Direction** radio list allows the choice of all or only the selected route direction.
- e. The **Year** drop-down list allows the selection of a single year of data to view.
- f. The display below the year drop-down list shows the number of miles currently displayed on the map and the retroreflectivity quality based on the criteria selected.
 - i. The example below shows that 84.93 miles of roadway are within the good range of retroreflectivity readings, 93.16 miles are in the fair range, and 100.97 miles are considered to be poor with a retroreflectivity reading below 100.

	Good: > 145	84.93
	Fair: 100 - 145	93.16
	Poor: < 100	100.97

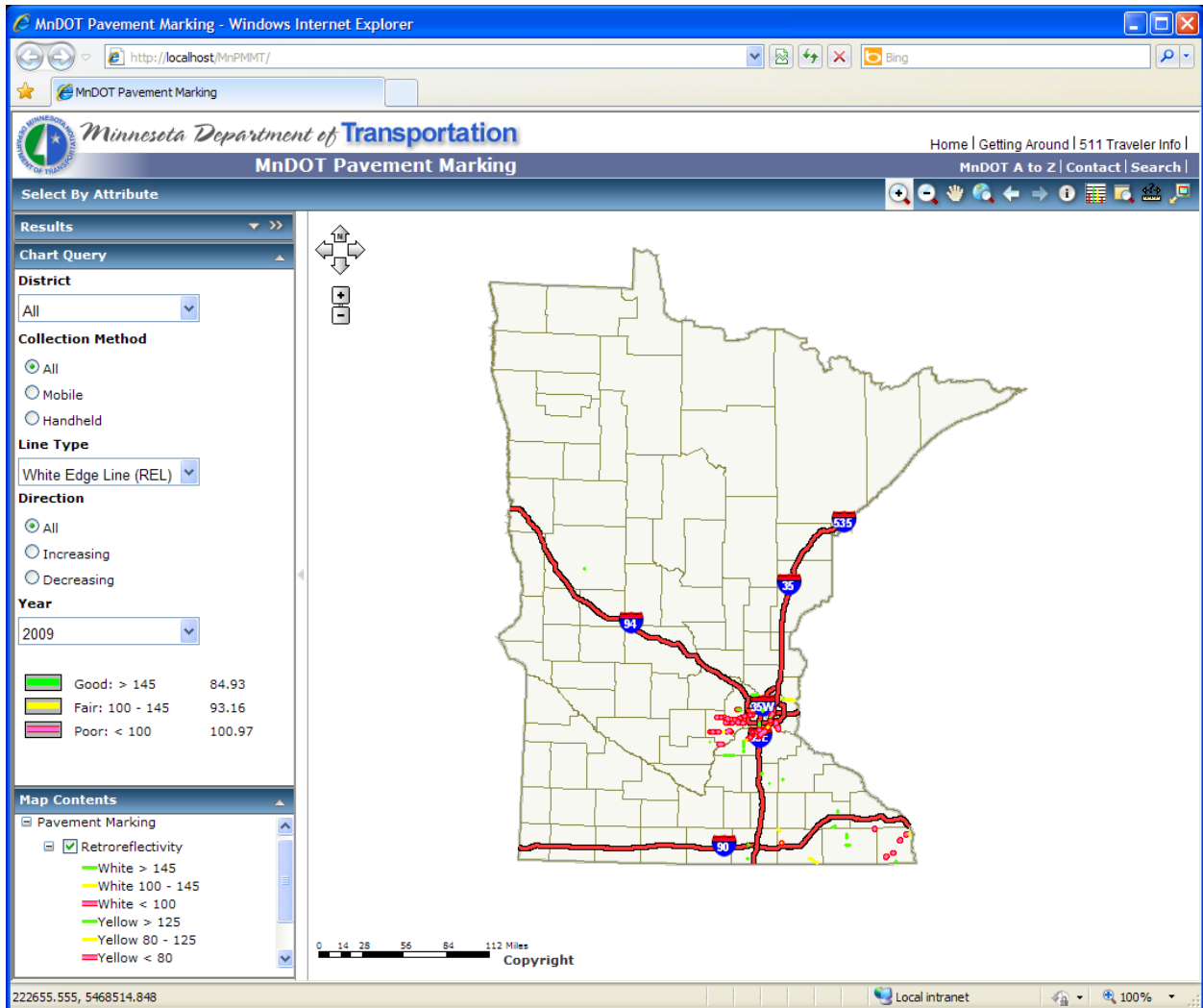

5. The **Map Contents** pane controls the viewable map layers. *Note: Only one Pavement Marking layer (Retroreflectivity or Striping) can be displayed on the map at a time. When either layer is selected the other layer is automatically unselected.*
 - a. Currently selected map layer Retroreflectivity can display retroreflectivity values for both white and yellow line markings.

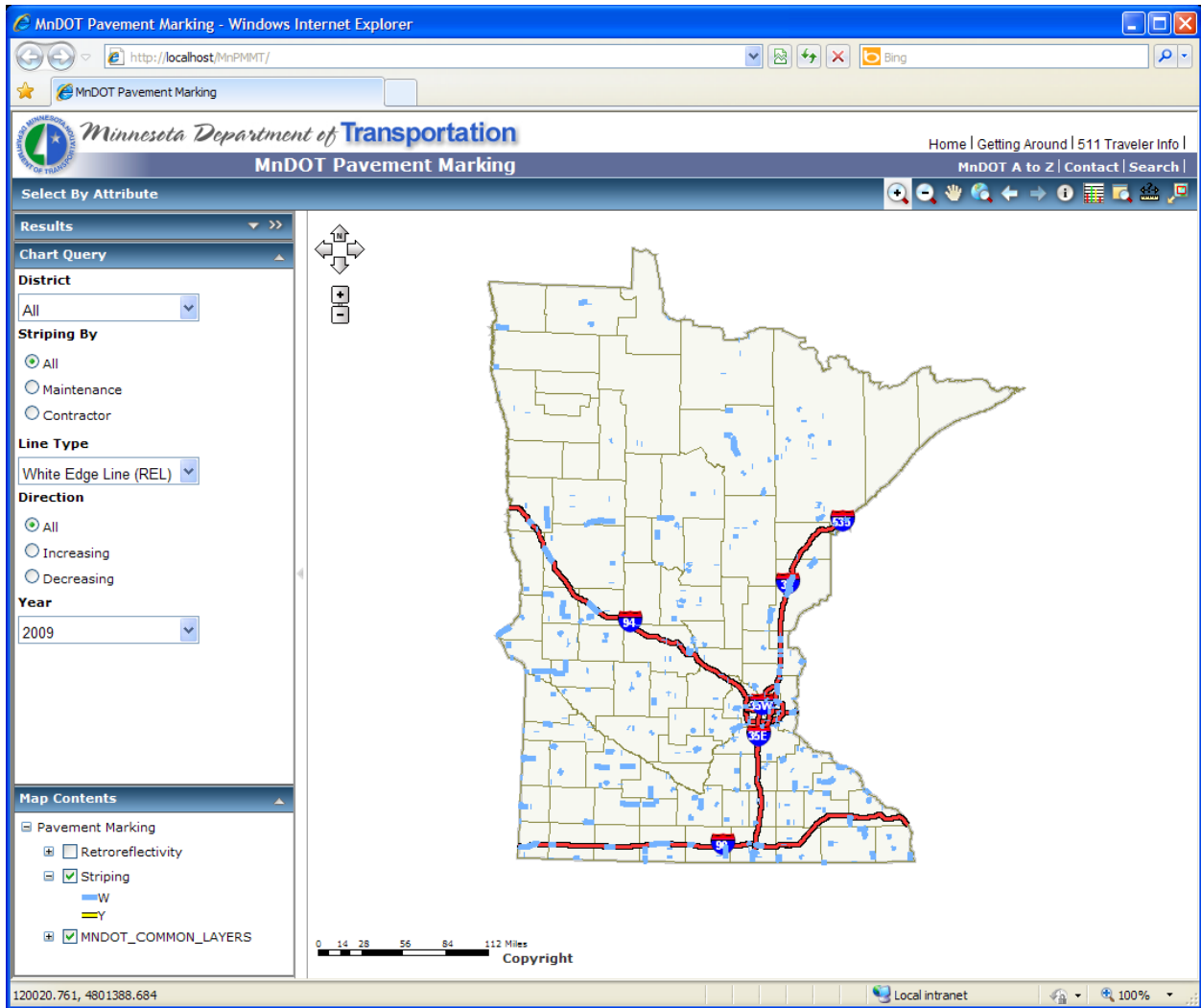

- b. **Map Contents** – the Striping layer shows the line marking types by color.
 - i. Current selection criteria shown; white edge lines (REL), striped by either DOT maintenance crews or by private contractors in all directions of travel for data currently loaded from 2009 in all Minnesota DOT districts.

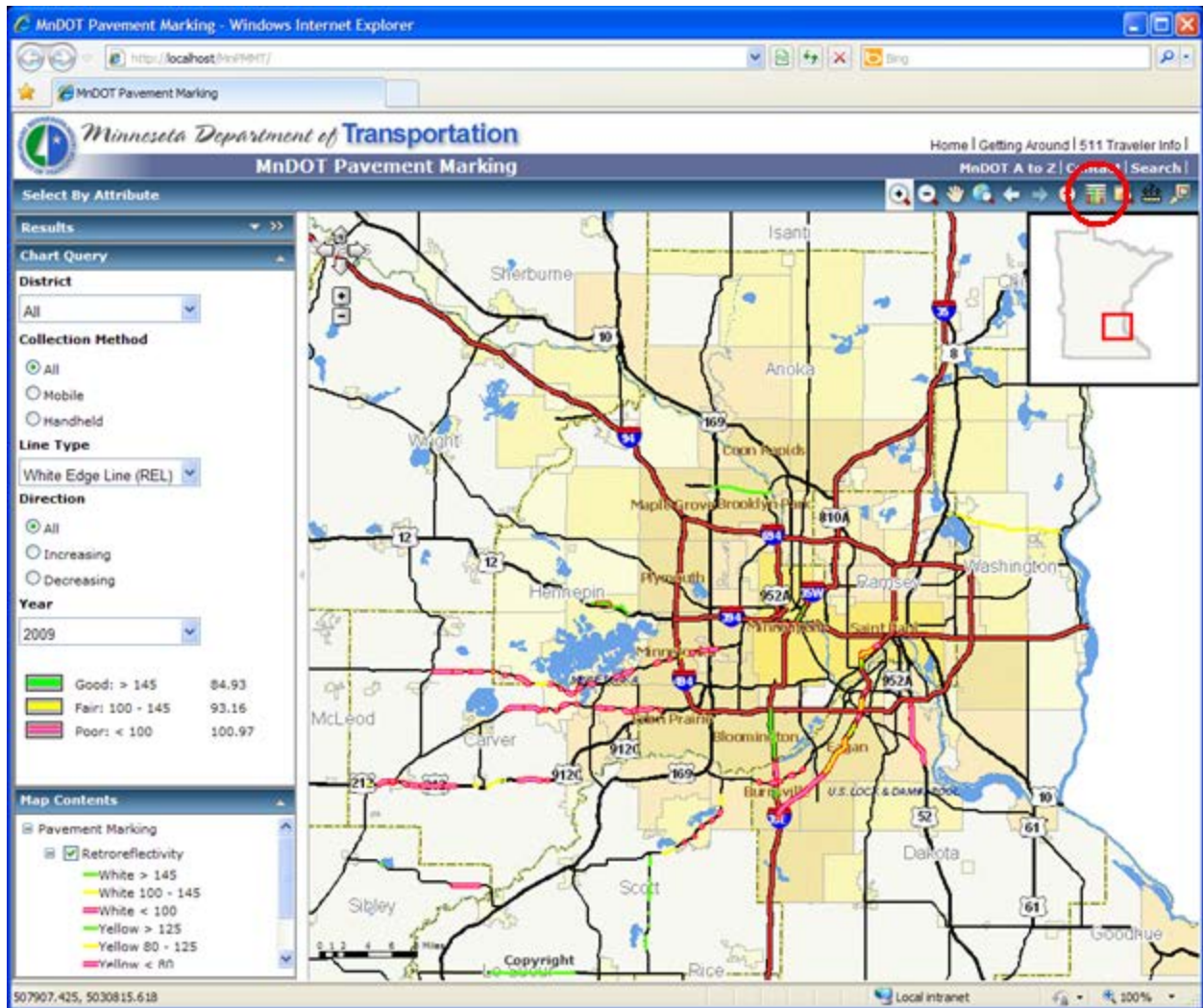

6. Selecting the **Chart** tool from the tool bar (circled in red), the user can select a retroreflectivity line from the map. This generates a bar chart for reflectivity vs. date to visually see how pavement markings are performing over time.
 - a. As an example, a retroreflectivity line was selected on MN5 near reference post 43

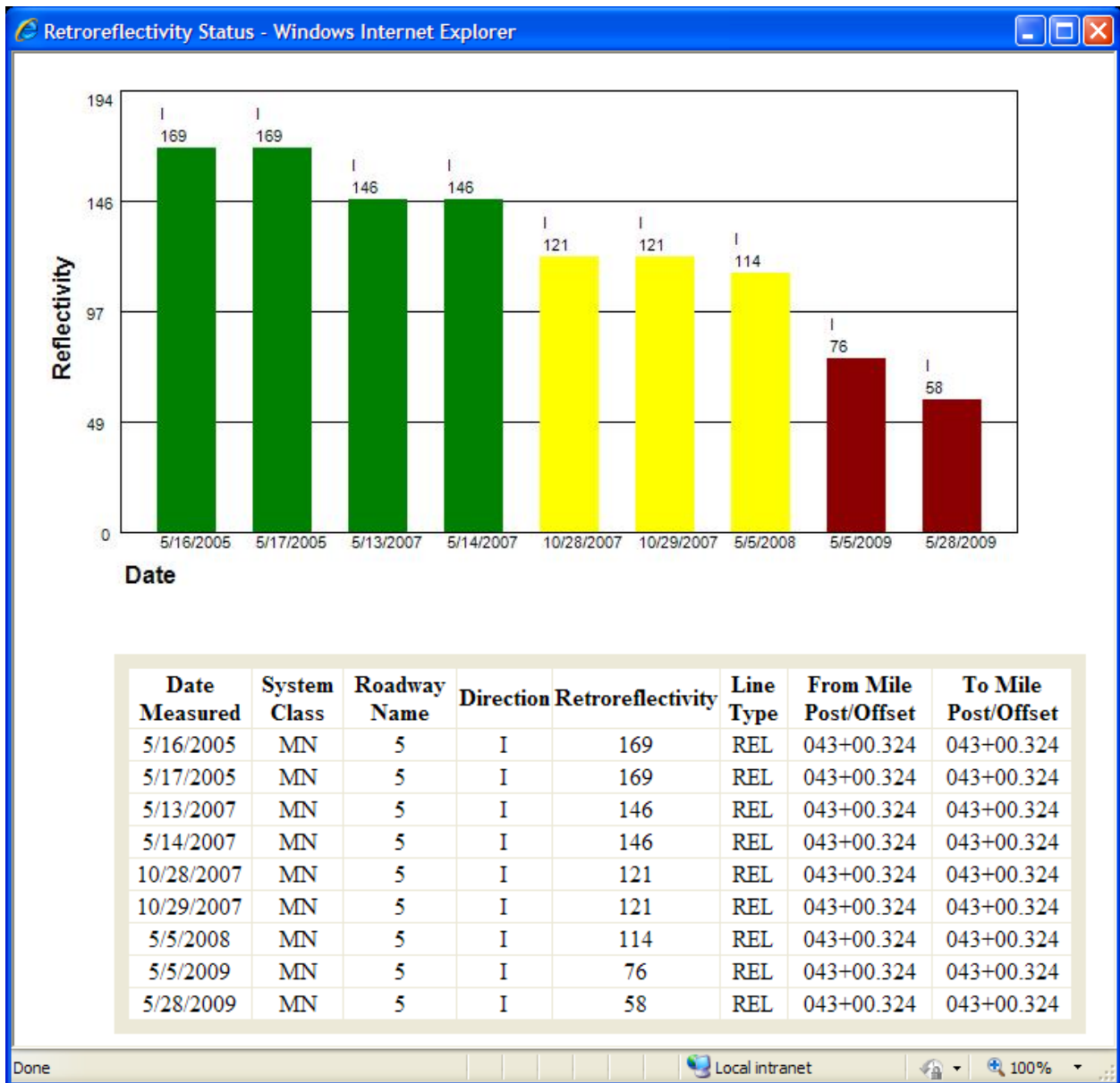

- b. The resulting chart from the **Chart** tool selection made above at MN5 near reference post 43.

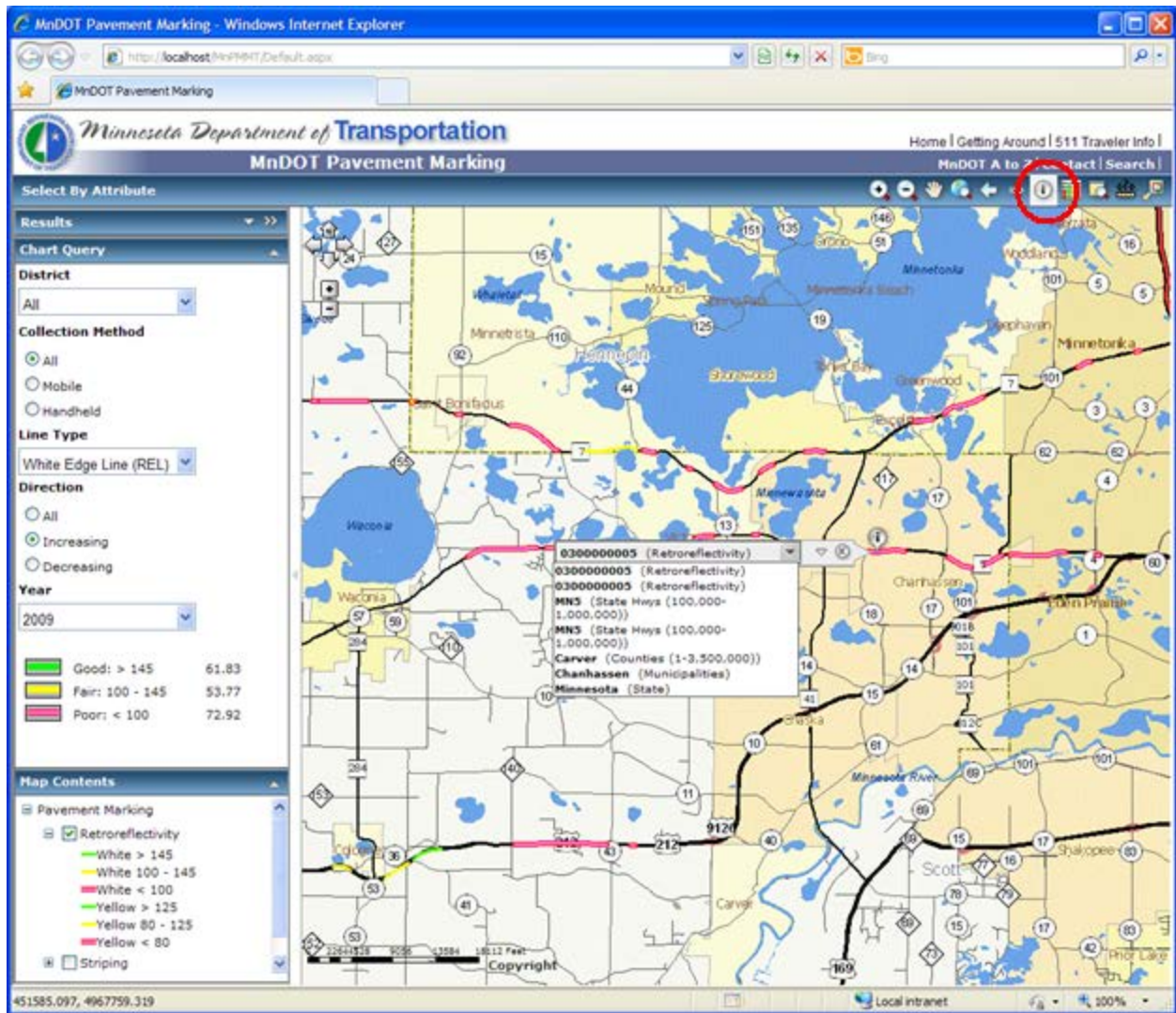

- The **Identity** tool is used to look at specifically selected location information of all available map layers near the point chosen.

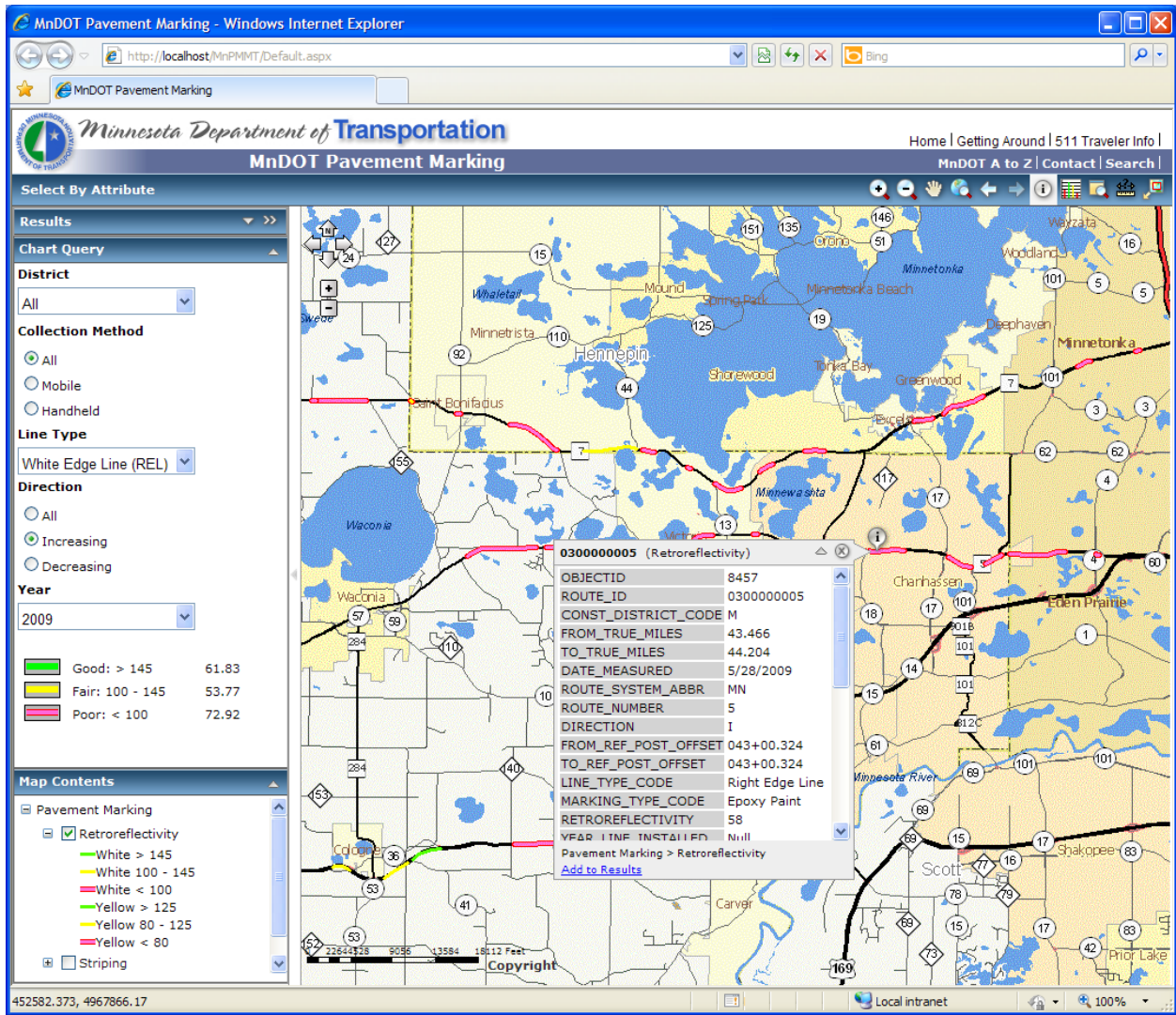

- a. **Identity** tool – after selecting the map layer to view, clicking the down arrow on the popup bar will display the underlying data record for the selected location.

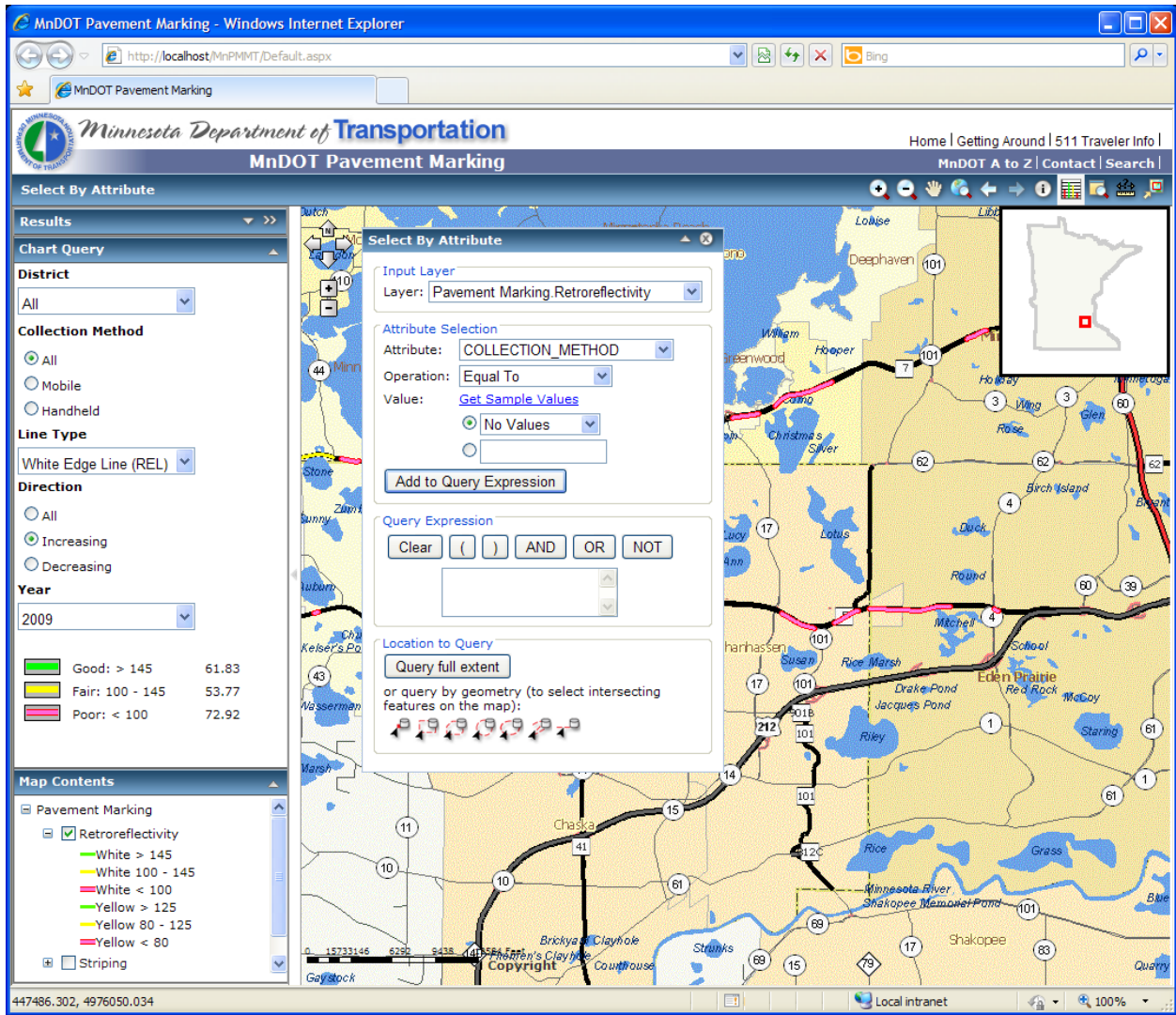

8. Near the top left corner of the website is **Select By Attribute**. This is a querying tool that allows the user to specify attributes and build a Structured Query Language (SQL) like statement to pull records out of the underlying map layers for further analysis.
 - a. Select a *Layer* to be queried, in this case the layer *Retroreflectivity* is chosen.

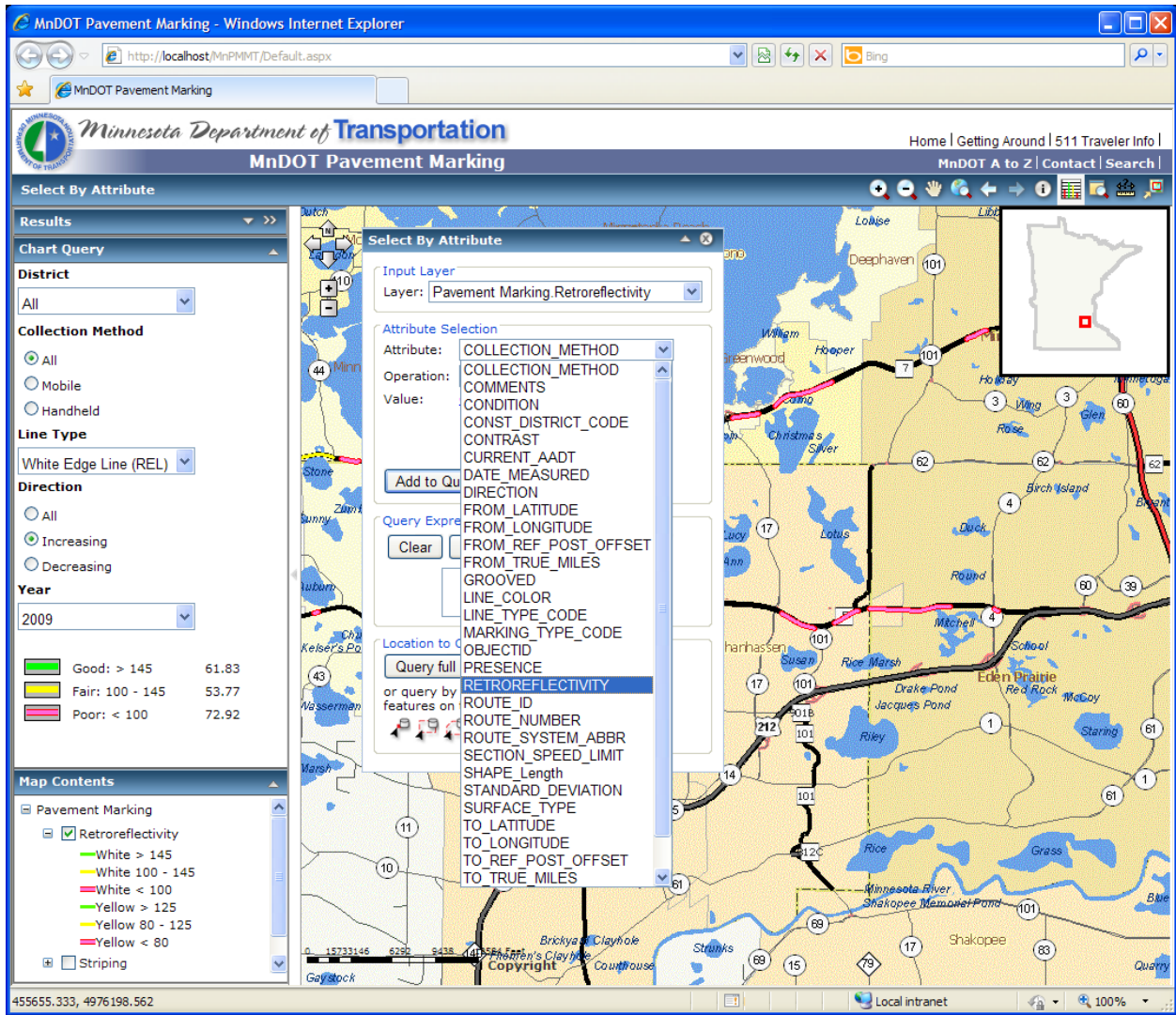

- b. **Select By Attribute** – Continue building a query by selecting an *Attribute* from the drop-down list and an operator from the *Operation* drop-down list.

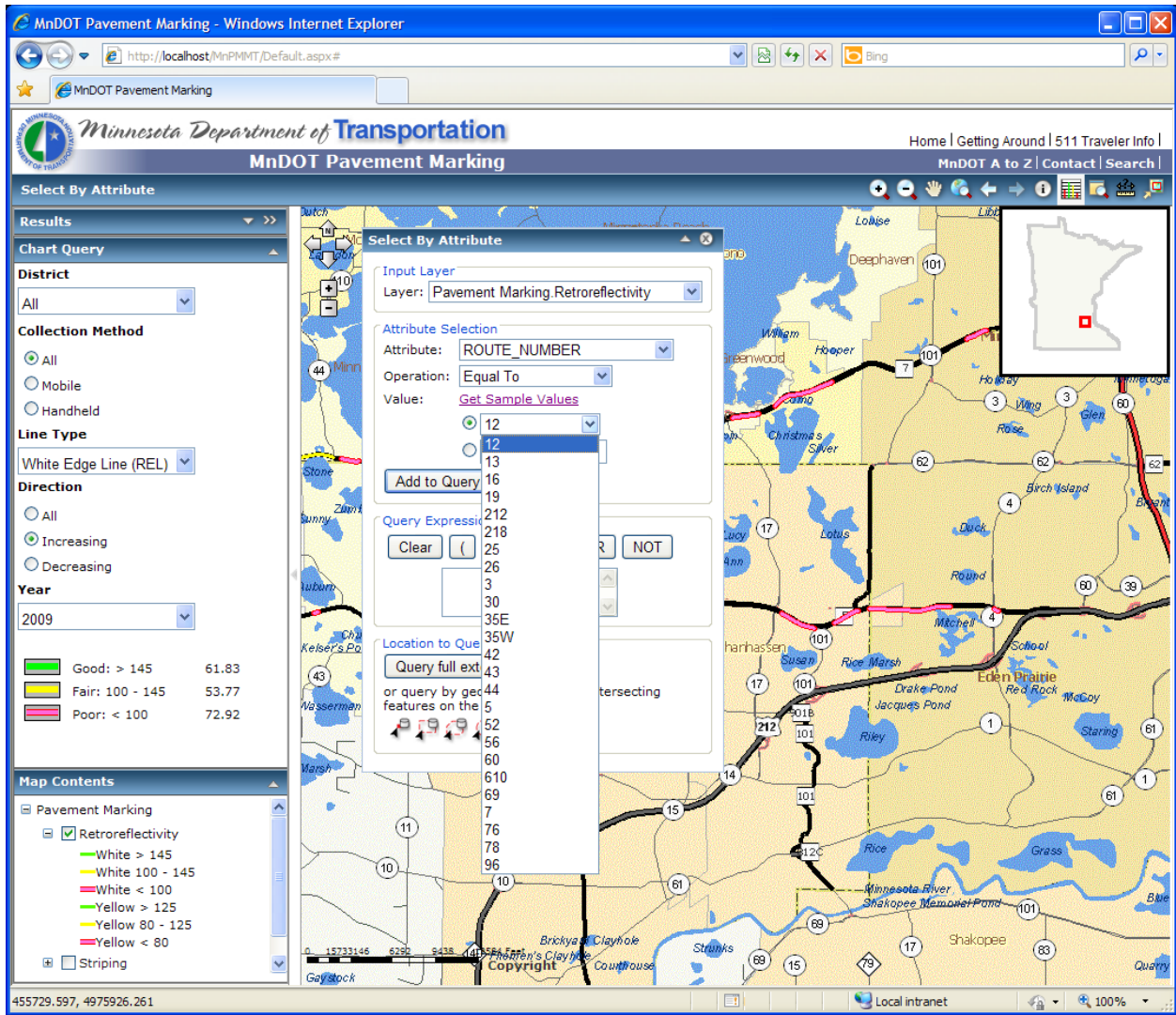

- c. **Select By Attribute** – With an attribute selection made the user has the option to manually input the query Value or use the *Get Sample Values* to populate a drop-down list with values taken from the actual layer data for the selected attribute.

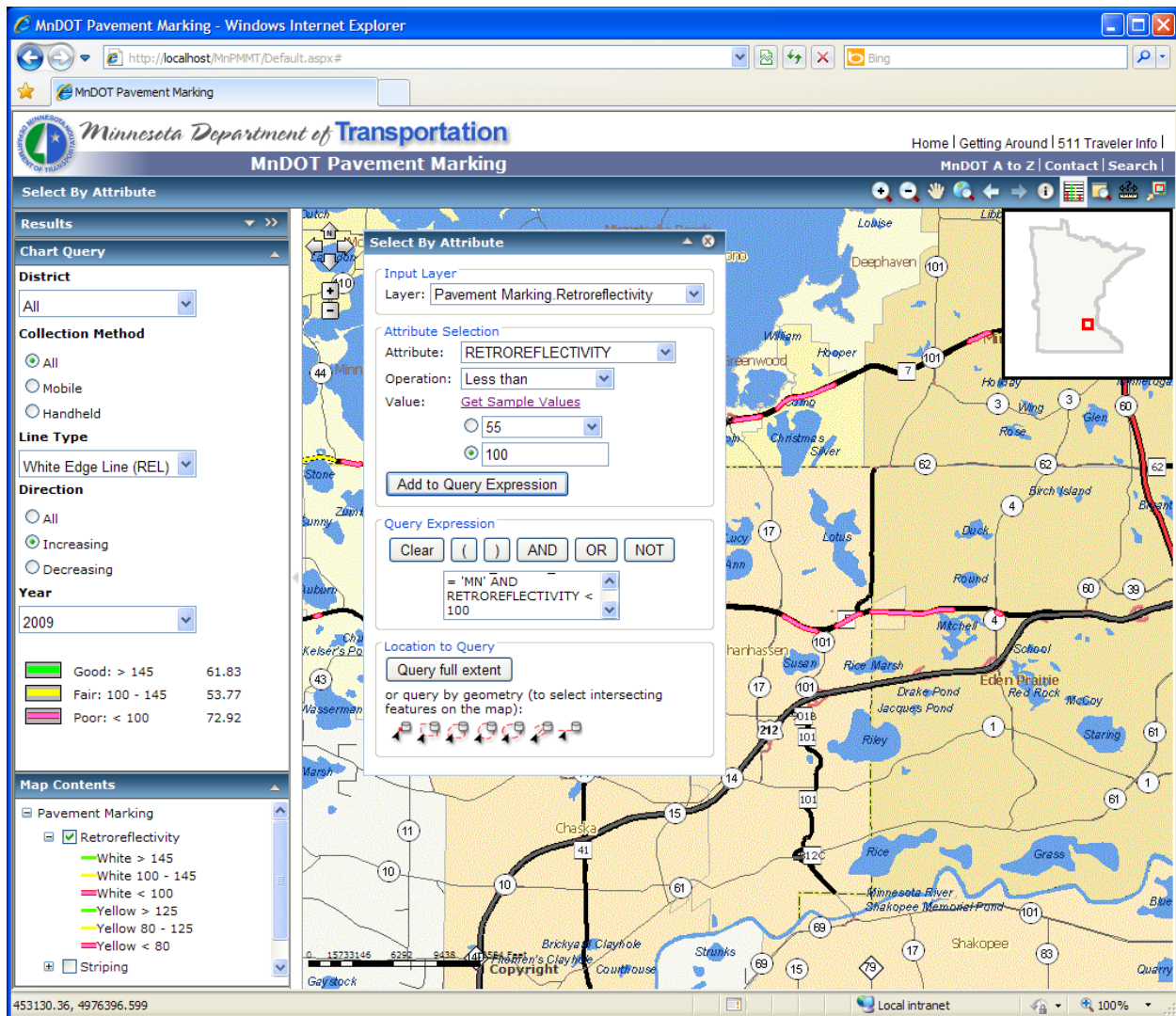

- d. **Select By Attribute** – Once all the Attribute Selections have been made the user clicks on the *Add to Query Expression* button to add the SQL statement to the Query Expression textbox. If additional conditional statements need to be added to the SQL statement the user can select the appropriate button (AND, OR, NOT) to append it to the statement within the textbox. Once the SQL statement has been constructed the user can click the button *Query full extent* to run the SQL query against the selected map layer data.
- i. EXAMPLE: (ROUTE_NUMBER = '5' AND ROUTE_SYSTEM_ABBR = 'MN' AND RETROREFLECTIVITY < 100)
 - ii. NOTE: Criteria selected in the **Chart Query** pane also affect the available data set. Based on the selections in that pane only white edge lines in the increasing lane direction will be selected by the query as well.

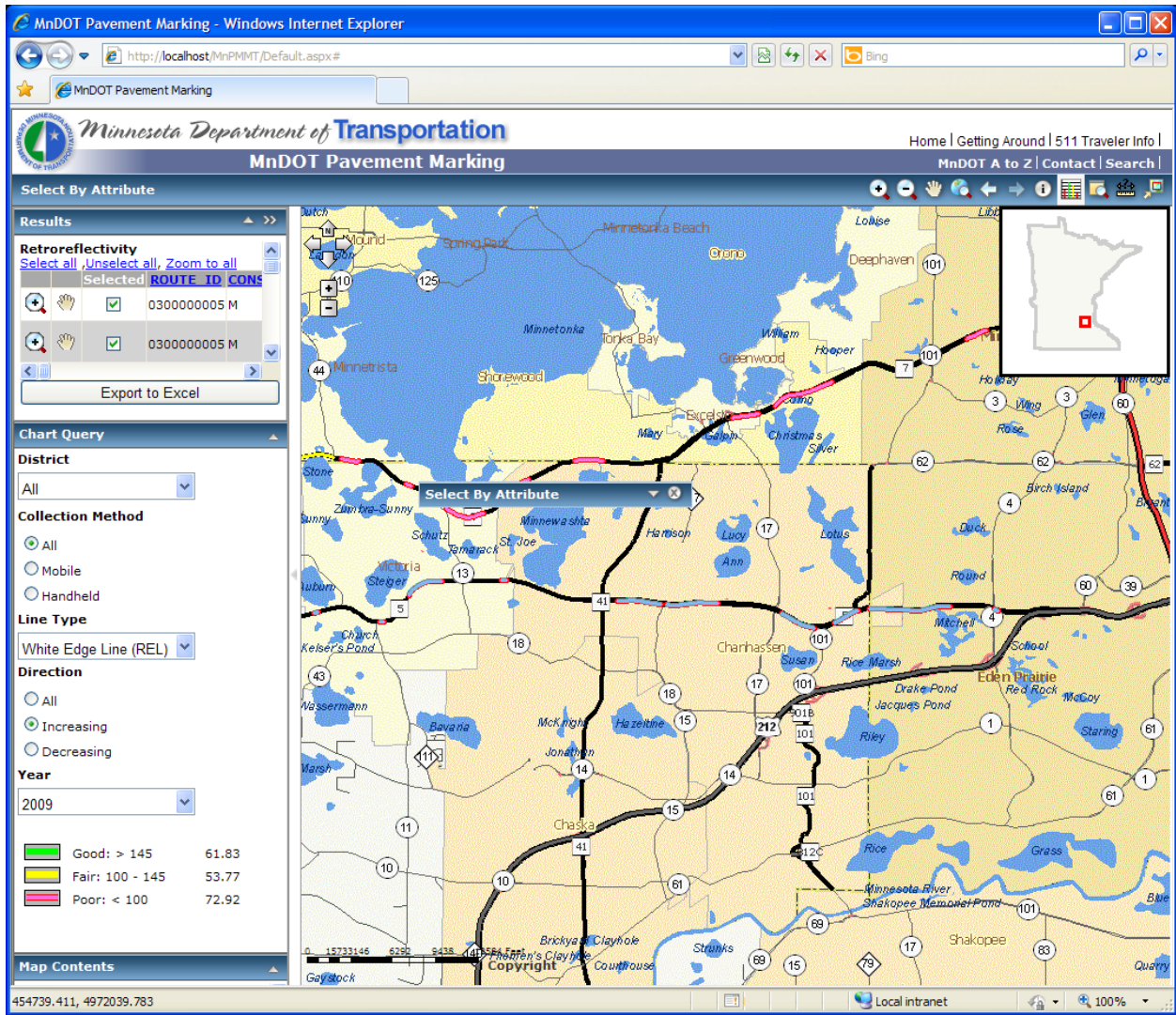

- e. **Select By Attribute** – When the query completes it will populate the **RESULTS** pane on the left side of the webpage.

MnDOT Pavement Marking - Windows Internet Explorer

http://localhost/MnPMNT/Default.aspx#

MnDOT Pavement Marking

Minnesota Department of Transportation
MnDOT Pavement Marking

Home | Getting Around | 511 Traveler Info |
MnDOT A to Z | Contact | Search

Select By Attribute

Chart Query

District: All

Collection Method: All

Line Type: White Edge Line (REL)

Direction: All

Year: 2009

Good: > 145 61.83
Fair: 100 - 145 53.77
Poor: < 100 72.92

Map Contents: Pavement Marking, Retroreflectivity, Stripping, MNDOT_COMMON_LAYERS

Results

ROUTE	SYSTEM	ABBR	ROUTE NUMBER	DIRECTION	FROM REF POST OFFSET	TO REF POST OFFSET	LINE TYPE CODE	MARKING TYPE CODE	RETROREFLE
MN			5	I	039+00.630	039+00.630	REL	E	92
MN			5	I	040+00.960	040+00.960	REL	E	85
MN			5	I	046+00.292	046+00.292	REL	E	85
MN			5	I	047+01.044	047+01.044	REL	E	83
MN			5	I	038+00.992	038+00.992	REL	E	83
MN			5	I	037+00.990	037+00.990	REL	E	79
MN			5	I	036+00.363	036+00.363	REL	E	79
MN			5	I	043+00.324	043+00.324	REL	E	76

Export to Excel

470384.343, 4963895.506

f. **Select By Attribute** – Clicking the double arrow will move the **Results** pane into the main window allowing the user to expand the table view.

Results

ROUTE	SYSTEM	ABBR	ROUTE NUMBER	DIRECTION	FROM REF POST OFFSET	TO REF POST OFFSET	LINE TYPE CODE	MARKING TYPE CODE	RETROREFLE
MN			5	I	039+00.630	039+00.630	REL	E	92
MN			5	I	040+00.960	040+00.960	REL	E	85
MN			5	I	046+00.292	046+00.292	REL	E	85
MN			5	I	047+01.044	047+01.044	REL	E	83
MN			5	I	038+00.992	038+00.992	REL	E	83
MN			5	I	037+00.990	037+00.990	REL	E	79
MN			5	I	036+00.363	036+00.363	REL	E	79
MN			5	I	043+00.324	043+00.324	REL	E	76

Export to Excel

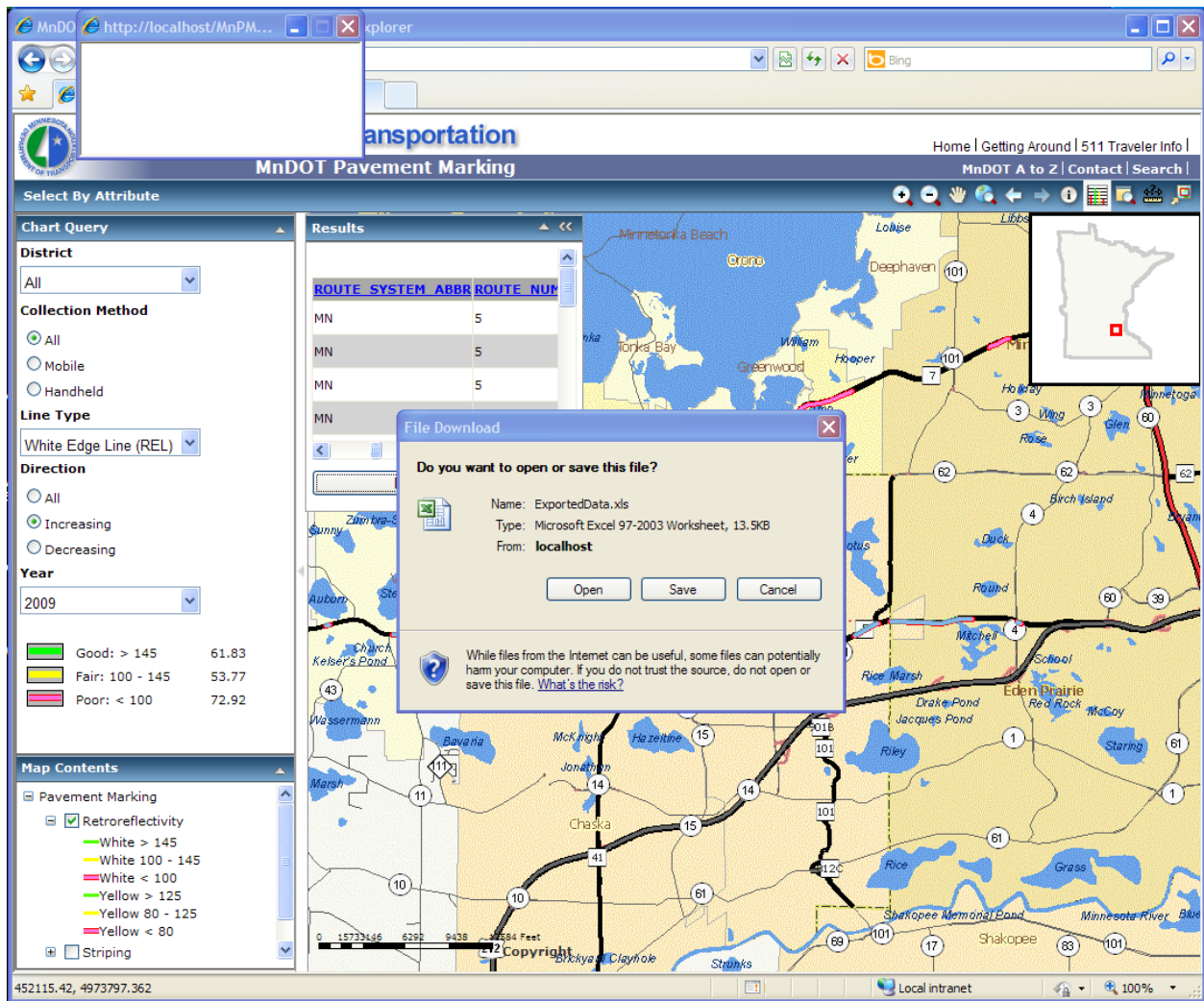

- g. **Results** – The results can be viewed or saved to an Excel file by clicking on the *Export to Excel* button.

ExportedData[1].xls - Microsoft Excel

File Home Insert Page Layout Formulas Data Review View Developer Add-Ins Menus Acrobat Team

Calibri 11 A A

General

Clipboard Font Alignment Number Styles

Wrap Text

Conditional Formatting as Table Styles

Format Cell Styles

Insert Delete Format Cells

Sort & Filter Select Editing

A1 OBJECTID

	A	B	C	D	E	F	G	H	I	J	K	L	M	N	
1	OBJECTID	ROUTE_ID	CON	FROM TRUE	TO TRUE MILES	DATE MEASURED	ROUTE	ROUT	DIRECTION	FROM_REF_P	TO_REF_POST	LINE_TYP	MAR	RETROREFLECTIVITY	YE
2	8659	300000005	M	39.778	40.285	5/5/2009 0:00	MN	S	I	039+00.630	039+00.630	REL	E		92
3	7814	300000005	M	41.102	41.182	5/5/2009 0:00	MN	S	I	040+00.960	040+00.960	REL	E		85
4	9654	300000005	M	46.44	47.598	5/5/2009 0:00	MN	S	I	046+00.292	046+00.292	REL	E		85
5	8791	300000005	M	48.193	48.263	5/5/2009 0:00	MN	S	I	047+01.044	047+01.044	REL	E		83
6	9824	300000005	M	39.147	39.243	5/5/2009 0:00	MN	S	I	038+00.992	038+00.992	REL	E		83
7	5836	300000005	M	38.134	38.195	5/5/2009 0:00	MN	S	I	037+00.990	037+00.990	REL	E		79
8	8850	300000005	M	36.505	37.654	5/5/2009 0:00	MN	S	I	036+00.363	036+00.363	REL	E		79
9	5837	300000005	M	43.466	44.204	5/5/2009 0:00	MN	S	I	043+00.324	043+00.324	REL	E		76
10	9519	300000005	M	45.079	45.62	5/5/2009 0:00	MN	S	I	044+00.955	044+00.955	REL	E		73
11	6686	300000005	M	42.633	43.334	5/5/2009 0:00	MN	S	I	042+00.502	042+00.502	REL	E		72
12	7060	300000005	M	34.925	36.336	5/5/2009 0:00	MN	S	I	034+00.874	034+00.874	REL	E		68
13	5272	300000005	M	46.44	47.598	5/28/2009 0:00	MN	S	I	046+00.292	046+00.292	REL	E		66
14	8660	300000005	M	45.876	46.28	5/5/2009 0:00	MN	S	I	045+00.742	045+00.742	REL	E		64
15	9336	300000005	M	48.193	48.263	5/28/2009 0:00	MN	S	I	047+01.044	047+01.044	REL	E		63
16	9599	300000005	M	42.633	43.334	5/28/2009 0:00	MN	S	I	042+00.502	042+00.502	REL	E		61
17	7909	300000005	M	34.925	36.336	5/5/2009 0:00	MN	S	I	034+00.874	034+00.874	REL	E		60
18	8457	300000005	M	43.466	44.204	5/28/2009 0:00	MN	S	I	043+00.324	043+00.324	REL	E		58
19	6472	300000005	M	45.876	46.28	5/28/2009 0:00	MN	S	I	045+00.742	045+00.742	REL	E		57
20	7619	300000005	M	45.079	45.62	5/28/2009 0:00	MN	S	I	044+00.955	044+00.955	REL	E		55
21															
22															
23															
24															
25															
26															
27															
28															

ExportedData 1

Ready

100%

h. **Results** – The query results presented as an exported Excel file.

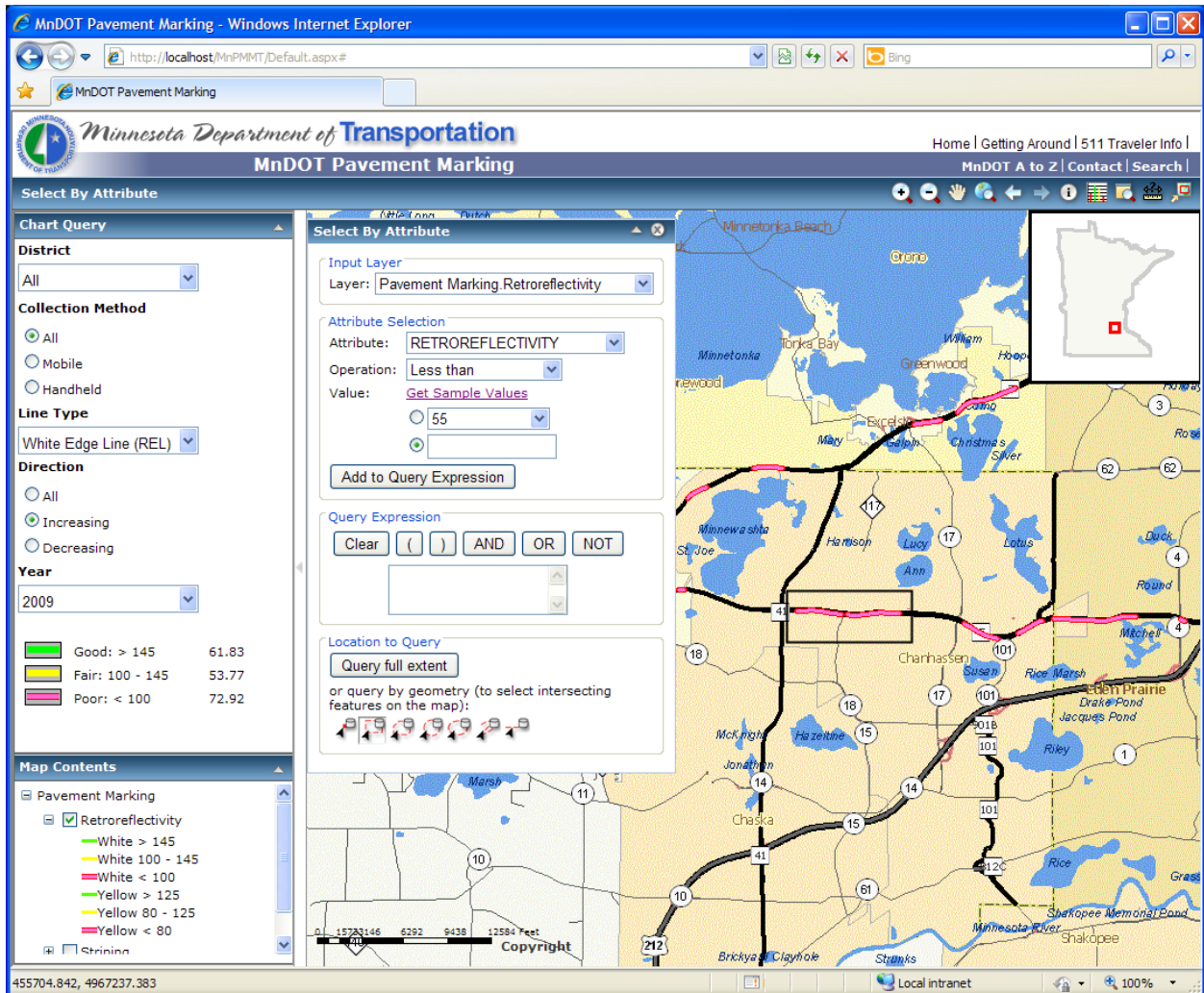

9. **Select By Attribute** – Query results can also be generated using the geometry tools located at the bottom of the **Select By Attribute** window.
 - a. Shown above the rectangle geometry selection tool is selected and a box is drawn by the user around an area of interest.

Chart Query

District: All

Collection Method: All

Line Type: White Edge Line (REL)

Direction: All

Year: 2009

Good: > 145	61.83
Fair: 100 - 145	53.77
Poor: < 100	72.92

Map Contents

- Retroreflectivity
 - White > 145
 - White 100 - 145
 - White < 100
 - Yellow > 125
 - Yellow 80 - 125
 - Yellow < 80
- Striping

Results

DATE MEASURED	ROUTE	SYSTEM	ABBR	ROUTE NUMBER	DIRECTION	FROM	REF	POST	OFFSE
5/28/2009 12:00:00 AM	MN			5	I	043+00.324			
5/5/2009 12:00:00 AM	MN			5	I	043+00.324			
5/5/2009 12:00:00 AM	MN			5	I	042+00.502			
5/28/2009 12:00:00 AM	MN			5	I	042+00.502			

Export to Excel

- b. **Select By Attribute** – The selection is highlighted and the data resulting from the selection is populated into the **Results** pane and can be viewed or exported in the same manner as doing a SQL based query.

Task 6A Investigate Automation of Striping Data

Skip Line Format - The research team visited the Metro paint crew during Phase I of the project and collected a sample of skip line striping data from the 2006 and 2007 seasons. Since some of the data included GPS readings (latitude, longitude) the data were plotted for review as shown in Figure 3.



© Google

Figure 3. Example Plot from Skip Line Controller Data (Plotted by Truck Speed)

New data were obtained from Central Striping from the Metro truck equipped with the Skipline controller. The next three figures show some of the results. The Skipline controller keeps data on quantities (paint and beads), location (by latitude and longitude if activated), type of line by color, environmental data (road temperature, ambient temperature, and humidity), and other data. Currently, the program does not support all the striping data information required by the PMMT, but with some minor modifications this data can be provided by the operators and saved into the database.

Metro district Skipline data for where the truck painted. As the map shows, the Metro District truck applied paint in the NE, SW, and metro areas. Figure 5 provides a magnification of paint activities and Figure 6 shows locations where the paint was applied at travel speeds over 15 mph.

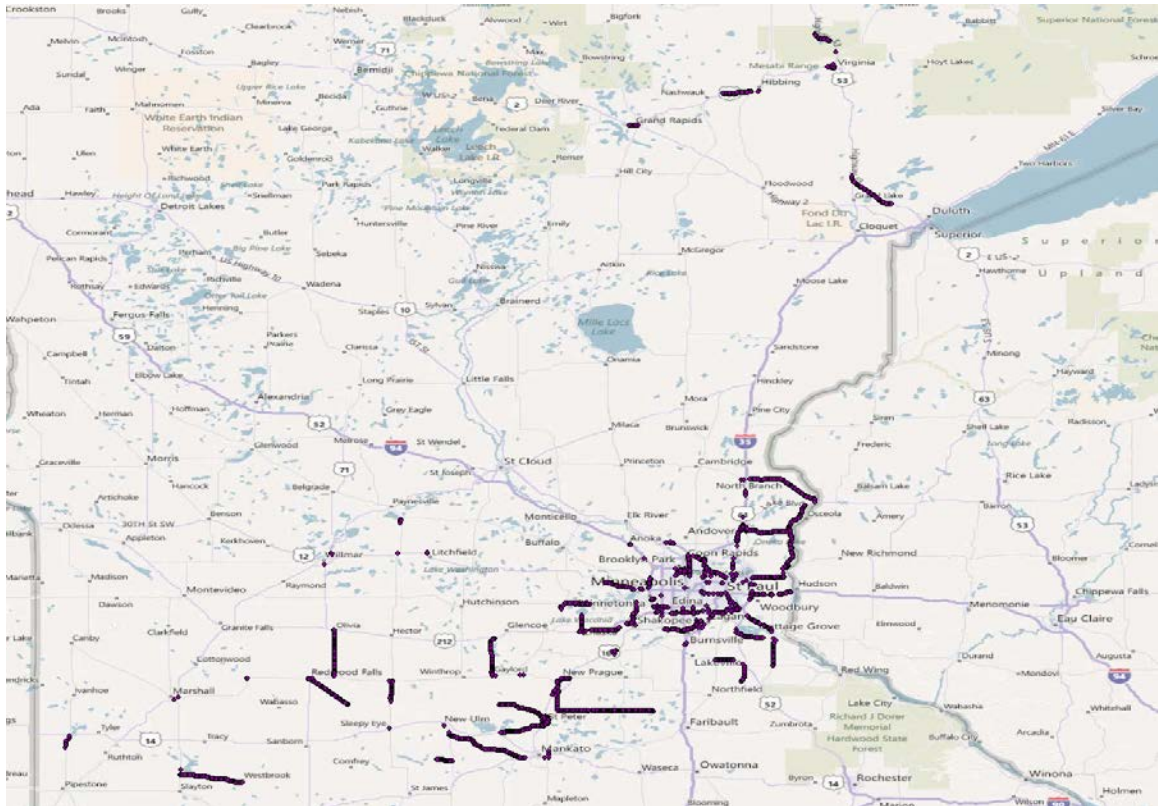

Figure 4. Paint Coverage Areas

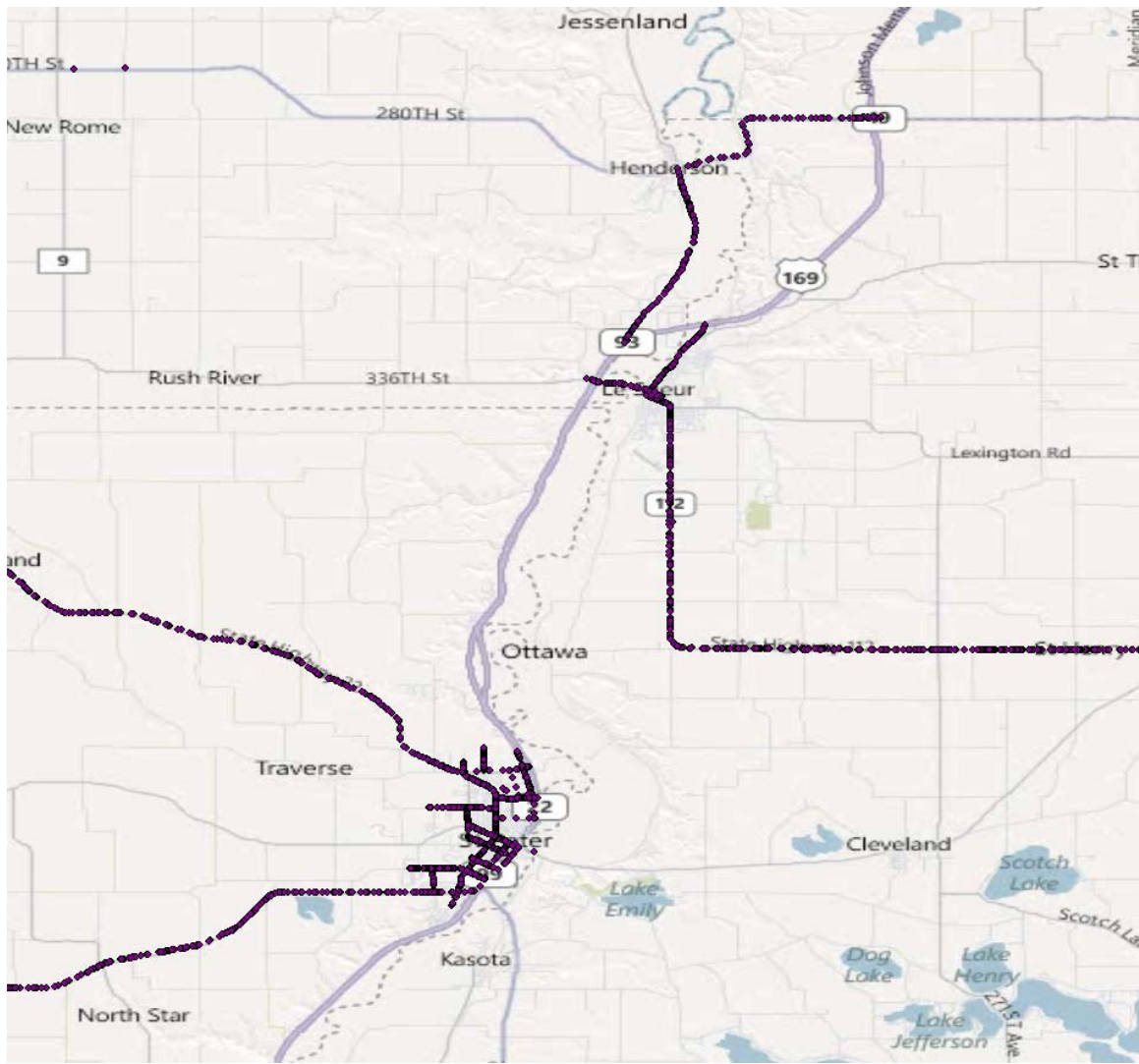

Figure 5. Magnified Areas for Paint

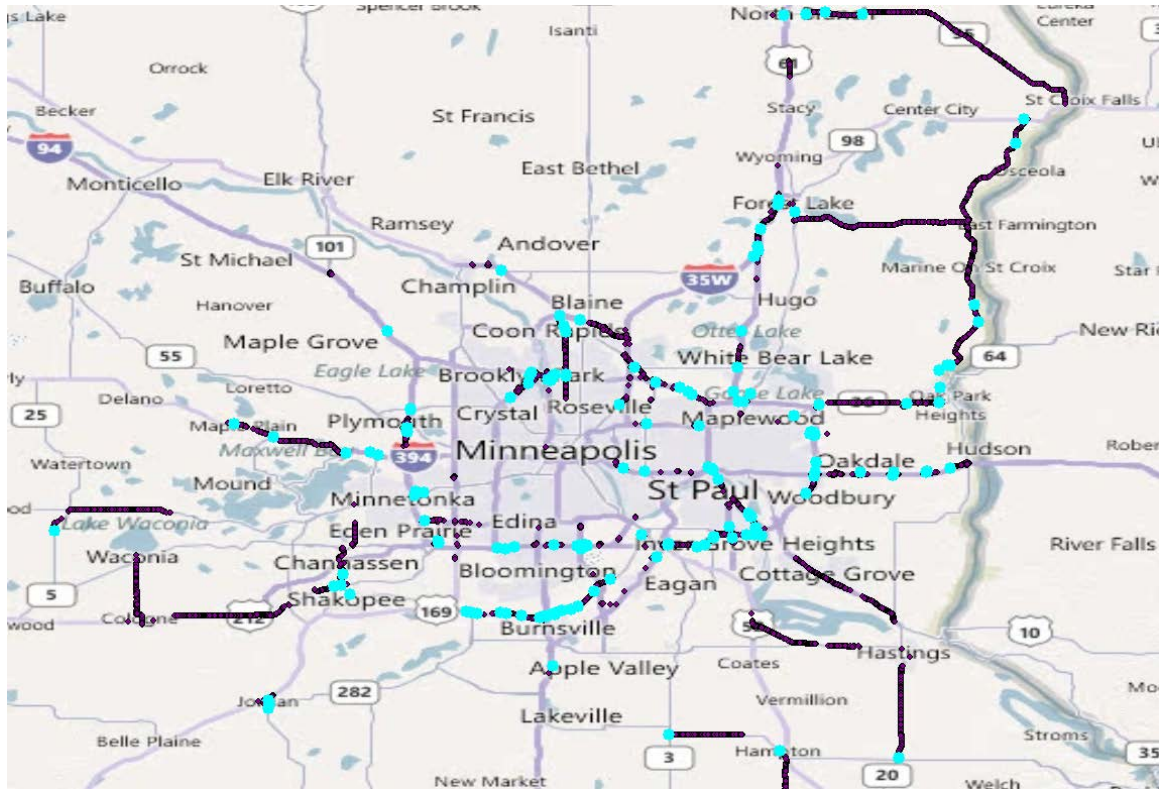

Figure 6. Areas with Application Speed over 15 mph

Based on the results from this investigation, MnDOT’s Office of Traffic, Safety and Technology developed specifications for a Data Logging System (DLS) which establishes the data requirements and formats to transfer applied striping data from data logging devices into MnDOT’s PMMT database in an automated fashion. This specification is required to be used by all MnDOT striping contractors. MnDOT is also planning to equip their trucks over time with the same system. The specifications are included within Appendix B.

Task 7 District Training

Computer based training on the use of the PMMT tool and handheld retroreflectometer equipment was provided by the research team to relevant MnDOT staff at a number of locations across the state, including:

- November 22 – D6 and D7 in Rochester
- November 23 – D1 in Duluth
- November 29 – Metro District and CO at Arden Hills – AM & PM sessions (2 sessions)
- December 7 – Districts 3 and 8 in St Cloud
- December 8 – Districts 2 and 4 in Detroit Lakes

There were between 10 and 14 people in each session (not including CO Traffic or CTRE staff). The comments and feedback were very positive and MnDOT (Mitch Bartelt) kept track of some of the comments and requests for changes. Suggestions that were outside the current scope were discussed by CO Traffic.

The training agenda included the following:

1. Introductions and project background
2. How to collect manual retroreflectivity data? (data collection protocols)
4. How to submit data?
5. Pavement Marking Management Tool (PMMT) operations
6. Handheld LTL-X demonstration and hands-on training
7. Questions and answers

Chapter 3 Conclusions

The research team, in cooperation with MnDOT staff, developed and implemented a web-based GIS tool to help the department to manage pavement marking retroreflectivity to ensure better service for the users. Managing pavement marking visibility has the potential to reduce MnDOT costs, improve pavement marking performance through selecting better materials, and in return provide a more efficient and safe driving experience for the traveling public.

Implementation of the PMMT begins with data, more specifically, pavement marking retroreflectivity and striping data which is incorporated into an ORACLE database. Retroreflectivity provides a measure of the pavement markings visibility under dark conditions on unlighted roadways. The striping data provides information relative to when, where, and how each roadway was painted which supports an analysis of performance over time. Since both MnDOT staff and their Contractors measure retroreflectivity and install markings on MnDOT roadways, implementation of the PMMT included simplifying the process of collecting and submitting data, storing these data, and in providing staff access to the data to turn it into useful information for analysis.

Now that the PMMT is fully implemented, the MnDOT can look into further enhancement of the tool by adding one or more of the following functionalities. Some of those options were suggested by staff during the district training that took place during the project.

- Project planning tool: This will allow the districts to build their paint program (location, materials, lines, quantities, and cost) utilizing the existing information in the tool. A GIS map with detailed information will be created to allow Central Painting to identify the required work and schedule the crews to implement.
- Data mining: This will help MnDOT staff (Central office or districts) to mine the PMMT data to look at pavement marking performance by material, line type, installation type (grooved vs. surface applied) on a state-wide basis or by region.
- Enhance the data: This requires the additional of more information to the PMMT to enhance its analytical capabilities. Information such as winter weather maintenance operations, pavement type and condition, traffic to help develop better pavement marking selection tools and performance metrics.

Appendix A – PMMT Data Process/Flow Chart

Raw Data Upload Process

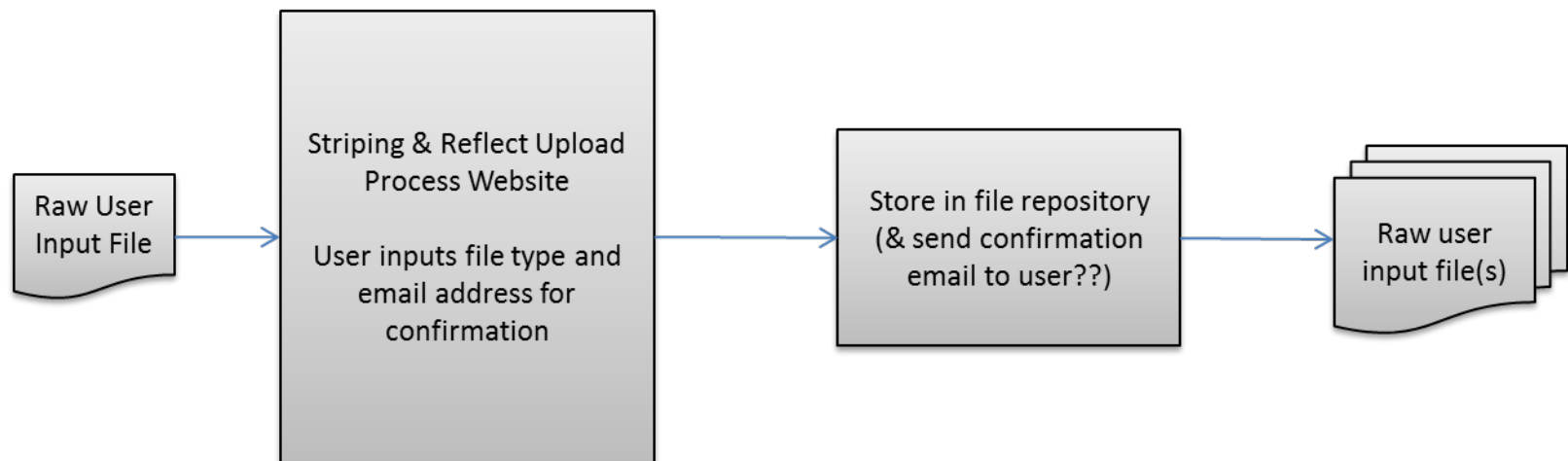

Raw Data Header Requirements

*All field headers indicated are required in file

REFLECT Data

DATE_MEASURED (Data Required)
ROADWAY_NAME (Data Required)
DIRECTION (I or D) (Data Required)
FROM_REF_POST_OFFSET (Data Required, if LATITUDE/LONGITUDE values don't exist)
TO_REF_POST_OFFSET (Data Required, if LATITUDE/LONGITUDE values don't exist)
LINE_TYPE_CODE (Data Required)
RETROREFLECTIVITY (Data Required)
GROOVED (Data Optional)
COMMENTS (Data Optional)
SURFACE_TYPE (Data Optional)
FROM_LONGITUDE (Data Optional)
FROM_LATITUDE (Data Optional)
TO_LONGITUDE (Data Optional)
TO_LATITUDE (Data Optional)
SECTION_SPEED_LIMIT (Data Optional)
CURRENT_AADT (Data Optional)

STRIPING Data

DATE_STRIPED (Data Required)
ROADWAY_NAME (Data Required)
DIRECTION (I or D) (Data Required)
FROM_REF_POST_OFFSET (Data Required, if LATITUDE/LONGITUDE values don't exist)
TO_REF_POST_OFFSET (Data Required, if LATITUDE/LONGITUDE values don't exist)
STRIPER_CODE (Data Required)
LINE_TYPE_CODE (Data Required)
MARKING_TYPE_CODE (Data Required)
BEAD_TYPE_CODE (Data Optional)
GAL_WHITE_PAINT (Data Optional)
GAL_YELLOW_PAINT (Data Optional)
TOTAL_BEADS_LBS (Data Optional)
MILES_WHITE_PAINT (Data Optional)
MILES_YELLOW_PAINT (Data Optional)
COMMENTS (Data Optional)
FROM_LATITUDE (Data Optional)
FROM_LONGITUDE (Data Optional)
TO_LATITUDE (Data Optional)
TO_LONGITUDE (Data Optional)

Raw Data Preprocessing

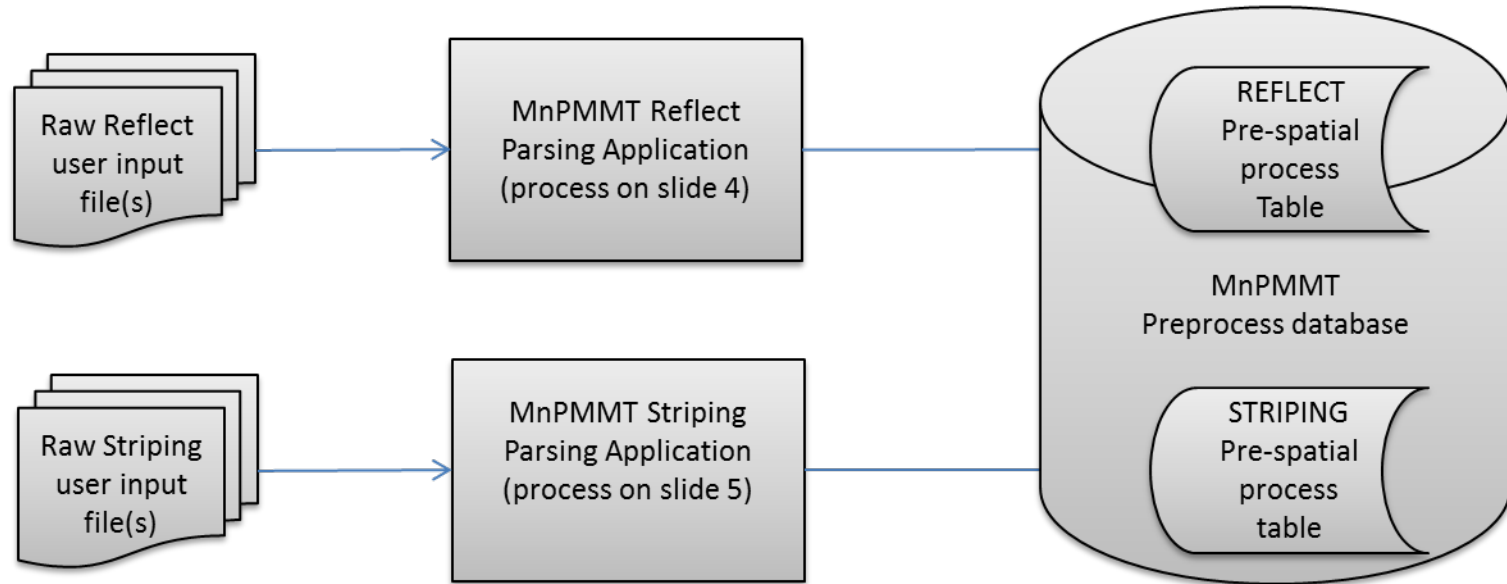

MnPMMT Reflect Parsing Application

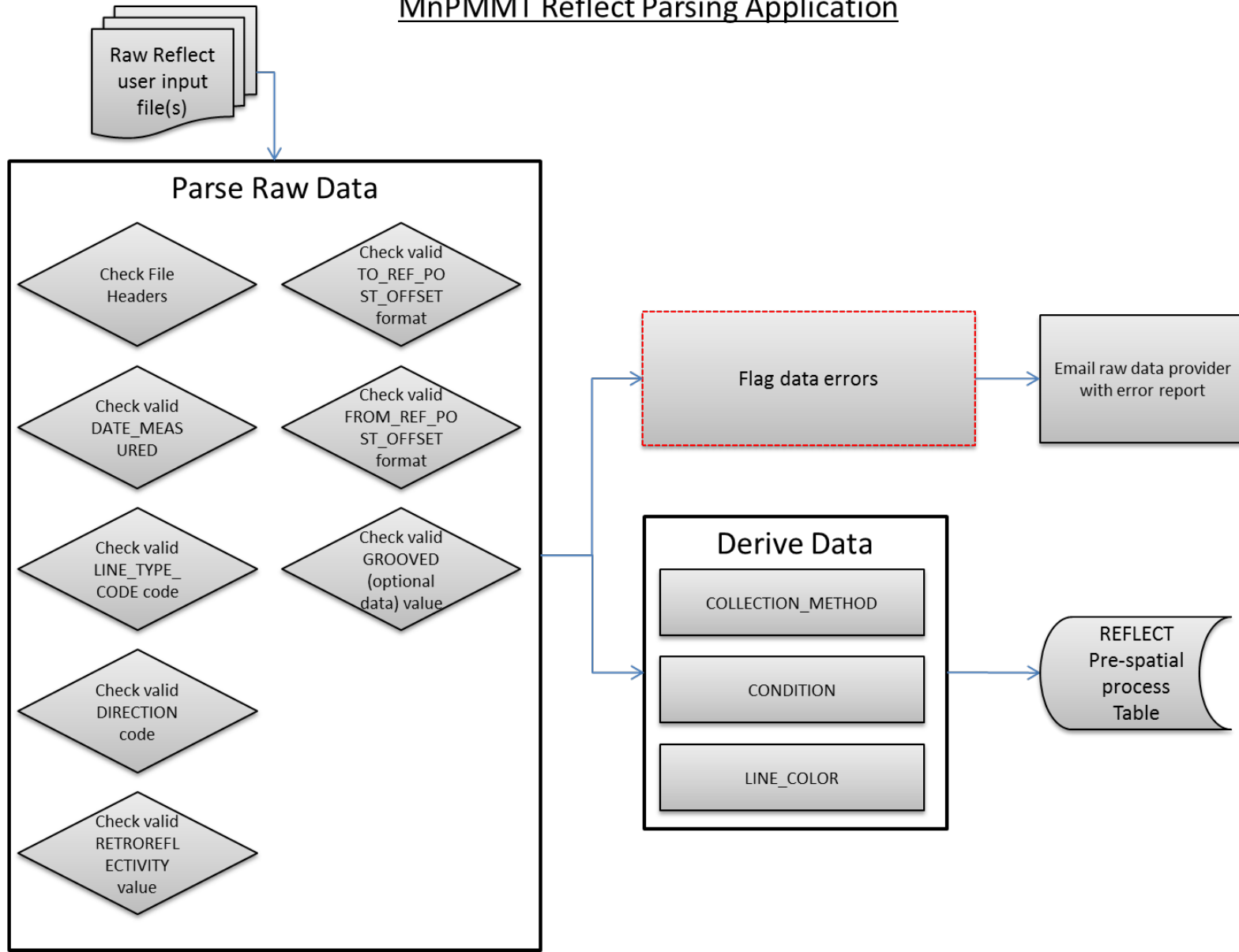

MnPMMT Striping Parsing Application

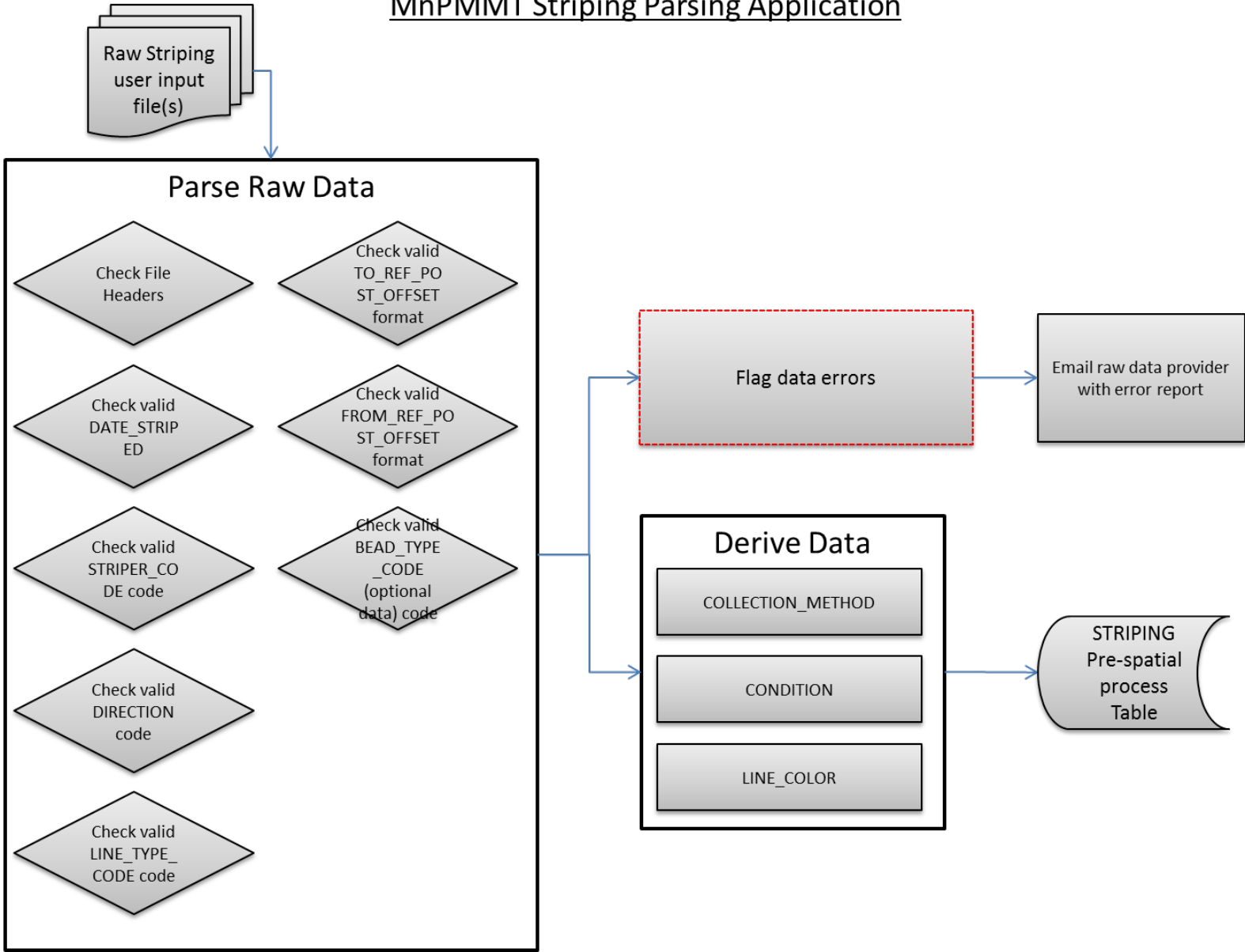

MnDOT Oracle Spatial Processing

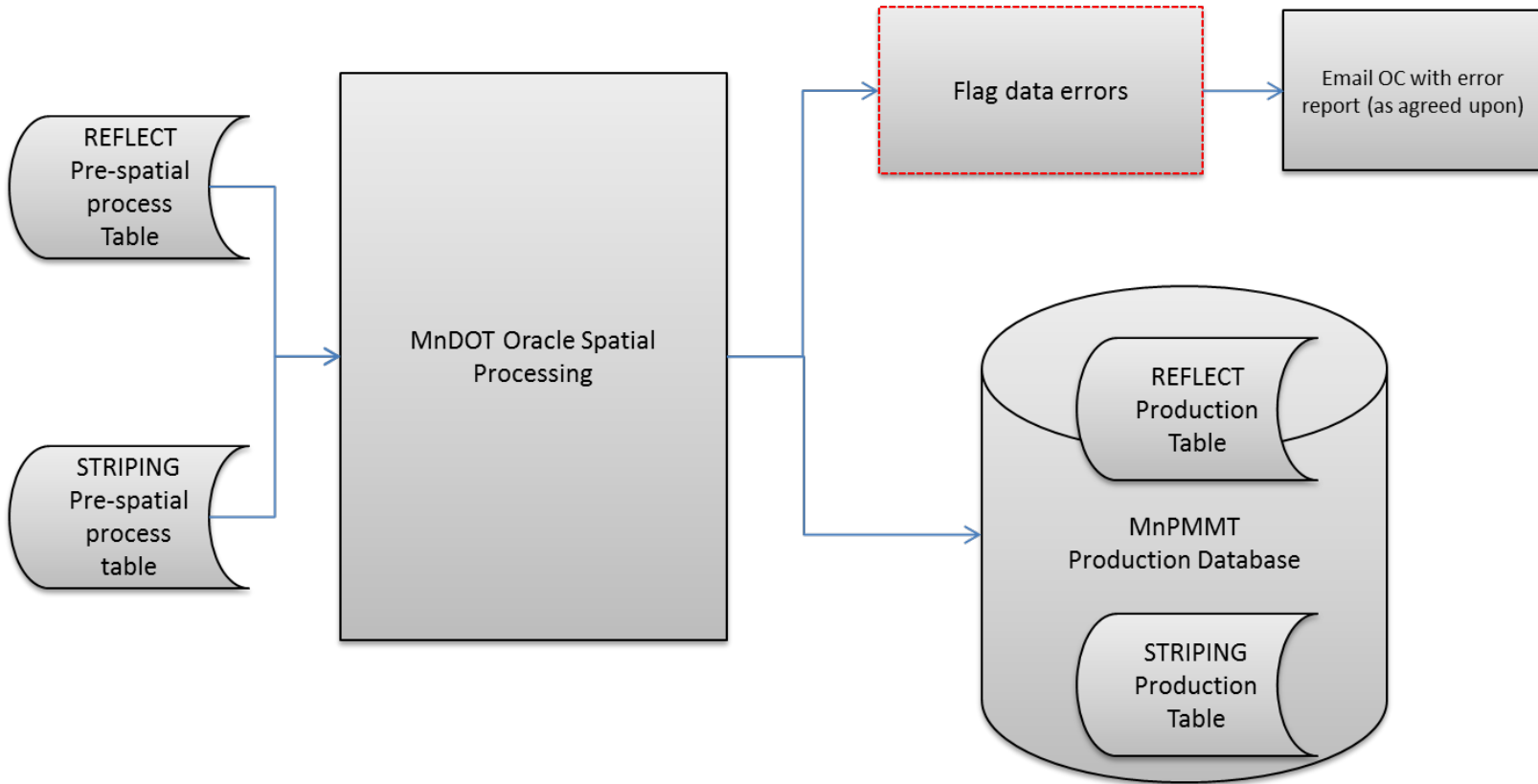

Physical Architecture Pavement Marking Management System

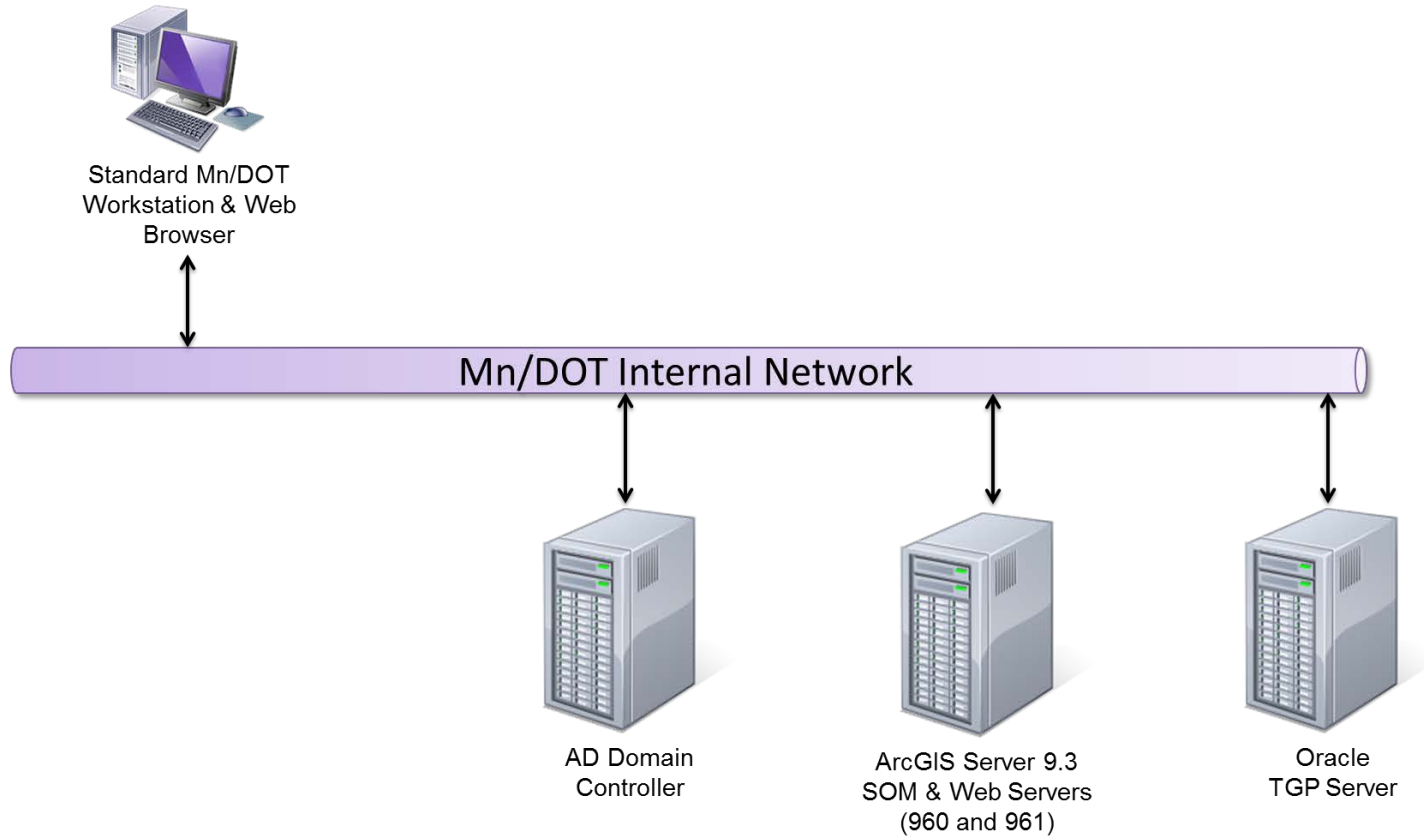

Logical Architecture (1 of 2) Pavement Marking Management System Web Data Upload Application and Parsing Tools

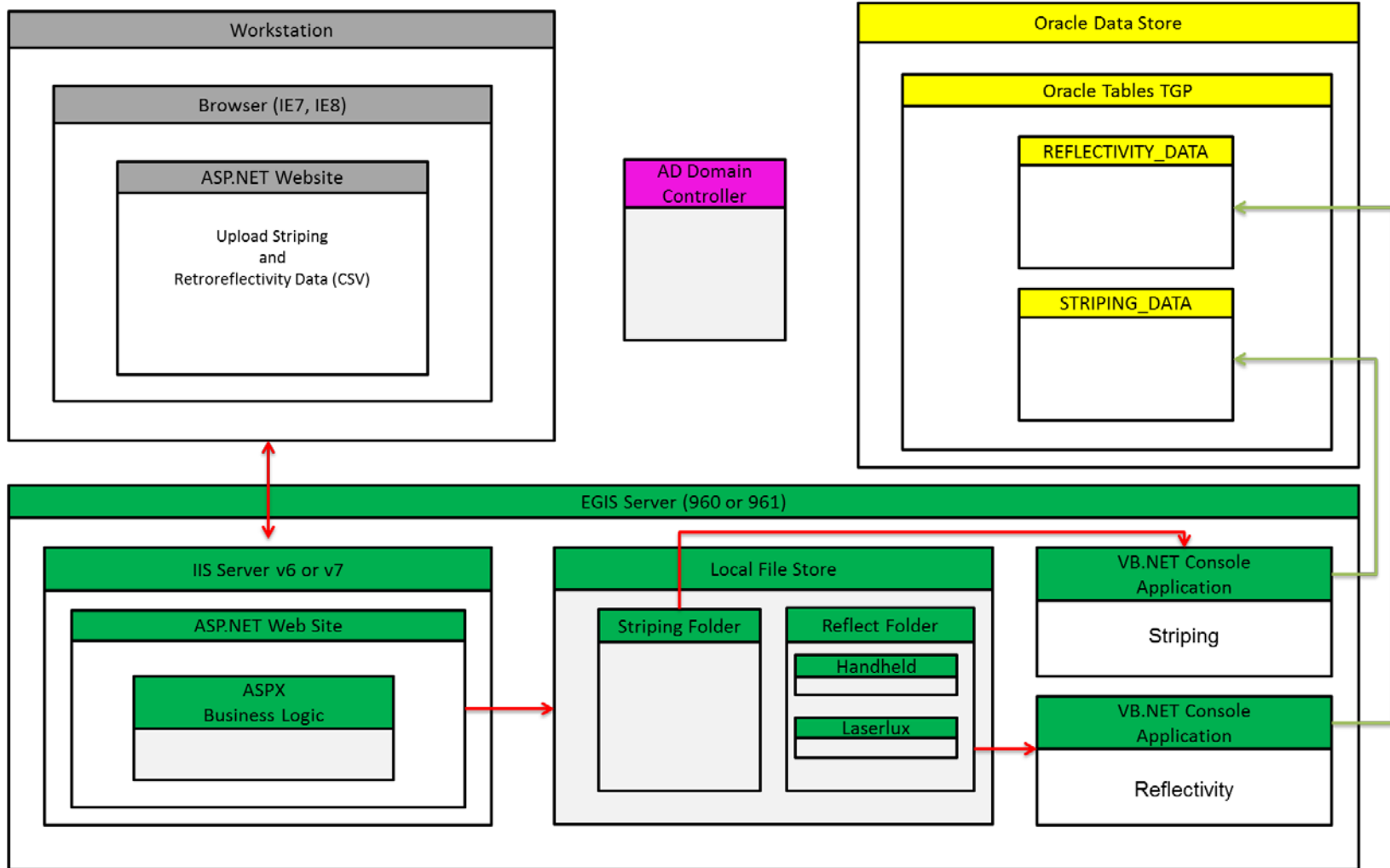

Logical Architecture (2 of 2)
Pavement Marking Management System
ArcGIS Web Application

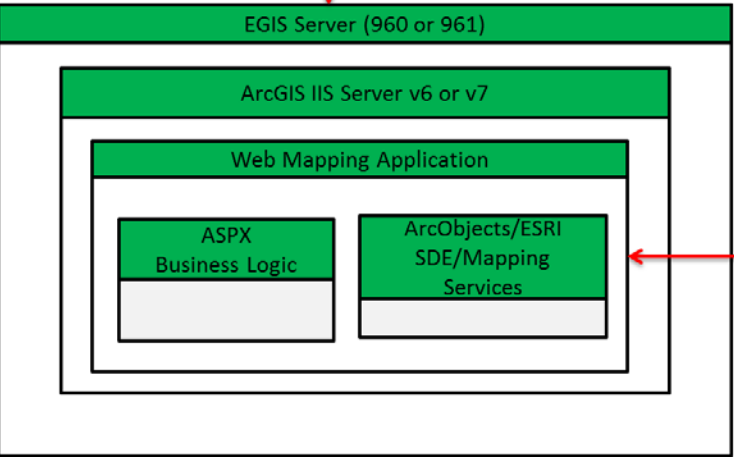
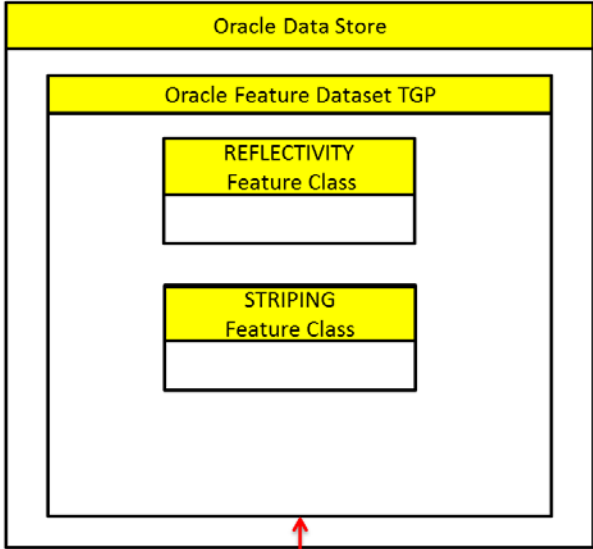
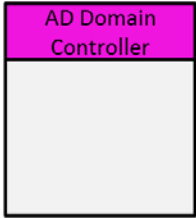
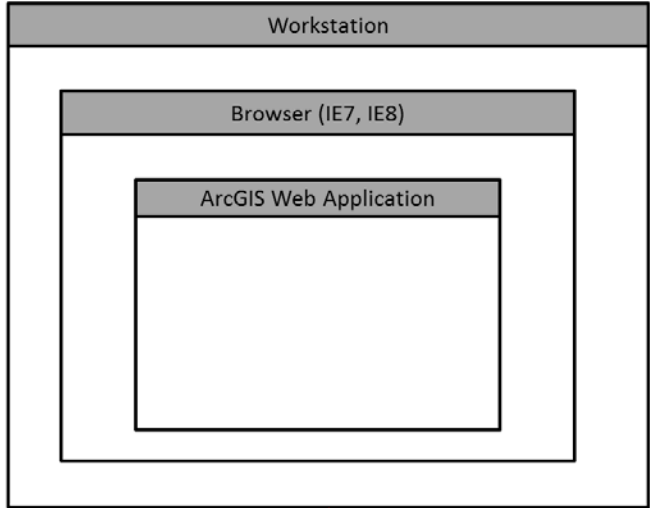

**Physical Data Model
Pavement Marking Management System
Raw Data Table**

REFLECTIVITY_DATA
Table

Field Name	Data Type	Allow Nulls	Default Value	Expected Code Values	Precision	Scale	Length
DATE_MEASURED	Date	No			0	0	8
ROUTE_SYSTEM_ABBR	String	No		SYSTEM_ABBRS			2
ROUTE_NUMBER	String	No					4
DIRECTION	String	No		DIRECTIONS			1
FROM_REF_POST_OFFSET	String	No					10
TO_REF_POST_OFFSET	String	No					10
LINE_TYPE_CODE	String	No		LINE_TYPES			3
RETROREFLECTIVITY	Double	No			4	1	
MARKING_TYPE_CODE	String	Yes		MARKING_TYPES			3
YEAR_LINE_INSTALLED	Long Integer	Yes			4		
YEAR_ROADWAY_BUILT	Long Integer	Yes			4		
GROOVED	String	Yes					3
RUMBLE_STRIPE	String	Yes					3
STANDARD_DEVIATION	Long Integer	Yes			3		
CONTRAST	String	Yes					3
PRESENCE	Integer	Yes			2		
COMMENTS	String	Yes					100
SURFACE_TYPE	String	Yes					50
FROM_LONGITUDE	Double	Yes			10	7	
FROM_LATITUDE	Double	Yes			10	7	
TO_LONGITUDE	Double	Yes			10	7	
TO_LATITUDE	Double	Yes			10	7	
SECTION_SPEED_LIMIT	Long Integer	Yes			2		
CURRENT_AADT	Long Integer	Yes			8		
COLLECTION_METHOD	Long Integer	No		COLLECTION_METHODS	1		
CONDITION	Long Integer	No		CONDITIONS	1		
LINE_COLOR	String	No		LINE_COLORS			1
CONTACT	String	No					50

STRIPING_DATA
Table

Field Name	Data Type	Allow Nulls	Default Value	Expected Code Values	Precision	Scale	Length
DATE_STRIPED	Date	No			0	0	8
ROUTE_SYSTEM_ABBR	String	No		SYSTEM_ABBRS			2
ROUTE_NUMBER	String	No					4
DIRECTION	String	No		DIRECTIONS			1
FROM_REF_POST_OFFSET	String	No					10
TO_REF_POST_OFFSET	String	No					10
LINE_TYPE_CODE	String	No		LINE_TYPES			3
STRIPER_CODE	Long Integer	No		STRIPER_CODES	1		
MARKING_TYPE_CODE	String	No		MARKING_TYPES			3
YEAR_ROADWAY_BUILT	Long Integer	Yes			4		
BEAD_TYPE_CODE	Long Integer	Yes			3		
GALLONS_OF_PAINT	Double	Yes			6	3	
TOTAL_BEAD_LBS	Double	Yes			6	3	
MILES_OF_PAINT	Double	Yes			6	3	
COMMENTS	String	Yes					100
FROM_LONGITUDE	Double	Yes			10	7	
FROM_LATITUDE	Double	Yes			10	7	
TO_LONGITUDE	Double	Yes			10	7	
TO_LATITUDE	Double	Yes			10	7	
LINE_COLOR	String	No		LINE_COLORS			1
CONTACT	String	No					50

SYSTEM_ABBRS

1 = Interstate
US = US Trunk
MN = Minnesota Trunk

DIRECTIONS

I = Increasing
D = Decreasing

COLLECTION_METHODS

1 = Mobile
2 = Handheld

LINE_TYPES

CL = Center Line
REL = Right Edge Line
LEL = Left Edge Line
LL = Lane Line
1LL = First Lane Line
2LL = Second Lane Line
3LL = Third Lane Line

MARKING_TYPES

E = Epoxy Paint
L = Latex Paint
T = Tape
TH = Thermoplastic
PU = Polyurea Paint
MMA = Methyl Methacrylate

CONDITIONS

1 = Poor
2 = Fair
3 = Good

LINE_COLORS

W = White
Y = Yellow

STRIPER_CODES

1 = MIDOT Central Striping
2 = AAA
3 = Highway Technologies
4 = Century Fence
5 = Traffic Marking Services
6 = Swenson
7 = Geyer signal
8 = Safety Signs
9 = West River
10 = Northstar Safety
11 = Highway Solutions
12 = Ames
13 = United Rentals
14 = Damnick
15 = McLaughlin & Schultz
16 = PCI
17 = Hammerhead
18 = Mathiowetz
19 = Dakota Traffic
20 = Lunds Construction
21 = Dalchn Traffic

**Physical Data Model
Pavement Marking Management System
Feature Dataset**

MnDOT_PMMT

Simple feature class
MnDOT_PMMT_REFLECTIVITY
Geometry: Polyline
Contains M values: Yes
Constraints: Z values: No

Field Name	Data Type	Allow Nulls	Default Value	Domain	Precision	Scale	Length
OBJECTID	ObjectID						
SHAPE	Geometry	Yes					
ROUTE_ID	String	No					11
CONST_DISTRICT_CODE	String	No		DISTRICT_CODES			1
FROM_TRUE_MILES	Double	No			6	3	
TO_TRUE_MILES	Double	No			6	3	
DATE_MEASURED	Date	No			0	0	8
ROUTE_SYSTEM_ABBR	String	No					2
ROUTE_NUMBER	String	No					4
DIRECTION	String	No					1
FROM_REF_POST_OFFSET	String	No					10
TO_REF_POST_OFFSET	String	No					10
LINE_TYPE_CODE	String	No		LINE_TYPES			3
RETROREFLECTIVITY	Double	No			5	1	
MARKING_TYPE_CODE	String	Yes		MARKING_TYPES			3
YEAR_LINE_INSTALLED	Long Integer	Yes			4		
YEAR_ROADWAY_BUILT	Long Integer	Yes			4		
GROOVED	String	Yes					3
RUMBLE_STRIPE	String	Yes					3
STANDARD_DEVIATION	Long Integer	Yes			3		
CONTRAST	String	Yes					3
PRESENCE	Integer	Yes			2		
COMMENTS	String	Yes					100
SURFACE_TYPE	String	Yes					50
FROM_LONGITUDE	Double	Yes			10	7	
FROM_LATITUDE	Double	Yes			10	7	
TO_LONGITUDE	Double	Yes			10	7	
TO_LATITUDE	Double	Yes			10	7	
SECTION_SPEED_LIMIT	Long Integer	Yes			2		
CURRENT_AADT	Long Integer	Yes			8		
COLLECTION_METHOD	Long Integer	No		COLLECTION_METHODS	1		
CONDITION	Long Integer	No		CONDITIONS	1		
LINE_COLOR	String	No					1
CONTACT	String	No					50

Simple feature class
MnDOT_PMMT_STRIPING
Geometry: Polyline
Contains M values: Yes
Constraints: Z values: No

Field Name	Data Type	Allow Nulls	Default Value	Domain	Precision	Scale	Length
OBJECTID	ObjectID						
SHAPE	Geometry	Yes					
ROUTE_ID	String	No					11
CONST_DISTRICT_CODE	String	No		DISTRICT_CODES			1
FROM_TRUE_MILES	Double	No			6	3	
TO_TRUE_MILES	Double	No			6	3	
DATE_STRIPED	Date	No			0	0	8
ROUTE_SYSTEM_ABBR	String	No					2
ROUTE_NUMBER	String	No					4
DIRECTION	String	No					1
FROM_REF_POST_OFFSET	String	No					10
TO_REF_POST_OFFSET	String	No					10
LINE_TYPE_CODE	String	No		LINE_TYPES			3
STRIPER_CODE	Long Integer	No		STRIPER_CODES	1		
MARKING_TYPE_CODE	String	No		MARKING_TYPES			3
YEAR_ROADWAY_BUILT	Long Integer	Yes			4		
BEAD_TYPE_CODE	Long Integer	Yes			3		
GALLONS_OF_PAINT	Double	Yes			6	3	
TOTAL_BEAD_LRS	Double	Yes			6	3	
MILES_OF_PAINT	Double	Yes			6	3	
COMMENTS	String	Yes					100
FROM_LONGITUDE	Double	Yes			10	7	
FROM_LATITUDE	Double	Yes			10	7	
TO_LONGITUDE	Double	Yes			10	7	
TO_LATITUDE	Double	Yes			10	7	
LINE_COLOR	String	No					1
CONTACT	String	No					50

DISTRICT_CODES
(Dist. Code)

M	Metro
1	Duluth
2	Bemidji
3	Brainerd
4	Detroit Lakes
6	Rochester
7	Mankato
8	Willmar

LINE_TYPES
(Line Type)

CL	Center Line
REL	Right Edge Line
LEL	Left Edge Line
LL	Lane Line
1LL	First Lane Line
2LL	Second Lane Line
3LL	Third Lane Line

MARKING_TYPES
(Mark. Type)

E	Epoxy Paint
L	Latex Paint
T	Tape
TM	Thermoplastic
PU	Polyurea Paint
MMA	Methyl Methacrylate

CONDITIONS
(Cond. Code)

1	Poor
2	Fair
3	Good

STRIPER_CODES
(Striper Code)

- MnDOT Central Striping
- AAA
- Highway Technologies
- Century Fence
- Traffic Marking Services
- Swanson
- Geyer Signal
- Safety Signs
- West River
- Northstar Safety
- Highway Solutions
- Ames
- United Rentals
- Damnick
- McLaughlin & Schultz
- PCI
- Heimerhead
- Methowetz
- Dakota Traffic
- Lunda Construction
- Dalchin Traffic

BEAD_MATERIALS
Table

Field Name	Data Type	Allow Nulls	Default Value	Precision	Scale	Length
ID	Long Integer	No		3		
BEAD_NAME	String	No				2
MANUFACTURER	String	No				4
APPROVAL_DATE	String	No				50
NOTES	String	Yes				100

COLLECTION_METHODS
(Coll. Method)

1	Mobile
2	Handheld

Appendix B – MnDOT Data Logging System (DLS) Specifications

(2582) PERMANENT PAVEMENT MARKINGS

Use SP2005-257 (EPOXY PAV'T. MARKINGS (FREE OF TOXIC HEAVY METALS)), SP2005-258 (HIGH SOLIDS WATER-BASED PAINT), and SP2005-259 (DROP-ON GLASS BEADS) with this writeup. If the job is a signal only, then check to see if new pavement markings are shown on the plan or are in the Division SS. If there are new pavement markings on the signal job but there is no pay items on the plan for them, then only use S-.1 thru S-.4.

REVISED 2/7/08

SP2005-248

The provisions of MnDOT 2582 are hereby modified and/or supplemented with the following:

The provisions of MnDOT 2582.2 are hereby deleted and replaced with the following:

- A Preformed Plastic Markings for Permanent Traffic Lane Delineation and Legends.....3354**
- B Epoxy Resin Pavement Markings (Free of Toxic Heavy Metals)3590**
- C High Solids Water-Based Traffic Paint.....3591**
- D Drop-On Glass Beads.....3592**

Qualified materials can be found on MnDOT's Qualified Products List on the Office of Traffic, Safety and Technology website. Other materials may be used on a provisional basis as detailed in the QPL process and as approved by the Engineer. Type of material used will be as specified by Contract Documents.

MnDOT 2582.3A2 is hereby deleted.

The following is hereby added to MnDOT 2582.3B, Application:

Any pavement markings to be grooved in shall be placed in accordance with manufacturer's instructions.

MnDOT 2582.3C3 is hereby deleted and replaced with the following:

Provide pavement markings meeting the following minimum initial pavement marking retroreflectivity when tested using 30 m geometry in accordance with ASTM E 1710:

Table 2582-1 Minimum Initial Pavement Marking Retroreflectivity		
	White	Yellow
Tape	600 mcd/sq. m/lux	500 mcd/sq. m/lux
Epoxy	300 mcd/sq. m/lux	200 mcd/sq. m/lux
Latex	275 mcd/sq. m/lux	180 mcd/sq. m/lux

Use below language when the project is at least 1 centerline mile in length.

Mobile Retroreflector Measurements (MRM)

Retroreflectivity measurements of longitudinal markings shall be provided by the Contractor utilizing an independent Contractor using a vehicle-mounted mobile retroreflector utilizing 30 meter CEN geometry in accordance with ASTM E 1710-95 (Standard Test Method for Measurement of Retroreflective Pavement Markings Materials with CEN-Prescribed Geometry Reflectometers). The retroreflector shall be calibrated no less than twice a day in accordance with the operating manual and calibration guide for the particular machine and vehicle. Measurement shall consist of the average retroreflective readings and standard deviations over 1 mile intervals (or over the length of the line if shorter than 1 mile) for each type of pavement marking placed under this contract.

The measurement report will include:

1. State Project Number,
2. Date and time of data collection,
3. The highway number with the beginning and ending reference points of data collection rounded to the nearest thousandths of a mile and the beginning and ending coordinates determined by a Global Positioning System receiver with 3 meter accuracy, including the direction of travel in terms of increasing or decreasing reference points,
4. Which line is being read (LEL – Left Edgeline, REL – Right Edgeline, CL, Centerline, LL – Lane Line Skip, 1LL – left most LL in multilane, 2LL – second to left most LL in multilane, etc),
5. The 0.1 mile station averages and standard deviations,
6. A summary of the average retroreflective readings in one mile increments.

The measurement report will in the form of an electronic database file, or delimited text file, containing all raw data collected. The electronic file must also contain a summary that is capable of being directly uploaded to the Department's Pavement Marking Management Tool (PMMT) database. The data shall be submitted and accepted into the PMMT at the following intranet website: <http://gisservices/mnppmmt/>. A printed record of the summary shall also be provided to the Engineer at the Engineer's discretion.

The evaluation of retroreflectivity will be conducted at least 14 days after installation. Excess beads or reflective elements must not be visible before the retroreflectivity testing is conducted.

Data shall be collected when pavement and markings are dry, clean and no visible moisture is on the road surface. These criteria define initial pavement marking retroreflectivity values. Centerline markings shall be measured in both directions. Other longitudinal markings shall be measured in the direction of intended vehicular travel.

Any replaced markings will also need to be evaluated at no additional cost per this special provision.

The Mobile Retroreflector Measurements, including but not limited to materials, equipment, labor and time, will be measured based on the Linear Foot. The Linear Foot will be measured for the distance travelled by the mobile retroreflector as it measures the retroreflectivity of the pavement marking. This assumes one laser instrument on one van that will read one line with each pass. For a one mile section of two-lane, two-way roadway this would need four (4) passes – First Direction: REL and CL, Second Direction: REL and CL - equating to 21120 linear feet.

No payment for pavement markings shall be made until the evaluation of retroreflectivity is complete and the work accepted by the Engineer.

MnDOT 2582.3F is hereby deleted and replaced with the following:

Remove and replace, or repair, pavement markings not meeting the minimum initial pavement marking retroreflectivity values in accordance with Table 2582-1, as approved by the Engineer at no additional cost the Department.

If the retroreflectivity deficiency is no greater than 20 percent, the Engineer may accept the work at a unit price reduced by the percent of retroreflectivity deficiency.

MnDOT 2582.3G is hereby deleted and replaced with the following:

Construction Striper Operations Daily Log

Contractors applying pavement markings for MnDOT under a contract **are required** to fill out the "Construction Striper Operations Daily Log" form which is shown in the special provisions and as approved by the Engineer.

AND/OR

Use when project includes liquid markings and is at least 1 centerline mile in length. The Construction Striper Operations Daily Log is required for Tape systems.

Striper Computerized Data Logging System for Liquid Markings (DLS)

The pavement marking device shall have an onboard monitoring system for the purpose of managing the amount of striping materials being applied to a surface. Data shall be collected for any pavement marking application of 300 feet (drive length) or greater.

The following data shall be included in the documentation from the DLS:

1. State Project Number,
2. For every highway marked, the highway number with the beginning and ending reference points rounded to the nearest thousandths of a mile and the beginning and ending coordinates determined by a Global Positioning System receiver with 3 meter accuracy, including the direction of travel in terms of increasing or decreasing reference points,
3. Date, and beginning and ending time of application,
4. Vendor and product (binder and reflective material),
5. Lot number(s) of product used,
6. Striping contractor (striper code),
7. Designation of the marking being applied (LEL – Left Edgeline, REL – Right Edgeline, CL - Centerline, LL – Lane Line Skip, 1LL – left most LL in multilane, 2LL – second to left most LL in multilane, etc),
8. Width of marking being applied,
9. Presence of groove or rumble strip (if pavement marking is being installed on top of, begin and end points of groove or rumble will be recorded by GPS),

The following data shall be reported as an average for each drive mile installed:

10. Application vehicle speed to the nearest 0.1 MPH,
11. Weight (LBS) and/or volume (GAL as measured through a positive displacement pump mechanism or flow meter) of liquid material(s) used by color,
12. Weight (LBS) of reflective material used,
13. Ratio of reflective material used (weight) per liquid material used (volume) reported as LBS/GAL,
14. Ambient air temperature (in degrees Fahrenheit),

15. Road surface temperature (in degrees Fahrenheit),
16. Humidity (%),
17. The system shall record the average material application rates and film thickness calculated over the section striped, and

This system shall be capable of storing data and exporting to the Department’s Pavement Marking Management Tool (PMMT) and the data shall be submitted into the PMMT daily at the following web address: <http://gisservices/mnppmmt/>. A printed record of the data shall also be provided to the Engineer at the Engineer’s discretion. The printed and electronic records shall be produced in their final form prior to the records being removed from the pavement marking equipment.

The Contractor shall provide the Engineer the above records for all longitudinal non-handwork lines installed.

The Contractor shall have equipment with functional DLS equipment that is operational, calibrated and in use during pavement marking operations. Pavement marking installation without the use of a DLS shall constitute unauthorized work under 1512.

The Contractor shall provide the Engineer the DLS manufacturer’s recommendations for equipment calibration frequency and provide certification that the equipment meets manufacturer’s recommended calibration.

A 100 foot distance shall be travelled prior to the start of pavement marking operations to verify the physical and electronic measurement of distance travelled is consistent.

The Striper Computerized Data Logging System shall be incidental to permanent pavement marking operations for which no direct payment will be made.

The provisions of MnDOT 2582.5 are hereby deleted and replaced with the following:

2582.5 BASIS OF PAYMENT

Payment for pavement markings installed at Contract prices per unit of material shall be compensation in full for all costs incurred in materials, traffic control, installation, surface preparation, use of primers, in accordance to Contract documents or as approved by the Engineer.

Payment for the retroreflectivity evaluated at Contract prices per unit shall be compensation in full for all costs incurred in materials, equipment, labor, traffic control and time in accordance to Contract documents or as approved by the Engineer.

<u>ITEM NO.</u>	<u>ITEM</u>	<u>UNIT</u>
2582.501	Pavement Message (1) (2)	Each
2582.502	__ mm (__ inch) width (3) (4) (2)	meter (linear foot)
2582.503	Crosswalk Marking - (2)	square meter (square foot)
2582.603	Mobile Retroreflectometer Measurements	linear foot
(1)	Specify Message	
(2)	Specify Material	
(3)	Specified Type of Line (Solid, Broken or Dotted)	
(4)	Specify Color	