



Minnesota  
Department of  
Transportation

**RESEARCH  
SERVICES**

Office of  
Policy Analysis,  
Research &  
Innovation

# Development of an Advanced Structural Monitoring System

Arturo Schultz, Principal Investigator  
Department of Civil Engineering  
University of Minnesota

**November 2010**

Research Project  
Final Report #2010-39

*Your Destination... Our Priority*



## Technical Report Documentation Page

1. Report No. MN/RC 2010-39	2.	3. Recipients Accession No.	
4. Title and Subtitle Development of an Advanced Structural Monitoring System		5. Report Date November 2010	
		6.	
7. Author(s) Arturo Schultz, David Thompson		8. Performing Organization Report No.	
9. Performing Organization Name and Address Department of Civil Engineering University of Minnesota 500 Pillsbury Dr. SE Minneapolis, MN 55455		10. Project/Task/Work Unit No. CTS Project #2010013	
		11. Contract (C) or Grant (G) No. (c) 89261 (wo) 144	
12. Sponsoring Organization Name and Address Minnesota Department of Transportation Research Services Section 395 John Ireland Blvd, MS 330 St. Paul, MN 55155		13. Type of Report and Period Covered Final Report	
		14. Sponsoring Agency Code	
15. Supplementary Notes <a href="http://www.lrrb.org/pdf/201039.pdf">http://www.lrrb.org/pdf/201039.pdf</a>			
16. Abstract (Limit: 250 words)  <p>With bridge infrastructure in Minnesota aging, advancing techniques for ensuring the safety of bridges and motorists is a fundamental goal of the Minnesota Department of Transportation (Mn/DOT). As such, developing health monitoring systems for fracture critical bridges is an essential objective in meeting the stated goal. This report applies the methodology and uses the information of a previous Mn/DOT report to investigate, select, and design a bridge health monitoring system for the Cedar Avenue Bridge which is a fracture critical tied arch bridge in Burnsville, Minnesota. An investigation of monitoring needs for the Cedar Avenue Bridge was undertaken. In addition, the authors reviewed literature with the goal of determining the most applicable monitoring technology that is commercially available and which fulfills the required bridge monitoring needs. Once a monitoring technology was selected, the authors selected a vendor, using a computer-based program developed in the aforementioned Mn/DOT report, to select a suggested system of monitoring equipment for Mn/DOT to purchase. Finally, the report describes multiple alternatives for monitoring scales, scopes, locations, and capabilities, with global monitoring of the most critical members and connections of the bridge as the authors' recommendation. A procedure for installation of the suggested bridge health monitoring system follows the authors' recommendations and is applicable to any of the monitoring alternatives presented in this report.</p>			
17. Document Analysis/Descriptors Bridges, Acoustic emission, Structural health monitoring, Fracture critical bridges		18. Availability Statement No restrictions. Document available from: National Technical Information Services, Alexandria, Virginia 22312	
19. Security Class (this report) Unclassified	20. Security Class (this page) Unclassified	21. No. of Pages 66	22. Price

# **Development of an Advanced Structural Monitoring System**

## **Final Report**

*Prepared by:*

Arturo E. Schultz  
David J. Thompson

Department of Civil Engineering  
University of Minnesota

**November 2010**

*Published by:*

Minnesota Department of Transportation  
Research Services Section  
395 John Ireland Boulevard  
St. Paul, Minnesota 55155

This report represents the results of research conducted by the authors and does not necessarily represent the views or policies of the Minnesota Department of Transportation or the University of Minnesota. This report does not contain a standard or specified technique.

The authors, the Minnesota Department of Transportation, and the University of Minnesota do not endorse products or manufacturers. Any trade or manufacturers' names that may appear herein do so solely because they are considered essential to this report.

## **Acknowledgements**

The authors would like to thank the Minnesota Department of Transportation for funding this project. The authors would also like to thank the Technical Advisory Panel (TAP) members for their help and guidance during the development of this report: Moises Dimaculangan, Shirlee Sherkow, Todd Niemann, Tom Styrbicki, Paul Kivisto, Dave Dahlberg, Duane Green, Jihshya Lin, Nelson Cruz, and Kevin Western. Finally, the authors would like to thank the researchers that willingly completed satisfaction surveys and Mistras Group for its assistance and guidance in the design of the monitoring system.

## Table of Contents

1	Introduction .....	1
1.1	Project Scope, Objective, and Requirements .....	1
1.2	Motivation for Report.....	1
1.3	Overview of Chapters.....	1
2	Bridge Selection and Monitoring Requirements .....	3
2.1	Bridge Selection .....	3
2.2	Nature of Monitoring .....	3
2.3	Bridge Type and Components for Monitoring.....	3
2.4	Type of Monitoring System .....	4
3	Monitoring System and Vendor Selection.....	5
3.1	System and Vendor Selection Methodology .....	5
3.2	Technology Analysis.....	5
3.3	Suggested Vendors.....	5
3.4	Vendor Product Comparison.....	8
3.5	Vendor Client Experience .....	9
4	System Design.....	11
4.1	Finite Element Model Formulation for Local Monitoring .....	11
4.2	Global Finite Element Model Calibration.....	11
4.3	Global Finite Element Model Development and Results.....	13
4.4	Local Finite Element Model Development and Results.....	15
4.5	System Selection .....	16
4.6	System Installation for Local Monitoring .....	16
4.7	System Installation for Global Monitoring .....	20
4.8	Distress Response.....	21
4.9	System Inspection and Maintenance .....	21
5	Acoustic Emission Monitoring Capabilities.....	22
5.1	AE Source Location .....	22
5.2	AE Signal Characterization.....	23
6	Implementation Plan.....	26
6.1	System Pricing.....	26

6.2	Installation Schedule .....	27
6.3	Installation Procedure.....	27
6.4	Initial Testing and Verification .....	27
6.5	Maintenance Plan .....	27
7	Summary, Conclusions and Recommendations .....	28
7.1	Summary and Conclusions.....	28
7.2	Recommendations .....	28
	References.....	30
	Appendix A: Vendor Satisfaction Surveys	
	Appendix B: Monitoring System Implementation Plan	
	Appendix C: Mistras Group System Quotes	

## **List of Tables**

Table 3.1. Weight Considerations and Results .....	6
Table 3.2. Mistras Client Satisfaction Rating Survey Results .....	10
Table 4.1. Arch Rib Subjected to Dead Load .....	12
Table 4.2. Floor Beam Subjected to Dead Load .....	12
Table 4.3. Hangers Subjected to Dead Load.....	13
Table 4.4. Arch Tie Box Girder Subjected to Dead Load .....	13
Table 6.1. System Pricing Breakdown.....	26

## **List of Figures**

Figure 4.1. Profile View of Cedar Ave. Bridge .....	12
Figure 4.2. Isometric View of Cedar Ave. Bridge.....	14
Figure 4.3. Moment Distribution in Global SAP2000 Model for Dead Load .....	14
Figure 4.4. Moment Distribution in Global SAP2000 Model for Combined Load.....	14
Figure 4.5. 3D SAP2000 Model of L3 Connection (Box Girder Exterior) .....	15
Figure 4.6. 3D SAP2000 Model of L3 Connection (Box Girder Interior) .....	16
Figure 4.7. Plan View of Cedar Ave. Bridge.....	17
Figure 4.8. Section B (Alternative 1 AE Sensor Location) .....	17
Figure 4.9. Section B (Alternative 2 AE Sensor Location) .....	18
Figure 4.10. Section B (Alternative 3 AE Sensor Location) .....	18
Figure 4.11. Section C (SH-II Module Location) .....	19
Figure 4.12. Section D (Solar Panel Installation) .....	19
Figure 5.1. Definition of Acoustic Emission Parameters .....	24

## **Executive Summary**

This report aims to demonstrate a method previously developed for the Minnesota Department of Transportation (Mn/DOT) for the selection of bridge health monitoring systems for fracture critical bridges. An advanced warning monitoring system is selected and the corresponding monitoring plan was designed for the Cedar Avenue Bridge in Burnsville, Minnesota. The Cedar Avenue Bridge features steel arches that are tied with steel box girders and qualifies as a fracture critical bridge. The monitoring system, coupled with inspection, serves to provide advance warning of structural distress to allow for bridge repair or if necessary bridge closure. The intent of advance warning is to prevent loss of life and loss of property for both bridge users and bridge owners.

This report incorporates monitoring system and vendor evaluation criteria developed by the authors of Mn/DOT research project (Bridge Health Monitoring and Inspection – A Survey of Methods). This report will explore all possible advanced warning monitoring technology and identify the one that best suits the monitoring needs of the bridge and monitoring requirements of Mn/DOT. Once a monitoring technology is selected, suitable vendors are determined using a selection program developed using Microsoft EXCEL by the authors of Bridge Health Monitoring and Inspection – A Survey of Methods. The ‘best’ vendor is selected, using the EXCEL program and criteria (customer satisfaction survey) developed by the authors of this report. This report also includes the response to the customer satisfaction surveys.

With a monitoring system and vendor selected, the authors of this project suggested two suitable installation plans for the monitoring system. Both installation plans are for monitoring the bridge’s most critical structural members. The first plan identifies possible areas of future distress that may warrant local monitoring, and the second plan provides global monitoring of all critical members. Both alternatives seek to achieve the same goal (monitoring for the purpose of providing advanced warning of failure) with the differences being cost and scale. Included in the installation plan are specifications for the installation of the monitoring device on the bridge, powering the monitoring device, initial testing and calibration of the monitoring device, and maintenance of the monitoring device. Selections based on suggestions made for technology type, vendor, and installation plan are at the discretion of Mn/DOT. However, the report does not detail the selections made by Mn/DOT in the process of completing this report.

The report also explains the capabilities of the selected monitoring device. Included in this explanation is: an example of a typical distress signal, the extractable parameters from the distress signal, and how to translate these parameters to identify the type of structural distress. This information is provided to assist the monitoring system user with initial testing of the system and setting up advance warning capabilities of the system.



# 1 Introduction

## 1.1 Project Scope, Objective, and Requirements

The purpose of this project is to explore the developments in advance warning monitoring technology in order to select the most suitable monitoring technology for a specific fracture critical bridge. The selected bridge must be fracture critical in its design (lacking redundancy) and of the tied arch bridge type. The bridge selected must also be expected to remain in service for another decade. The potential catastrophic flaws of the bridge's design and aging must be determined. Ultimately, the monitoring technology selected must be capable of providing advance warning for structural distress due to either design flaws or aging (i.e. fatigue cracks, corrosion, and fracture of welds). With the monitoring technology determined, a suitable vendor must then be selected. The vendor must be able to provide a complete monitoring system. That is, the vendor must be able to provide all necessary equipment and software for monitoring of the selected bridge. The list of required equipment provided by the vendor includes, but is not limited to: monitoring instruments, data-logging equipment, advance warning capabilities, if necessary wireless data transferring capabilities, if necessary power equipment (solar, battery, etc.), and software. The selected system then must be designed to provide advance warning of structural distress in critical members to prevent the catastrophic loss of property and life. The approved design will then be developed into an implementation plan that details the installation of the monitoring system.

## 1.2 Motivation for Report

In wake of the tragic collapse of the I-35W Bridge in August 2007, it is the goal of Mn/DOT to develop capable and cost effective methods for monitoring fracture critical bridges. Knowing, in general, typical structural distress of bridges, this report aims to determine the best monitoring technology for use on the bridge selected for this report, and it intends to serve as a model and forward for future bridge monitoring projects.

## 1.3 Overview of Chapters

Chapter 2 details the work completed on the selection of a suitable bridge to be monitored and the requirements for the monitoring technology. Many requirements of the monitoring technology are a function of the bridge selected, which is explained in the chapter. The chapter also introduces the EXCEL program that will be used to select the vendor to provide the monitoring system. The chapter follows the sections of input required for completion of the EXCEL program.

Chapter 3 describes the selection of the monitoring technology and vendor. The chapter begins with an investigation of current monitoring technologies, specifically those that offer advance warning capabilities. Next the EXCEL program is executed, using the information detailed in Chapter 2, and a list of suitable vendors is generated. Chapter 3 contains a product comparison between all suitable vendors, where the three most qualified vendors are selected to complete customer satisfaction surveys. The results of the satisfaction surveys are provided in Chapter 3, and the 'best' vendor is selected to provide the monitoring system.

Chapter 4 details the design of the monitoring system. The system design includes exploring a local monitoring system (monitoring 'hot spots'), and a global monitoring system (monitoring the bridge's critical members). Chapter 4 also includes a suitable response to signals of distress from the monitoring system.

Chapter 5 explains the capabilities of the selected monitoring technology. This explanation includes: typical signal types the monitoring system will receive, how the signals are evaluated, and how to use the data to provide advance warning. This chapter serves to provide background knowledge for the user that monitors the selected bridge.

Chapter 6 contains the potential cost of the monitoring system, as well as specifications for the installation of the system. Included in the specifications for installation is a schedule detailing in what order the monitoring system is to be installed. Also, the procedure for initial testing and verification of the system are included in Chapter 6. Chapter 6 also includes a maintenance plan for the monitoring system.

## **2 Bridge Selection and Monitoring Requirements**

This chapter identifies the bridge selected for investigation in this report. The following chapter contains a written description of the input parameters for the questionnaire EXCEL file, developed in Bridge Health Monitoring and Inspection – A Survey of Methods, which will be used for vendor selection. The bridge health monitoring system type and vendor is to be determined by implementing the methodology and completing the questionnaire from Bridge Health Monitoring and Inspection – A Survey of Methods.

### **2.1 Bridge Selection**

Fulfilling the requirements of the scope of work for this project and in consultation with the Minnesota Department of Transportation Office of Bridges and Structures (Mn/DOT), the bridge selected is the Cedar Avenue/MN 77 Bridge (known hereafter as the Cedar Ave. Bridge), which spans the Minnesota River. Along with the Minnesota River, the bridge also spans the borders between Bloomington and Eagan as well as Hennepin and Dakota Counties. The Cedar Ave. Bridge consists of two independent but identical northbound and southbound bridges that comprise three traffic lanes and a shoulder, which is open to traffic for Metro Transit buses. The main span of the bridge, spanning the main channel of the Minnesota River, is a tied arch bridge and is the only section under consideration for installation of a bridge health monitoring system. The Cedar Ave. Bridge lacks redundancy in its design, which qualifies it as a fracture critical bridge. Although fracture critical bridges are not inherently less safe than bridges with redundancy in their design, there is an increased risk that undetected flaws may result in collapse or partial collapse of the bridge. After the collapse of the I-35W Bridge, it has become a goal of Mn/DOT to be able to effectively monitor fracture critical bridges, where the failure of one member of the superstructure can result in a bridge collapse. Serving as a major thoroughfare for public commuting to and from the southern suburbs to landmarks like Mall of America, Minneapolis/St. Paul International Airport, and surrounding cities, the Cedar Ave. Bridge is a vital part of Minnesota's infrastructure and a qualifying candidate for installation of a bridge health monitoring system.

### **2.2 Nature of Monitoring**

The length of monitoring required for the Cedar Ave. Bridge is expected to be long term. The bridge is approaching its 30<sup>th</sup> year in operation and bridges of its nature have an average life of seventy five years. Since the bridge will be monitored over a long time span, the data collected over this time period will serve to indicate if fatigue cracks develop, as well as the propagation of such cracks. As such, the data collected can be used as an indicator for possible failure of the bridge's critical members. Therefore, a user defined limit of fatigue crack propagation will serve as an early warning system to be incorporated into the bridge monitoring system. In addition this report focuses on monitoring the development and propagation of fatigue cracks in critical members, whether by monitoring locally to distress or the entire bridge. As the Cedar Ave. Bridge has been in operation for nearly thirty years, the bridge monitoring system will be installed post-construction.

### **2.3 Bridge Type and Components for Monitoring**

The main span of the Cedar Ave. Bridge is a tied arch bridge, which is one of several types of fracture critical steel bridges. The monitoring program will focus solely on the main span and in particular on local fatigue cracks in critical members, so there is little need for data

collection of any general data such as: climate conditions, load, and vehicle counts. Some global displacements or local strains may be monitored as an indicator of overall system behavior. However, it has been determined in discussions with staff from the Mn/DOT Office of Bridges and Structures that the critical members of this bridge are the steel connections, box ties, floor beams, and possibly the cables. Therefore, only steel members need be monitored and monitoring of concrete members can be neglected. As stated previously, the type of failure we are interested in for this report is failure due to fatigue: fatigue in bridges that can lead to crack, development growth, and fracture. After consulting Bridge Health Monitoring and Inspection – A Survey of Methods, it has been determined that the most effective system for monitoring and analyzing the development and propagation of fatigue cracks is using acoustic emission technology. A further explanation of how acoustic emission technology fulfills the requirements of this project can be found in Chapter 3.

## **2.4 Type of Monitoring System**

The monitoring system installed must be portable, since initial testing of critical members may conclude that additional monitoring in alternate locations is required to provide advance warning. The concept of the system being portable also allows for future expansion of the monitoring system. Also, for the purpose of simplicity, a single vendor is desired for all components of the monitoring system including: acoustic emission devices, data logging devices, and communication devices. In regards to communication devices, it is preferred if data can be accessed and analyzed offsite. The Cedar Ave. Bridge was built without any communication devices present that can be used for data transfer. Therefore, wireless communication will be used to access the bridge monitoring data, where either a cell phone or satellite phone will be used. In addition, access to electrical power for the health monitoring device is not available either.

One of the goals of this project is to develop a system which requires a minimum number of visits to the bridge in order to monitor its health. Therefore, any electrical power alternative that requires regular visits for maintenance and replacement (e.g., batteries alone) is not an appropriate alternative. Also, if the batteries lose their charge before being replaced, there will be discontinuities in the data collection. Consequently, solar panels will be used to power the monitoring device. In order to ensure continuous data collection, back up battery power will also be installed.

Because this is a long term monitoring project, the monitoring system must be able to withstand the temperature extremes that can occur in Minnesota. Unless the system is enclosed, it must be able to survive and operate in temperatures as low as 50 degrees Fahrenheit below zero and as high as 120 degrees Fahrenheit. The extreme high temperature is due to heating that occurs on road surfaces during summer months. Therefore, it is most likely that the system will be stored in a protective enclosure.

The technical information (e.g., specifications and performance data) that the monitoring system vendor can provide are also vital in the selection of a vendor. As stated previously, a single vendor for all components of the monitoring is desired. Therefore, the vendor must provide means for data collection, data analysis, and, if needed, software training. For this project, the software needs include sensor calibration and verification, data analysis, and data collection. Since the scope of this project includes the design and layout of the bridge monitoring system, the vendor need not provide these services.

## 3 Monitoring System and Vendor Selection

### 3.1 System and Vendor Selection Methodology

The system and vendor selection process uses the completed Mn/DOT project (Bridge Health Monitoring and Inspection – A Survey of Methods) to generate a list of qualified vendors and monitoring systems that meet the needs of the Cedar Avenue Bridge Project. If the results of the EXCEL file generate multiple suitable vendors, a vendor will be selected based upon prior client experience. This chapter describes the rating of all qualified vendors and their products, while also including justification for the use of acoustic emission (AE) technology for this project, which is selected based upon research of applicable technologies.

### 3.2 Technology Analysis

The overall objective of this project is to implement a monitoring system that will provide advance warning of distress in a fracture critical bridge. Two of the largest failure mechanisms for a fracture critical bridge are fatigue cracking and fracture of welds. Therefore the monitoring technology selected must be able to identify crack initiation, crack propagation, and weld fracture, while also providing warning of potential failure. AE monitoring provides the bulk of the needs for this project in a single device.

AE sensors, depending on their positioning, serve as either a *local* or *global* monitoring device. If specific locations of potential cracking/fracture in the structures are known, AE sensors can be placed *local* to the event source to not only monitor the growth of surface cracks but also internal cracks, which would otherwise be missed upon visual inspection. If used as a *global monitoring device*, AE can be implemented to determine the location of crack initiation and propagation (Grosse 2008). Since AE is a continuous monitoring system, the rate of growth of fatigue cracks can be determined on a continuous basis as opposed to yearly readings from visual inspection (Holford 2001). Another benefit of AE events being recorded on a continuous basis is that the bridge damage is recorded over the entire load history, so that the effect of different loading conditions on the bridge can be determined.

A large benefit of this monitoring technology is that it is a permanent in-situ device, meaning AE provides a means of monitoring the bridge's health without repeated traffic lane closure. While avoiding traffic disruptions is important, the most important goal of this project is to provide safety for the motorists that use the Cedar Avenue Bridge, and AE is capable of providing very early warning of failure. With proper calibration, sensor location, and data interpretation AE can identify the location, type, and severity of a crack event (Grosse 2008).

### 3.3 Suggested Vendors

The analysis of suitable vendors was completed using the EXCEL program developed in a previous Mn/DOT research project (Bridge Health Monitoring and Inspection – A Survey of Methods) and the information documented in Chapter 2 of this report. The results of the EXCEL program analysis can be seen in Table 3.1 below.

The various trials completed in determining the 'best' suitable vendor serve as an attempt to ensure that only vendors capable of a complete system be investigated further. In the EXCEL program, the user can place an emphasis on different monitoring requirements (bridge type, software, nature of monitoring, etc.) by weighting the value of the user's response to the program's questions. The five different program trials also serve as a method for calibrating the program, and ensuring its results are repeatable. Trial 1 is a control run, where the program is run with no emphasis on any monitoring capabilities the vendor can provide. Trial 2 is

completed with emphasis on the nature of monitoring required for this bridge. Trial 3 run is completed with emphasis on the bridge type and monitoring components. Trial 4 is run with an emphasis on the monitoring system type (acoustic emission). Finally, trial 5 is completed, where all responses pertaining to the scope of work for this report have a weight of five. As seen in Table 3.1 below, the results of each trial are fairly reproducible, where Mistras, LifeSpan, and Advitam warrant further investigation.

Since trial 5 incorporates all requirements of this project, its results are deemed the most crucial. As seen in the table, Mistras is a 96% match, Advitam is an 83% match, and LifeSpan is an 83% match to the project’s monitoring needs. ATI, Futurtec and Pinnacle Technologies have a 74% match, while Roctest Ltd and Osmos USA have a 77% match. However, the last five companies listed do not provide their own AE monitoring devices. It is also noted that increasing the weight factor of certain monitoring requirements will generate different results. However, note that Mistras always generated the highest percentile match for all of the conditions considered.

**Table 3.1. Weight Considerations and Results**

Trial 1: Control			
Question Section	Weight	Company	% Match
Nature of Monitoring	1	Mistras	89%
Bridge Type & Monitoring Components	1	Roctest Ltd	84%
Monitoring System Type	1	Osmos USA	84%
		Pinnacle Tech	79%
		LifeSpan	79%
		Futurtec	79%
		ATI	79%
		Advitam	79%
Trial 2: Weight on Nature of Monitoring			
Question Section	Weight	Company	% Match
Nature of Monitoring	5	Mistras	94%
Bridge Type & Monitoring Components	1	Roctest Ltd	91%
Monitoring System Type	1	Osmos USA	91%
		Pinnacle Tech	89%
		LifeSpan	89%
		Futurtec	89%
		ATI	89%
		Advitam	89%

Trial 3: Weight on Bridge Type and Monitoring Components

Question Section	Weight	Company	% Match
Nature of Monitoring	1	Mistras	94%
Bridge Type & Monitoring Components	5	LifeSpan	74%
Monitoring System Type	1	Advitam	74%
		Roctest Ltd	65%
		Osmos USA	65%
		Pinnacle Tech	61%
		Futurtec	61%
		ATI	61%

Trial 4: Weight on Monitoring System Type

Question Section	Weight	Company	% Match
Nature of Monitoring	1	Mistras	83%
Bridge Type & Monitoring Components	1	Roctest Ltd	80%
Monitoring System Type	5	Osmos USA	80%
		Pinnacle Tech	77%
		LifeSpan	77%
		Futurtec	77%
		ATI	77%
		Advitam	77%

Trial 5: Varying Weight Based on Scope of Work

Question	Weight	Company	% Match
Nature of Monitoring:	N/A	Mistras	96%
Monitoring Length	5	LifeSpan	83%
Warning Systems	5	Advitam	83%
Size Scale	1	Roctest Ltd	77%
Installation Type	5	Osmos USA	77%
Bridge Type & Monitoring Components:	N/A	Futurtec	74%
Bridge Type	5	ATI	74%
Fracture Monitoring Type	5	Pinnacle Tech	74%
Crack Growth Monitoring Type	5		
Monitoring System Type	N/A		
Permanent Installation	5		
Single Vendor	5		
Offsite Data Acquisition	1		
Communication Type	1		
Power Type	1		
Temperature Range	1		
Software Capabilities:	N/A		
Sensor Calibration and Checking	1		
Data Analysis	1		
Data Collection	1		
Alarm Thresholds	1		
Offsite Monitoring	1		
Vendor Services:	N/A		
Data Collection	1		
Data Analysis	1		
Software Training	1		

### 3.4 Vendor Product Comparison

All of the information below regarding each of the three qualified vendors can be found in vendor questionnaire response section of the Mn/DOT research project (Bridge Health Monitoring and Inspection – A Survey of Methods). Since all three vendors discussed below provide AE monitoring devices, only the capabilities of each specific vendor is discussed.

Mistras provides a comprehensive AE monitoring system that can be operated using solar power, and can communicate using cellular and Wi-Fi wireless devices. Mistras’ AE device is also capable of withstanding temperature extremes that exceed those for Minnesota’s climate, ranging from -86° F to 158° F. In addition, Mistras’ AE device caters to this project with its ability to be installed both permanently or be portable and be installed post-construction. Mistras currently provides AE monitoring services for multiple clients monitoring the health of bridges. The vendor also provides software for data collection, data processing, data integration, remote monitoring and user defined warning thresholds. Mistras’ SH-II AE device is a complete system, providing all AE monitoring needs for this project.



Advitam devices are being currently used on multiple bridge projects as a means of health monitoring. The AE devices Advitam designs are completely customizable. That is, the device can be designed to withstand a large temperature range, run on solar power, and provide wireless data acquisition. Advitam is also able to customize the monitoring software to each specific bridge, meaning the software is capable of serving as an early warning system. Although, Advitam expresses preference in during construction installation, post-construction installation is available.

LifeSpan's AE device provides the same general monitoring services of Mistras and Advitam. However, the large difference is that LifeSpan provides a website for the user. This website is where all bridge health data will be uploaded for analysis by the user. LifeSpan provides training on how to use the website as well as the hardware and software provided on the website. The website can be used for data handling, alarming features, diagnostics and data presentation. The vendor is also capable of powering an AE device using solar power and also able to provide wireless data transfer. The AE devices LifeSpan provides are able to serve as long-term monitoring devices and can be permanently installed or have portable capabilities, depending on the client's desire. The client can also select if the devices are to be installed pre or post construction.

All three vendors are able to provide a complete AE monitoring system that meets the needs of this project. All three also allow for customization of the product for each specific project. Software and hardware are available from each company for use in data logging, data handling, and early warning. All three vendors are also capable of installing the monitoring devices either pre- or post-construction, depending on the project requirements. The one notable difference is that Mistras specializes in AE monitoring devices, while the remaining two have broader monitoring capabilities. Although LifeSpan indicated in the Mn/DOT research project (Bridge Health Monitoring and Inspection – A Survey of Methods) that the company provides AE monitoring devices, after consulting with a sales representative at LifeSpan it was determined that the AE devices LifeSpan sells are built by Mistras. Therefore, the vendor selection decision should be based upon a rating of vendor client experience of Mistras and Advitam.

### **3.5 Vendor Client Experience**

In order to rate each vendor based upon their client experience, Mistras and Advitam were contacted and a list of references was requested. The list of vendor references was to include only clients using AE devices for similar applications: steel bridge health monitoring. After contacting and inquiring both Mistras and Advitam for references, only Mistras replied and provided a list of references. Despite being contacted multiple times, Advitam never provided the requested references or specifications on their product. Therefore, the vendor suggested for this project is Mistras. Although only Mistras replied with a list of references, each reference was still contacted and requested to fill out a satisfaction survey. A total of eight references were provided and contacted. However, only three replied. The other five references did not respond due to privacy issues related to each respective project. The results of this survey can be seen in the table below. The survey and client responses can be found in the Appendix section of this report.

**Table 3.2. Mistras Client Satisfaction Rating Survey Results**

Question	Client 1	Client 2	Client 3
AE Device Type	Various	Sensor Highway Smart Monitor	Various
AE Application	Civil and Aero	Steel Bridge Fatigue Cracks	Steel Bridge
Monitoring Length	8 Years	2 Years	8 Years
Pre-Monitoring Assistance	10	8	10
Maintenance	8	8	10
Meeting Monitoring Needs	10	7	10
Software Satisfaction	10	7	10
Mistras Overall	10	8	10
Mistras Device Overall	10	7	10
Percent Satisfaction	97%	75%	100%

Combined % Satisfaction 91%

## 4 System Design

Chapter 4 details the design of the monitoring system for the Cedar Ave. Bridge. As required by the scope of work the system design will include: the number and placement of AE sensors, the location and number of data logging equipment, detail of power supply, detail of wireless data communication devices, and how to secure all equipment to the bridge. The system design explores multiple alternative sensor arrays: one focused upon global monitoring of the bridge's arch tie box girders (box girder) and the other focusing on local monitoring of the box girders. In order to determine the number of AE sensors required for local monitoring of the bridge, a finite element model is developed and high stress concentration areas ("hot spots") are identified as areas where AE sensors need be installed. Also, the scope requires that the report will include identification and classification of possible distress types that will be observed using AE devices. In addition, the system design will include a link between field data and different distress events (event characterization) with each different distress event having a specific defined protocol response. The final requirement of the system design is that a schedule of inspection and maintenance of the monitoring system be developed for the remaining life of the bridge.

### 4.1 Finite Element Model Formulation for Local Monitoring

The reason for developing a finite element model is to determine possible locations of future distress. Since annual, visual inspection of the Cedar Ave. Bridge indicates that the bridge is healthy (no visual cracks, little corrosion, etc.), location of potential flaws must be determined in an alternate method. With the location of potential flaws determined, local monitoring can be achieved with AE sensors being installed local to high stress concentration areas. The location of high stress concentration areas is determined using multiple finite element models developed using the software, SAP2000. The first of these models is a frame element, global model. The global model details all members of the Cedar Ave. Bridge at span 12. In order to validate the accuracy of the global model the maximum dead load moment, shear, and axial force in each member determined by the model is compared to each respective member force presented in the bridge plans. Once the global model is validated, an analysis of bridge response due to both live load and dead load is run. From this analysis the most severe sections and connections are selected for local modeling. For this report, most severe is defined as a section or connection, where the combination of moment, shear, and axial forces are the greatest. Each severe location will have its own local, 3D, shell model developed. The forces input into the local model are the forces at each location determined by the global model. From the local model, high stress concentration areas are identified and indicated as suitable locations for installation of AE sensors. Approximately 10% of the total allocation of time for this project was spent designing and analyzing these finite element models. This approximation is based upon a 50% assistantship for sixteen months.

### 4.2 Global Finite Element Model Calibration

As specified above, the member forces generated in the global finite element model are compared to the plan forces in each member to ensure that the global model is generating accurate results. Table 4.1 through Table 4.4, seen below, displays the results of this comparison. The nomenclature for identifying each member is maintained from the bridge plans. Since span 12 is symmetric about the center of the span, only half of the span is included in the tables. The joint identification runs from 0 to 6, with 0 being the northernmost joint and 6

being the center of the span. In Table 4.1 through Table 4.4 and in the bridge plans, “L” indicates a lower joint (girder elevation), and “U” indicates an upper joint (rib elevation), as seen in Figure 4.1 below. As can be seen in the tables, the model and plan dead load values are similar, and therefore the global model is accurate. Please note that for the arch rib all axial forces are compression.

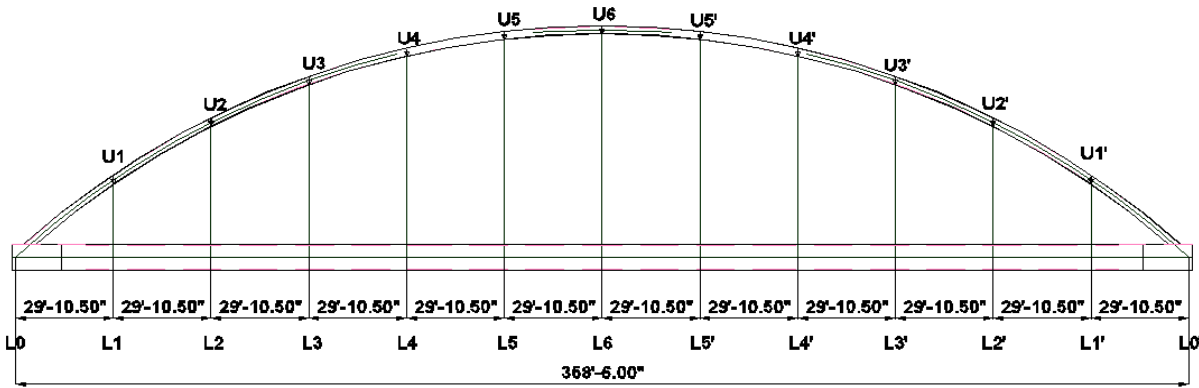


Figure 4.1. Profile View of Cedar Ave. Bridge

Table 4.1. Arch Rib Subjected to Dead Load

Section	Plan		FEM	
	M <sub>max</sub> (ft-kips)	P <sub>max</sub> (kips)	M <sub>max</sub> (ft-kips)	P <sub>max</sub> (kips)
LO-U1	435	1920	493	1858
U1-U2	410	1809	501	1740
U2-U3	499	1709	503	1650
U3-U4	482	1632	541	1577
U4-U5	505	1579	576	1527
U5-U6	503	1550	576	1498

Table 4.2. Floor Beam Subjected to Dead Load

Member	Plan		FEM	
	M <sub>max</sub> (ft-kips)	R <sub>max</sub> (kips)	M <sub>max</sub> (ft-kips)	R <sub>max</sub> (kips)
End Floorbeam	1137	71.3	1200	83.1
Int. Floorbeam	3011	190.0	2465	158.1

**Table 4.3. Hangers Subjected to Dead Load**

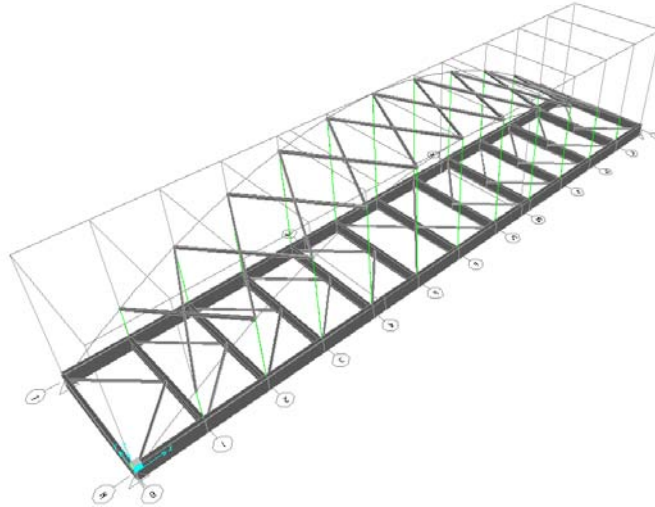
	Plan	FEM
Member	$P_{max}$ (kips)	$P_{max}$ (kips)
L1-U1	209	191
L2-U2	209	173
L3-U3	209	173
L4-U4	209	174
L5-U5	209	185
L6-U6	209	207

**Table 4.4. Arch Tie Box Girder Subjected to Dead Load**

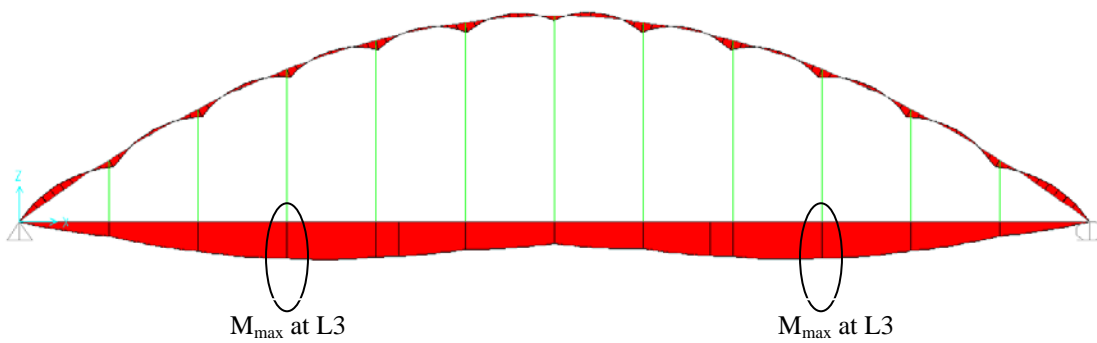
	Plan	FEM
Joint	$P_{max}$ (kips)	$P_{max}$ (kips)
L0	1549	1494
L1	1549	1494
L2	1549	1494
L3	1549	1494
L4	1549	1494
L5	1549	1494
L6	1549	1494

### 4.3 Global Finite Element Model Development and Results

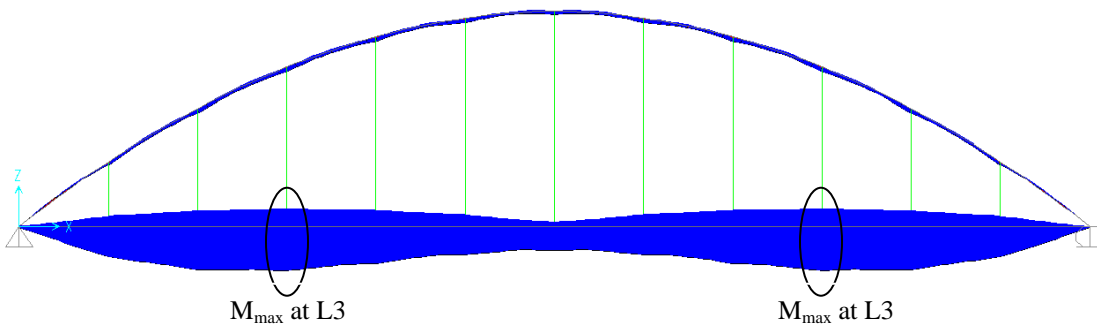
Seen below in Figure 4.2 is an isometric view of the Cedar Ave. Bridge's global, frame element model developed for this analysis. All frame elements are assumed to have simple connections, meaning either fully fixed, pinned, or roller at all joints, determined by viewing the bridge plan. In order to accurately account for the self weight of the bridge's steel, all sections were developed using SAP2000's section designer, according to the bridge plan provided by Mn/DOT. The bridge's deck, stringers and surface weight are accounted for with point loads located at location of stringer to floor beam connections. The stringers and deck were not modeled in the global model, but were assumed to provide additional rigidity to the bridge, which is why the loads are applied as vertical point loads. According to the results of the global, dead load only finite element model, the most severe location of the box girder is joint L3 and its symmetric counterpart joint L3', as seen in Figure 4.3. In addition, when the global model is analyzed with an AASHTO HS 20 (MS 18) truck in any lane orientation, it is always one of the typical L3 joints that will see the largest local forces. This can be seen in Figure 4.4, which displays the range of moments due to combined live load and dead load. Since the L3 joint experiences the largest forces when combining dead load and live load, these global combined load forces will be input into the local model of the box girder. Since the bridge is symmetric about the center of its span and about the centerline of the roadway, only one typical L3 connection is analyzed in the local model.



**Figure 4.2. Isometric View of Cedar Ave. Bridge**



**Figure 4.3. Moment Distribution in Global SAP2000 Model for Dead Load**



**Figure 4.4. Moment Distribution in Global SAP2000 Model for Combined Load**

#### 4.4 Local Finite Element Model Development and Results

The L3 joint consists of floor beam number three to box girder connection. Also, at L3 is the connection of cable hanger L3-U3 to the box girder. The box girder web and flange, diaphragm, and hanger plate are all modeled as shell elements. The shear in the bolted floor beam to box girder web connection is modeled as an even distribution of point forces at each bolt location. The shear in the box girder, where the section cuts are made for the local model are also modeled as an even distribution of point forces, located at each node. The hanger tensile force is modeled as two point loads each located on the hanger plate. The axial force in the box girder is evenly distributed at each nodal location at the section cut, where the total sum is equal to the total axial force. The moment in the box girder for the local model is applied through a distribution of forces located at each section cut nodal location to create a couple of forces equal to the moment in the box girder from the global model. These coupled forces are distributed in a manner such that the normal stress from the distribution of forces is equal to the normal stress due to the moment in the box girder.

Below are the visual results of the local model at connection L3. Both figures display maximum value Von Mises stresses, which is SAP2000's method for the combination of multi-axial states of stresses. Please note that the dark blue color indicates the greatest stress in the system, while the color purple indicates the smallest stress. As can be seen from each of the figures below, the location of the largest stress occurs where the hanger plate and diaphragm connect to the box web. Therefore this is the most suitable location for the installation of AE sensors for local monitoring.

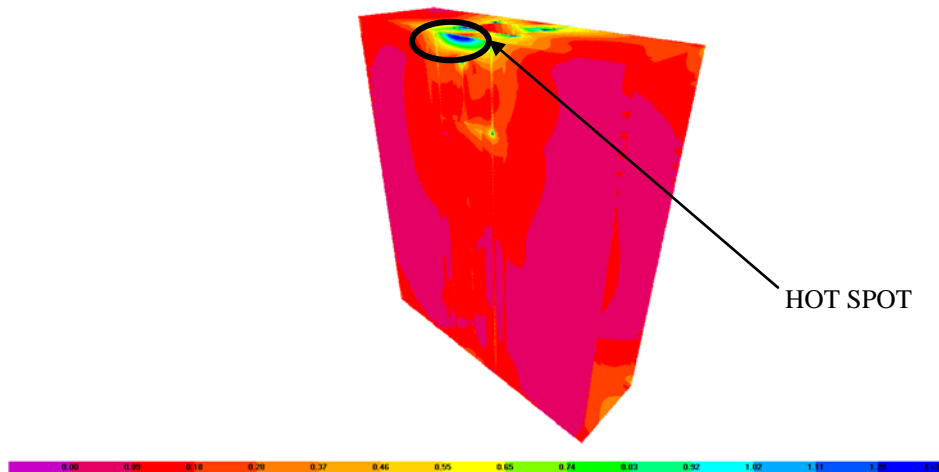
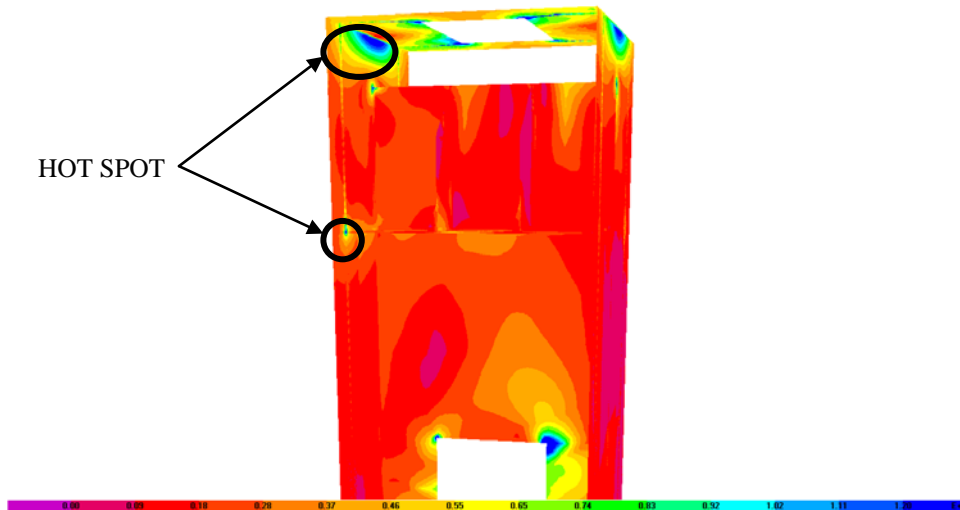


Figure 4.5. 3D SAP2000 Model of L3 Connection (Box Girder Exterior)



**Figure 4.6. 3D SAP2000 Model of L3 Connection (Box Girder Interior)**

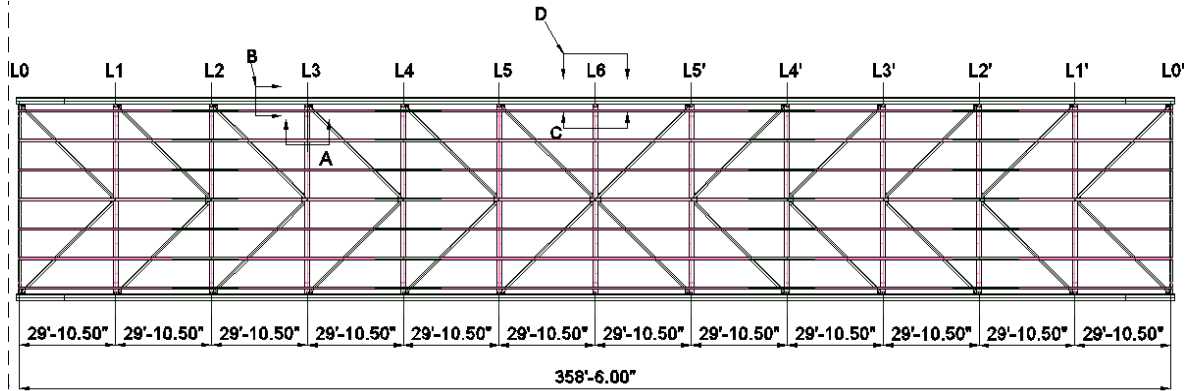
#### **4.5 System Selection**

Chapter 3 of this report details the selection process of a specific vendor for an AE monitoring system. In this chapter, Mistras Group was selected as the vendor for this project. However, Mistras Group provides multiple alternative monitoring devices. In application for this report there are two alternatives considered. Each of the alternatives is Sensor Highway II Systems (SH-II) that differ solely in where the monitoring data is stored. The first of the two SH-II alternatives is the SH-II N, where the N indicates networked. This system is designed to communicate wirelessly with a base station computer: a PC with a user interface used to monitor the bridge manually. The second alternative is the SH-II SRM, a standalone device where all monitoring and AE signal analysis is done by the device, not by the user. To alert the user of bridge distress the SH-II SRM has alarm capabilities with the notification being sent via e-mail to the user. The user of the device may still access the AE data through the internet or with a base computer (Mistras Group, 2009). The cost of both SH-II systems is considered in Chapter 6 of this report.

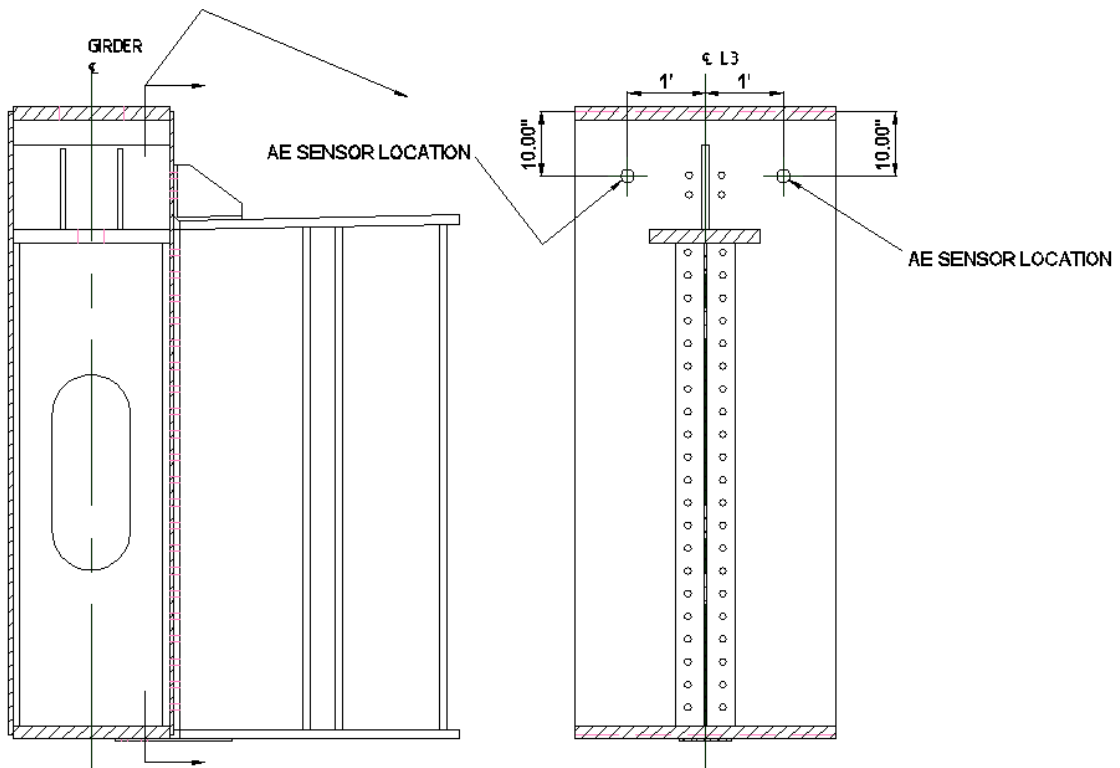
#### **4.6 System Installation for Local Monitoring**

As indicated in the local FEM results section of this chapter, the location requiring installation of AE sensor devices for local monitoring is joint L3. Figures 4.7 through 4.10 detail the exact location of suggested AE sensor installation. Specifically Figures 4.8 through 4.10 detail various sensor arrays inside the box girder. The monitoring capabilities of each of the three possible sensor arrays are explained below. Figure 4.11 details the installation location of the selected SH-II device module. Figure 4.12 shows the location and mounting of a solar panel to power the entire SH-II monitoring system.

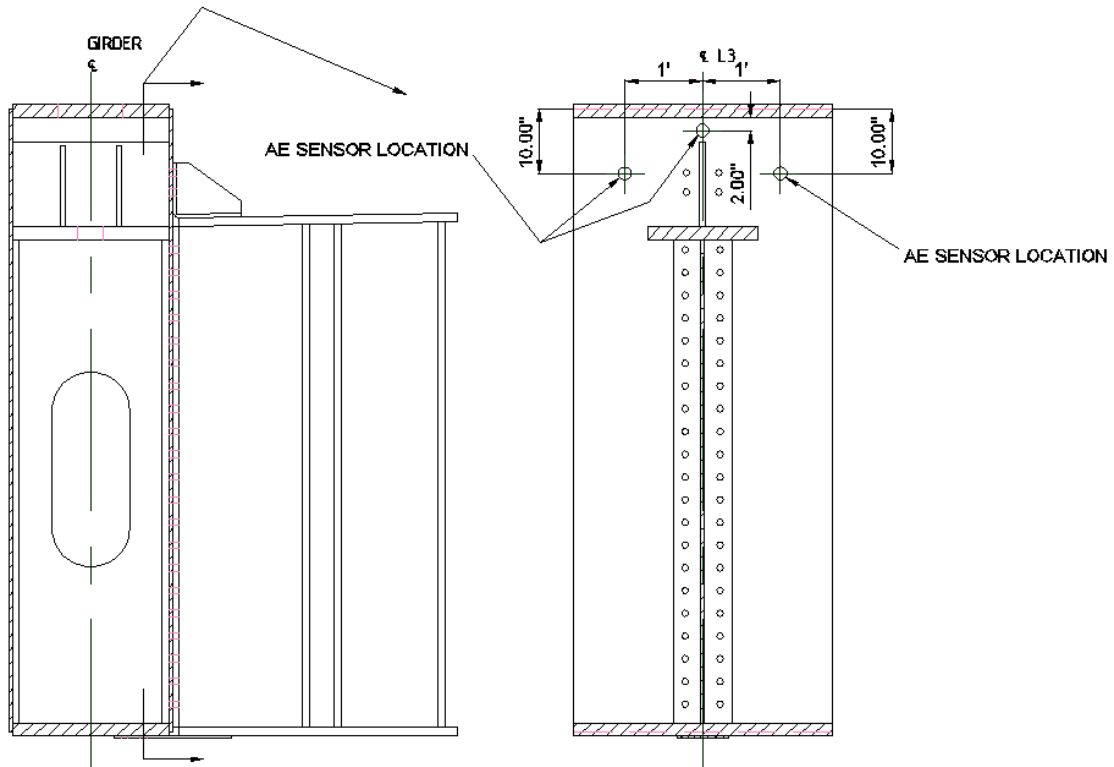




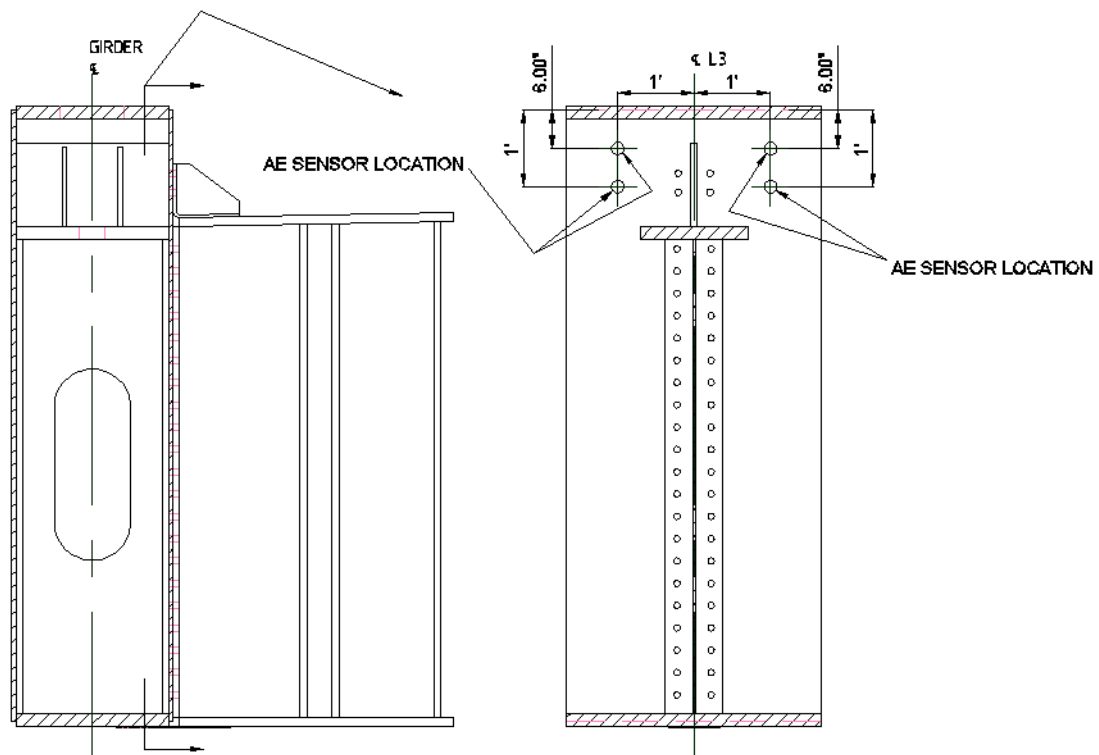
**Figure 4.7. Plan View of Cedar Ave. Bridge**



**Figure 4.8. Section B (Alternative 1 AE Sensor Location)**



**Figure 4.9. Section B (Alternative 2 AE Sensor Location)**



**Figure 4.10. Section B (Alternative 3 AE Sensor Location)**

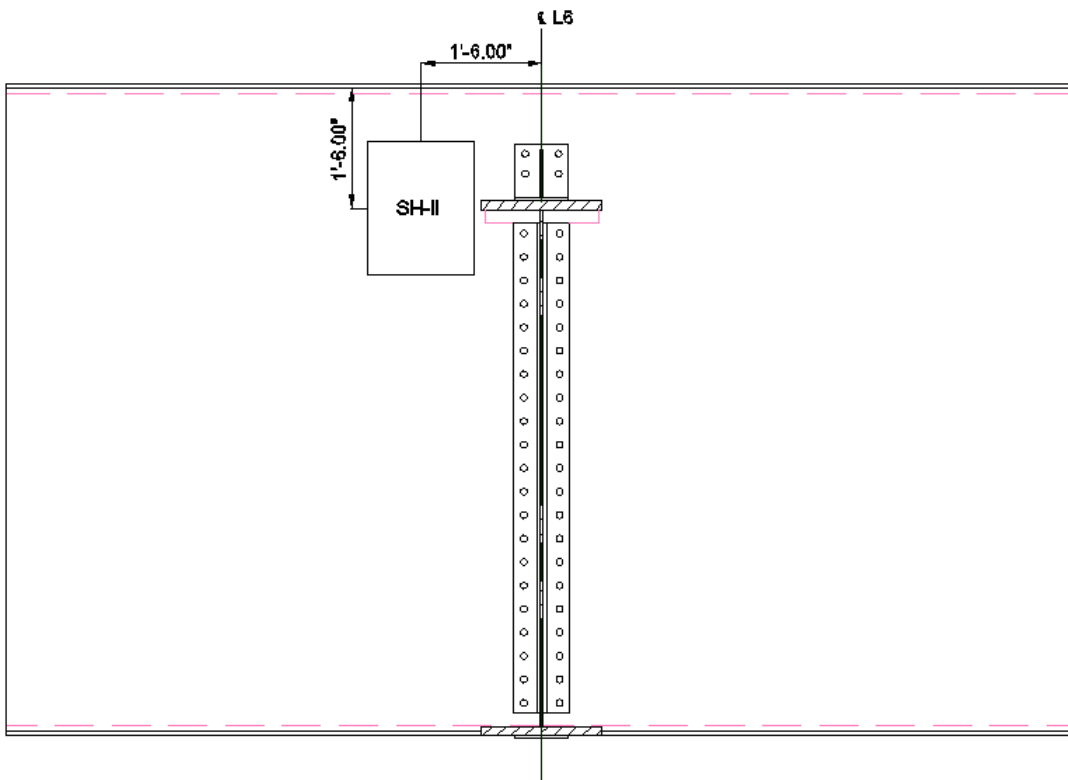


Figure 4.11. Section C (SH-II Module Location)

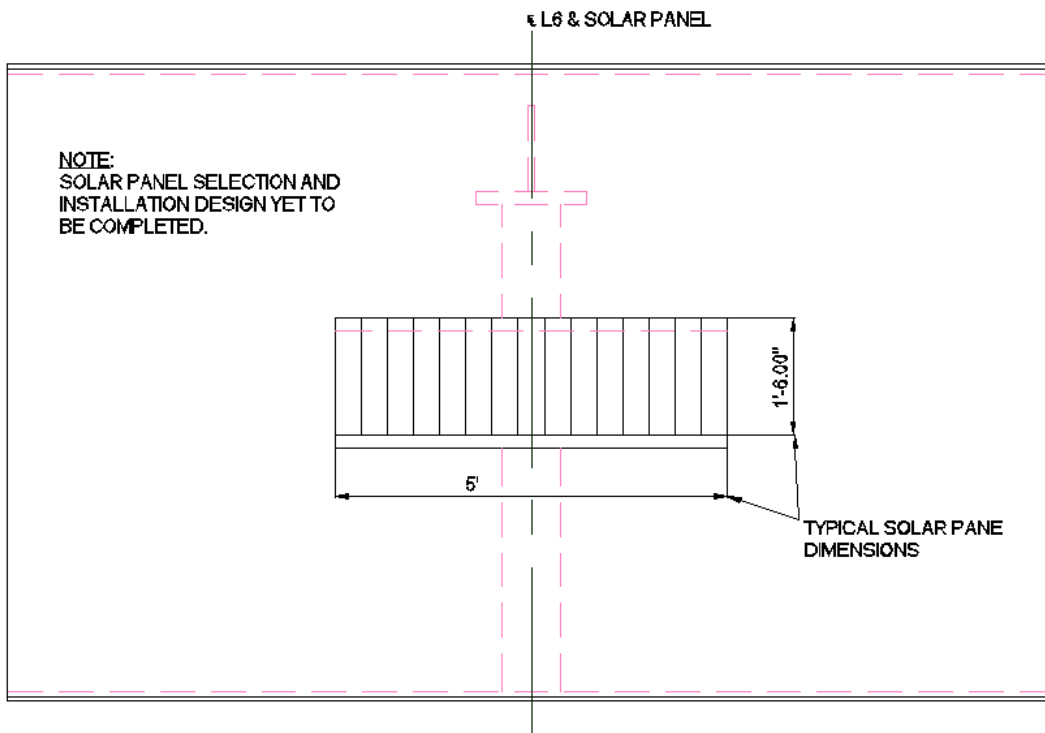


Figure 4.12. Section D (Solar Panel Installation)

Initially, installing the sensors inside the box girder was believed difficult due to issues of serviceability and access; it has been determined that installation inside the box girder is possible. The different alternatives are intended to help improve source localization and characterization, discussed in Chapter 5. Chapter 5 explains that a two sensor array is able to achieve linear signal localization, a three sensor array is able to achieve signal localization in two dimensions, and a four sensor array is able to locate a signal source in three dimensions (i.e. length, height, and depth). The cost of each of these three different alternatives is detailed in Chapter 6. It is important to note that the design detailed in the figures above is typical for both northbound and southbound bridges, and that at least two sets of SH-II systems and sensors must be purchased: one for each bridge. In addition, it is likely that one SH-II system must be purchased for each box girder.

Each of the sensors is to be magnetically mounted to the bridge, and to communicate signals to the SH-II module using coaxial cables. The SH-II module is to be mounted in a similar manner to the sensors. It is best if the SH-II module be mounted beneath the bridge deck or inside the box girder to avoid precipitation. Contained in the housing of the SH-II module is a wireless communication device, used to relay monitoring data to the user, therefore a detail of wireless communication devices is not required. The complete installation procedure can be found in Chapter 6.

As seen in Figure 4.8 there are two AE sensors located at each typical L3 connection. At least two sensors are required at each location (more are optimal) in order to triangulate the AE signal source location using even the simplest methods (Pullin, Baxter, Eaton, Holford, Evans, 2010). Due to the location of hanger plate welds, and girder web to girder flange weld it is optimal if the AE sensors are installed inside the girder, since it is easiest to determine the AE signal source location and signal characterization if the source and sensors lie in the same plane. If installation inside the girder were not a possible alternative, there are methods for determining signal source and characterization even through thick plates. The methods for AE signal source location determination and signal characterization are explained in Chapter 5 of this report.

#### **4.7 System Installation for Global Monitoring**

The concern of the bridge's health is in the development and propagation of cracks due to fatigue. Since fatigue cracks depend not only on loading, but also connection details, it may be that fatigue cracks first begin to develop in a location other than L3. In addition, the local high stresses at L3 do not differ much from L2 and L4 locations, which can be seen in the moment distribution of Figure 4.4. Not only do the L2 and L4 locations have similar stresses, the connection at these locations is typical to the connection at L3. For these reasons, it may be beneficial to focus not just on local monitoring at L3, and instead initially rely on the global monitoring capabilities of AE. However, the details of sensors installed local to distress areas (the previous section) may be used as a guide for installation in the future if cracks do develop.

As discussed in the following chapter, the linear location of a distress event can be determined with only two sensors receiving the distress signal. Therefore, the most economical method for global monitoring of the bridge is a linear array of AE sensors. For the Cedar Ave. Bridge the sensors are to be installed either on the interior or exterior of each box girder in a linear array. The spacing between each sensor depends upon how well the AE signals attenuate through the box girder. This spacing cannot be determined until field tests on the bridge are completed. These tests require that a signal be produced by breaking a pencil on the box girder and the same signal be received by a hand held AE sensor; the procedure of which is detailed in

Chapter 6 of this report. The hand held sensor should initially be placed local to where the pencil is broken. Then the spacing between the pencil break and the sensor is increased until the signal is too weak to locate and characterize. Since determining the sensor spacing involves trial and error, the complete system should not be purchased until after these initial field tests are completed.

If the global monitoring alternative is selected for installation on the Cedar Ave. Bridge, the sensors should be attached magnetically. This allows the user to alter the sensor array in the future if cracks begin to form and local monitoring becomes a priority. Also, please note that this alternative requires installation of a linear array of sensors on each of the four box girders (two on each bridge), which may require more than one SH-II system per bridge. Pricing for both SH-II module types and sensors is detailed in Chapter 6.

#### **4.8 Distress Response**

The necessity of response to an AE event is determined by the severity of the AE event. Initially, since the Cedar Ave. Bridge has no visible fatigue cracks, it will be important determine if the AE events classified as being due to cracks are micro-cracks (not visible), macro-cracks (visible), or monitoring error. The most applicable method to differentiate between these possibilities is visual inspection. Therefore, once AE events due to crack development and propagation begin being recorded by the AE sensors, bridge inspectors should visually inspect the location of these events during its routine visual inspection of the bridge. Once cracks begin to develop on the macro scale more attention need be given to the monitoring system. If the global monitoring alternative is selected for this project, once cracks begin to develop, Mn/DOT should consider installing additional monitoring equipment local to the crack. Specifically, the installation of strain gauges located across the crack tip can assist in monitoring the propagation of macro sized cracks. Installing strain gauges local to the crack tip provides the user with a check of the AE sensor recordings of crack propagation. Strain is related to stress, where a critical stress value leads to crack propagation, which should produce a corresponding AE event. However, additional instrumentation is not necessary and depends upon the accuracy of the AE sensors. Once macro-cracks develop and propagate, it will be at the discretion of Mn/DOT to decide if the cracks are reaching critical lengths, and what response need be taken.

#### **4.9 System Inspection and Maintenance**

The bridge monitoring system is to be inspected regularly on the same date that bridge inspectors visually inspect the Cedar Ave. Bridge. In order to ensure that the sensors are operating and recording signals accurately, an AE signal will be produced local to each sensor, using the same pencil breaking method discussed in Chapter 6. The person(s) conducting AE monitoring of the Cedar Ave. Bridge will access the resulting sensor data on site using a laptop computer. If a sensor does not record an AE signal when one is produced, then the sensor or cable connecting the sensor to the module need be replaced. If a sensor records an AE signal that does not correspond to the signal produced, then the sensor need be recalibrated, using similar techniques to the calibration method described in Chapter 6 or if recalibration does not eliminate the error the sensor must be replaced. The process of producing an AE signal and inspecting the sensor readings must be repeated at all AE sensor locations in each of the four box girders. This inspection testing method is described in further detail in Chapter 6 of this report.

## 5 Acoustic Emission Monitoring Capabilities

Two of the most important results from AE monitoring data are source location determination and signal characterization. This chapter of the report details different methods for locating and characterizing an AE signal. Although both SH-II systems in consideration for the Cedar Ave. Bridge are capable of being fully automated (software defined methods of signal source location and signal characterization), the user may need to alter the software algorithms for source localization and characterization if the results from the data are not reasonable.

### 5.1 AE Source Location

The simplest method for the determination of source location is based upon time of arrival (TOA). Two simplifying assumptions are made for TOA calculations: the wave speed remains constant and the path from the source to the sensor is direct (Pullin, Baxter, Eaton, Holford, Evans, 2010). The equation is as follows:

$$R = \frac{1}{2} \frac{D^2 - \Delta t^2 V^2}{\Delta t V + D \cos \theta}$$

This is an equation for a hyperbola, where R is the hyperbola radius that passes through the location of the source. However, the source could lie anywhere on the hyperbola's path. If a third sensor is added to the sensor array two equations for a hyperbola are solved simultaneously and the source location can be pinpointed more precisely. In addition, a fourth sensor receiving a signal allows the user to determine the location of the source in three dimensions. In short, this means two sensors provide linear signal locations, three sensors provide planar signal locations, and four sensors provide three dimensional signal locations (Miller, Hill 2005).

Another method is the novel mapping approach or Delta-T approach. This method is similar to TOA, but instead of using time difference this approach uses energy difference and wave velocity. Mapping is completed by first determining an area of interest using a finite element model. Then an array of sensors is attached around the area of interest, and a grid is developed of sensor locations. Artificial AE events are created to average change in energy results at each sensor in order to eliminate false signals. Finally, a map is generated using difference in energy calculates with a similar algebraic expression as the TOA method. Some advantages to this method are that the mapping of source location is independent of the source path. This means that changing plate thickness or discontinuities will not alter the results of determining source location (Pullin, Baxter, Eaton, Holford, Evans, 2010).

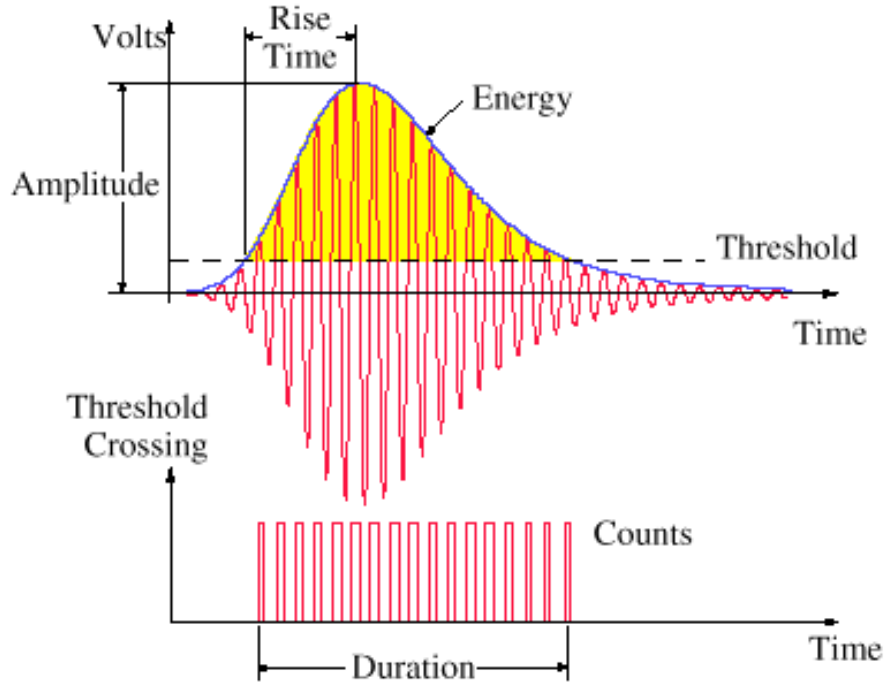
As discussed previously, it is best if the sensors are located on the same plane as where cracking is expected to occur. One reason for this is that arrival time, wave strength, and wave frequency can be altered in the presence of thick plates. The plates in the box girder range in thickness from ½" thick to 2" thick. For this reason it may be necessary to use the application of Lamb Modes to determine the location of an AE signal source. This method requires some manual operation as the time of arrival and source location determination must be related to developed tables to determine the most likely location of the signal in the plate. Several of these tables have been developed that correspond to different sensor arrays where at least four sensors must be local to the AE event (Hamstad, 2010).

## 5.2 AE Signal Characterization

A second powerful tool with AE monitoring is signal characterization. There are many different methods for signal characterization, and each are based upon different AE parameters. As stated in the signal source location section, both SH-II systems being considered are fully automated and have signal characterization capabilities. However, it is important as a user to understand the physical meaning of each AE event.

In structural steel monitoring applications there is one signal characterization that is independent of AE parameters and sensor arrays: background noise. Background noise in a bridge monitoring application will be due to structural dynamics, which transmits AE signals in the range of 0.1Hz to 100Hz (Williams, 1980). In order to eliminate receiving background noise in AE data acquisition, a lower bound threshold will be present where any signal below a user defined signal voltage or signal in the frequency range of 0.1Hz to 100 Hz will be ignored by the AE sensor. Additional background noise in the Cedar Ave. Bridge could be due to fretting, where bolted connections rub against one another and produce AE events. A method for eliminating this type of background noise is placing an AE sensor local to the fretting bolt, and then all AE signals this sensor receives will be ignored by sensors located at other areas of interest (Miller, Hill 2005). In addition, simple signal characterization methods can determine the difference between fretting, background noise, and cracking.

The most important aspect of signal characterization is AE source type. The signal type is determined through interpreting the waveform data received by the AE sensor. As described in the previous paragraph, the first step in this process is eliminating unwanted signals. In regards to AE signal characterization, there are several different methods to interpret the waveform data. Most methods are based upon simple waveform parameters such as: signal amplitude, event energy, signal count, signal rise time, and signal duration. Some of the simple waveform parameters are self explanatory. Signal count is number of AE events that have amplitude greater than the lower bound threshold that are counted for single signal duration. Signal duration is the length of time from the first signal count to the final count signal. Another simple waveform parameter is rise time, which is the length of time from the first signal count to the signal count with the maximum amplitude. Corresponding to rise time is decay time, which is the time from the maximum amplitude count to the final count of the signal duration (Miller, Hill 2005). Below is a schematic representation of a typical AE event (Huang, Jiang, Liaw, 1998).



**Figure 5.1. Definition of Acoustic Emission Parameters**

A correlation between these simple parameters and the stress intensity factor has been developed, which is as follows.

$$N \sim K^n$$

In this expression, n ranges from two to ten, 'N' is the total number of counts, and 'K' is the stress intensity factor, which is a material parameter. The correlation between event counts and the stress intensity factor, which is a material property, is developed with the idea that a larger (more severe) AE event will have more counts before it decays below the threshold level and large AE events correspond to large crack propagation. An additional correlation between waveform parameters and crack propagation has also been developed, and can be seen below.

$$\frac{dN}{dc} \sim \frac{da}{dc}$$

This expression is for the fatigue crack propagation rate, where 'N' is the total number of counts, 'a' is the crack size, and 'c' is the number of cycles. This correlation is what connects simple waveform parameters to fracture mechanics and therefore makes it a valuable tool in a monitoring application.

An energy approach can be considered more beneficial in relating AE signals to distress than the methods already described. The electrical energy read by the AE sensor is directly related to the release of mechanical energy of the system due to some deformation. As seen from Figure 5.16, the electrical energy of the signal is equal to the area under the curve and above the threshold, and is defined by the following equations.



$$U = \frac{1}{R} \int_0^{\infty} V^2(t) dt$$

$$V = V_0 e^{(-Bt) \sin(\omega t)}$$

In these equations,  $V$  is the output potential in volts,  $V_0$  is the initial signal amplitude,  $B$  is the decay constant,  $w$  is the angular frequency, and  $R$  is the electrical resistance in ohms. As stated previously, this expression can be compared to the system's loss of potential energy due to crack growth. In order to relate the release of energy to the magnitude of crack growth a fracture mechanics model of the distress region must be developed.

In application of monitoring steel structures, most AE signals are due to plastic deformation and yielding. Once the signal type is identified as plastic deformation, which is analogous to crack growth, the signal must then be correlated to the severity of the crack growth. This process involves a fracture mechanics analysis of the distress region. As stated above the hit count,  $N$  is directly related to the stress intensity factor,  $K$ . However the value of stress intensity factor depends on the geometry and loading conditions of the system. Therefore, in order to relate a signal event to a specific crack event there must be an understanding of the region local to the event. With an understanding of the geometry and loading conditions of the region local to the AE event, the user can determine if the  $K$  value equated from equation above exceeds a critical value of  $K$  that is determined analytically using fracture mechanics. However this methodology is extremely complicated, given the complicated geometry of the connections, and may not be applicable for this project. Instead of trying to determine the severity of the crack and crack propagation, the user should focus on characterizing the signal types using simple waveform parameters.

There is a learning curve in AE monitoring associated with the appropriate use of simple waveform parameters to relate the AE event to a corresponding distress type. A majority of the learning curve is in sensor calibration. In order to understand if an AE signal is due to crack development, crack propagation, fretting, or background noise, it is necessary to monitor the bridge for a period prior to defining all AE signal types. After a period of receiving signals from various AE events on the Cedar Ave. Bridge the user can develop a method for separating the signal from bridge distress events (cracks, corrosion) from signals due to fretting, background noise, and an existing crack opening and closing. A good method for differentiating between different signal types is plotting the results of the signals using different simple parameters. For example, create a plot of signal amplitude versus signal rise time. From this plot determine if certain signal types cluster together or if all are scattered. If the different signal types cluster together, then this plot can be used in the future to differentiate between different signal types. If the signals are scattered, then attempt a plot using different AE signal parameters. This process involves trial and error, but is very beneficial given the complexity of AE signal characterization. Once the user determines what AE parameters characterize different AE signal events, the system can be set to monitor the bridge automatically (Miller, Hill 2005).

## 6 Implementation Plan

Chapter 6 contains the implementation plan for the monitoring system. This implementation plan includes system pricing, installation schedule, installation procedure, initial testing and verification and a maintenance plan for the equipment. This information is summarized in the sections below, and repeated in plan drawings, found in Appendix B of this report. The system pricing section of Chapter 6 is based upon the quote provided by Mistras, which is located in Appendix B

### 6.1 System Pricing

The price of the monitoring system is variable and depends upon the yet to be determined sensor spacing. Once determined, the sensor spacing will dictate the total cost of the monitoring system. In this report, the system pricing is presented as a sixteen channel, SH-II unit price and the final price can be considered in terms of multiples of the 16-channel system. Below, there is an abbreviated version of the cost breakdown, highlighting the costs pertinent to this project. Appendix C contains the entire cost breakdown provided by Mistras Group.

**Table 6.1. System Pricing Breakdown**

Feature	SH-II-N Unit Price	SH-II-SRM Unit Price
16 Channel System Module	\$11,170.00*	\$10,791.00*
Software	\$2,199.00	\$2,199.00
BaseStation Outdoor (Optional)	\$6,610.00**	N/A
Remote Monitoring Setup	\$2,625.00	\$2,625.00
16 Sensors (incl. 5 meter cable)	\$8,832.00*	\$8,832.00*
1,600 ft of lead cable	\$1,600.00	\$1,600.00
Remote Monitoring Maintenance (Annual)	\$1,050.00	\$1,050.00
Wi-Fi Capability	\$415.00	\$415.00
Solar Panel Kit	\$9,990.00**	\$9,990.00**
Initial Cost	<u>\$36,831.00</u>	<u>\$36,452.00</u>
Optional Cost	<u>\$6,610.00</u>	<u>\$0.00</u>
Annual Cost	<u>\$1,050.00</u>	<u>\$1,050.00</u>
Total Cost	<u>\$44,491.00</u>	<u>\$37,502.00</u>

In Table 6.1 above, features without an asterisk are base cost for the system and are not a function of the number of sixteen channel systems purchase, features with one asterisk indicate unit system cost (i.e., purchase of two sixteen channel systems requires the purchase of two system modules and two sets of sixteen sensors), and features with two asterisks are determined by the demand of all SH-II systems. Additional solar panel kits may be required if the electricity demand of all SH-II systems exceeds the output of one solar panel kit. All solar panels installed must provide either 110/220 VAC or 9-28 VDC power, and each module consumes 30 watts of power. The solar panel kit priced in the table above includes four 130 watt solar panels for a

total of 520 watts of power per solar panel kit. In addition, the kit includes four 110 Ah batteries that provide four days of battery backup. Please note, the BaseStation option serves up to 16 SH-II-N systems. Therefore, if more than 16 SH-II-N systems are purchased a second BaseStation is required.

Each set of sixteen sensors comes with 5 meters of coaxial cable to connect the sensor to the module. However, the Cedar Ave. Bridge will require the purchase of approximately 1,600 feet of additional coaxial cable. The BaseStation option, which is available for the SH-II-N, is a computer that remains on site for the purpose of storing, evaluating, and communicating AE data. The SH-II-SRM system is an online monitoring system, accompanied by a secured website, used to store and analyze data. The SH-II-SRM system is capable of storing data for 999 days. The pricing for a variety of sensor spacing options is detailed in the implementation plan sheets, which can be found in Appendix B, Sheet 5.

## **6.2 Installation Schedule**

The installation schedule is included in Appendix B.

## **6.3 Installation Procedure**

The installation procedure is described in Appendix B.

## **6.4 Initial Testing and Verification**

Initial testing and verification is discussed in Appendix B.

## **6.5 Maintenance Plan**

The maintenance plan is provided in Appendix B.

## **7 Summary, Conclusions and Recommendations**

### **7.1 Summary and Conclusions**

Bridge health monitoring is an effective technique for managing an aging bridge infrastructure, especially for fracture critical bridges. This report documents a study in which the methodology developed in a previous Mn/DOT report was used to investigate, select, and design a bridge health monitoring system for the Cedar Avenue Bridge. Due to its tied arch construction, with steel box girders serving as tension ties, the Cedar Avenue Bridge in Burnsville, Minnesota is a fracture critical bridge, and it was selected as the subject of this study. An investigation of monitoring needs for the Cedar Avenue Bridge was undertaken, and technical literature was reviewed with the goal of determining the most applicable monitoring technology that is commercially available to fulfill the required bridge monitoring needs. The authors determined that acoustic emission is the most effective of the monitoring technologies that are commercially available to identify the initiation and propagation of fatigue cracks in steel members. Other technologies are capable of monitoring fatigue cracks, but only acoustic emission can provide the turn-key, stand-alone capabilities that are desired for this monitoring application.

Once acoustic emission technology was selected, the authors identified a vendor and a complete monitoring system using a computer-based program developed in the aforementioned Mn/DOT report. The selected system of monitoring equipment is proposed to the Mn/DOT for purchase. The study also reviewed multiple alternatives for monitoring scales, scopes, locations, and capabilities, with global monitoring of the most critical members and connections of the bridge as the authors' recommendation. A procedure for installation of the suggested bridge health monitoring system follows the authors' recommendations and is applicable to any of the monitoring alternatives presented in this report.

### **7.2 Recommendations**

With the knowledge that acoustic emission technology provides the most suitable and applicable monitoring capabilities for this project, it is the recommendation of the authors that Mistras Group be used as the commercial manufacturer of all acoustic emission devices required for this project. This recommendation is based upon the results of the EXCEL computer based program applied in Chapter 3 of this report, as well as the customer satisfaction surveys, both which are documented in Chapter 3.

As discussed in Chapter 4 and Chapter 5 of this report, the location for installation of acoustic emission sensors depends upon the desired scope of monitoring. Since monitoring of the Cedar Avenue Bridge will be coupled with visual inspection, the authors recommend that linear localization of signal source is sufficient for the monitoring needs of the Cedar Avenue Bridge. Linear source localization can be achieved with a linear array of acoustic emission sensors. However, since the attenuation of acoustic emission signals through the fracture critical members of the bridge is not known, the linear spacing of the acoustic emission sensors cannot be recommended at this time. Since the linear spacing is unknown, it is the recommendation of the authors that initially a single SH-II system, packaged with 16 sensors, be purchased from Mistras Group. A single set of 16 sensors will allow the monitoring device user to determine optimal sensor spacing through a series of 'pencil break' tests, as discussed in Appendix C. After these initial tests, the authors recommend that a complete system be purchased which is capable of monitoring the girders in both the northbound and southbound Cedar Avenue Bridges.

With a potential increase in the scale of monitoring on the Cedar Avenue Bridge, an alternative power source must be determined. One SH-II system with 16 sensors requires four solar panels and four batteries to power it. Therefore, an increase in the scale of monitoring (more SH-II systems) will lead to an increase in the number of solar panels and batteries required for power. Once monitoring expands to both bridges, the authors recommend that an additional (permanent) power source be located or provided.

## References

- Gastineau, A., Johnson, T., and Schultz, A. *Bridge Health Monitoring and Inspection – A Survey of Methods*. Minnesota Department of Transportation, 2009, St. Paul, MN.
- Grosse, C., and Ohtsu, M. *Acoustic Emission Testing Basics for Research - Applications in Civil Engineering*. Springer EBooks. Berlin, Heidelberg: Springer-Verlag, 2008.  
<<https://www.lib.umn.edu/slog.phtml?url=http://dx.doi.org/10.1007/978-3-540-69972-9>>.  
Accessed December 2009.
- Hamstad, M.A. “Acoustic Emission Source Location in a Thick Steel Plate by Lamb Modes.” *Journal of Acoustic Emission*. 25 (2007): 194-214.
- Holford, K.M., Davies, A.W., Pullin, R. and Carter, D.C. "Damage Location in Steel Bridges by Acoustic Emission." *Journal of Intelligent Material Systems and Structures*. 12.8 (2001): 567-576.
- Huang, M., Jiang, L., Liaw, P., Brooks, C., Seeley, R., and Klarstrom, D. “Using Acoustic Emission in Fatigue and Fracture Materials Research.” *Journal of Minerals, Metals and Materials Society*. (1998). Web. Accessed February 2010.
- Miller, R.K., and Hill, E. *Acoustic Emission Testing*. American Society for Nondestructive Testing, 2005, Columbus, OH.
- Mistras Group, Inc. “Structural Health & Process Monitoring Outdoor AE & Sensor Fusion System.” (2009). Web. Accessed January 2010.
- Pullin, R., Baxter, M., Eaton, M., Holford, K., and Evans, S. “Novel Acoustic Emission Source Location.” *Journal of Acoustic Emission*. 25 (2007): 215-223.
- “Standard Guide for Mounting Piezoelectric Acoustic Emission Sensors.” *ASTM International*. Designation E 650 – 97 (Reapproved 2007): 1-3.
- “Standard Guide for Acoustic Emission System Performance Verification.” *ASTM International*. Designation E2374 – 10: 1-6.
- Williams, R.V. *Acoustic Emission*. Bristol: A. Hilger, 1980.

## **APPENDIX A: VENDOR SATISFACTION SURVEYS**

The appendix contains a blank vendor satisfaction survey and the three completed Mistras satisfaction surveys. The content of the Mistras satisfaction surveys have not been altered.

## Vendor Satisfaction Survey

- 1) What type of monitoring device was purchased from the vendor?
- 2) What is the application of the monitoring device?
- 3) How long has the monitoring device been in service?
- 4) Please rate your satisfaction with the vendor's assistance during the selection, installation, and set up of your monitoring device on a scale of 1 to 10, 10 being the best.
- 5) Please indicate the amount of maintenance done to the monitoring device since installation on a scale of 1 to 10, 1 being continuous maintenance and 10 being no maintenance.
- 6) Please rate your opinion of how well the vendor's monitoring device has been able to fulfill your monitoring needs on a scale of 1 to 10, 10 being the best.
- 7) Did your purchase from the vendor include monitoring software? If yes, please rate the software on a scale of 1 to 10, 10 being the best.
- 8) Please rate your overall satisfaction with the vendor's customer service on a scale of 1 to 10, 10 being the best.
- 9) Please rate your overall satisfaction with your monitoring device on a scale of 1 to 10, 10 being the best.
- 10) Additional Comments:



Mistras Satisfaction Survey

*Francesco Lanza di Scalea, Ph.D.  
University of California, San Diego*

- 1) What type of monitoring device was purchased from Mistras?  
Various Acoustic Emission systems
- 2) What is the application of the monitoring device?  
Damage detection in aerospace and civil structures
- 3) How long has the monitoring device been in service?  
8 years
- 4) Please rate your satisfaction with Mistras' assistance during the selection, installation, and set up of your monitoring device on a scale of 1 to 10, 10 being the best.  
10
- 5) Please indicate the amount of maintenance done to the monitoring device since installation on a scale of 1 to 10, 1 being continuous maintenance and 10 being no maintenance.  
8
- 6) Please rate your opinion of how well Mistras' monitoring device has been able to fulfill your monitoring needs on a scale of 1 to 10, 10 being the best.  
10
- 7) Did your purchase from Mistras include monitoring software? If yes, please rate the software on a scale of 1 to 10, 10 being the best.  
10
- 8) Please rate your overall satisfaction with Mistras's customer service on a scale of 1 to 10, 10 being the best.  
10
- 9) Please rate your overall satisfaction with your monitoring device on a scale of 1 to 10, 10 being the best.  
10
- 10) Additional Comments:  
Mistras is the best AE company in the world. Their systems provide superior capabilities both in terms of hardware and in terms of processing software.

Mistras Group Satisfaction Survey

*Pranaam Haldipur, Ph.D.  
Federal Highway Administration*

- 1) What type of monitoring device was purchased from Mistras?  
Sensor Highway Smart Monitor
- 2) What is the application of the monitoring device?  
Monitoring fatigue cracks in steel bridge components
- 3) How long has the monitoring device been in service?  
2 years
- 4) Please rate your satisfaction with Mistras' assistance during the selection, installation, and set up of your monitoring device on a scale of 1 to 10, 10 being the best.  
8
- 5) Please indicate the amount of maintenance done to the monitoring device since installation on a scale of 1 to 10, 1 being continuous maintenance and 10 being no maintenance.  
8
- 6) Please rate your opinion of how well Mistras' monitoring device has been able to fulfill your monitoring needs on a scale of 1 to 10, 10 being the best.  
7
- 7) Did your purchase from Mistras include monitoring software? If yes, please rate the software on a scale of 1 to 10, 10 being the best.  
7
- 8) Please rate your overall satisfaction with Mistras's customer service on a scale of 1 to 10, 10 being the best.  
8
- 9) Please rate your overall satisfaction with your monitoring device on a scale of 1 to 10, 10 being the best.  
7

## Mistras Satisfaction Survey

*Paul Ziehl, Ph.D.  
University of South Carolina*

- 1) What type of monitoring device was purchased from Mistras?  
DiSP 8-channel AE instrument and (later) Sensor Highway 16-channel AE instrument.
- 2) What is the application of the monitoring device?  
Laboratory and field monitoring of bridges and other test specimens.
- 3) How long has the monitoring device been in service?  
DiSP – since 2002; Sensor Highway – since 2009
- 4) Please rate your satisfaction with Mistras' assistance during the selection, installation, and set up of your monitoring device on a scale of 1 to 10, 10 being the best.  
10 for both systems.
- 5) Please indicate the amount of maintenance done to the monitoring device since installation on a scale of 1 to 10, 1 being continuous maintenance and 10 being no maintenance.  
10 – on one occasions the DAQ boards for the DiSP were sent back to Mistras for servicing. They were returned in a reasonable period of time and are now functioning very well. The Sensor Highway has required no maintenance.
- 6) Please rate your opinion of how well Mistras' monitoring device has been able to fulfill your monitoring needs on a scale of 1 to 10, 10 being the best.  
10
- 7) Did your purchase from Mistras include monitoring software? If yes, please rate the software on a scale of 1 to 10, 10 being the best.  
10 – we have found two very minor glitches with the software on the Sensor Highway System, both are being corrected.
- 8) Please rate your overall satisfaction with Mistras' customer service on a scale of 1 to 10, 10 being the best.  
10 – no problems whatsoever.
- 9) Please rate your overall satisfaction with your monitoring device on a scale of 1 to 10, 10 being the best.  
10
- 10) Additional Comments:  
Excellent company, strongly suggest using AE and getting it from Mistras. There are other companies but the software, support and etc. do not compare favorably with Mistras.

## **APPENDIX B: MONITORING SYSTEM IMPLEMENTATION PLAN**

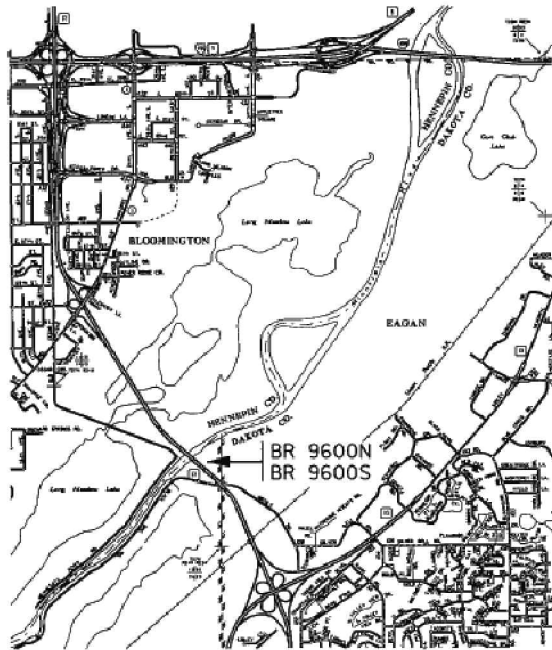
The appendix contains computer aided design drawings that detail the installation location, schedule, and procedure of the acoustic emission monitoring system. These drawings also contain specifications for initial testing of the system and a maintenance plan for the system.

PRODUCED BY AN AUTODESK EDUCATIONAL PRODUCT

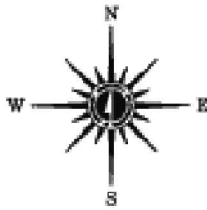
# MINNESOTA DEPARTMENT OF TRANSPORTATION

IMPLEMENTATION PLAN FOR BRIDGE 9600N & 9600S  
ACOUSTIC EMISSION SH-II SYSTEM INSTALLATION ALONG TIE GIRDER

LOCATED ON: T.H. 77 (CEDAR AVENUE) OVER MINNESOTA RIVER 1.0 MILES NORTH  
OF JUNCTION (IN EAGAN TOWNSHIP) OF T.H. 13 AND T.H. 77.



LIST OF SHEETS	
NO.	DESCRIPTION
1	TITLE SHEET
2-4	GENERAL PLAN AND ELEVATION OF SYSTEM INSTALLATION
5	SYSTEM PRICING
6	INSTALLATION SCHEDULE
7	INSTALLATION PROCEDURE
8	TESTING VERIFICATION AND MAINTENANCE PLAN



LEGEND



MN/DOT CONTRACT NO. 89261, WORK ORDER NO. 144, CFMS CONTRACT  
NO. B29437, UNIVERSITY OF MINNESOTA PROJECT 11104-00011560

SHEET 1 OF 8

PRODUCED BY AN AUTODESK EDUCATIONAL PRODUCT

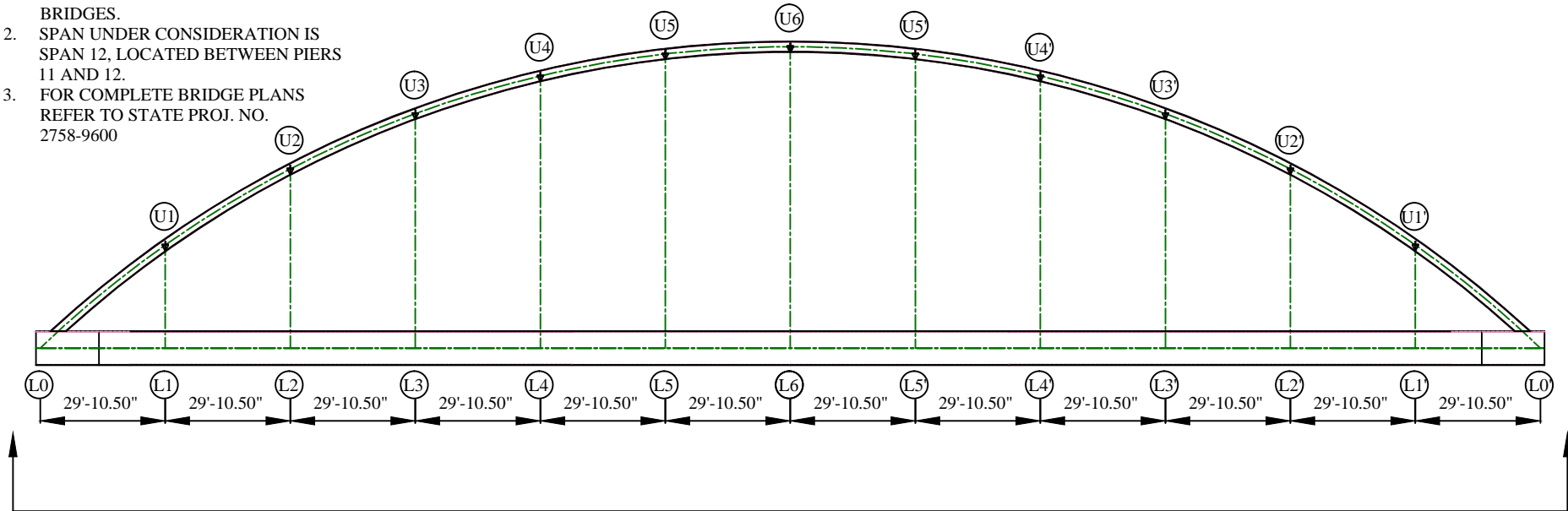
PRODUCED BY AN AUTODESK EDUCATIONAL PRODUCT

PRODUCED BY AN AUTODESK EDUCATIONAL PRODUCT

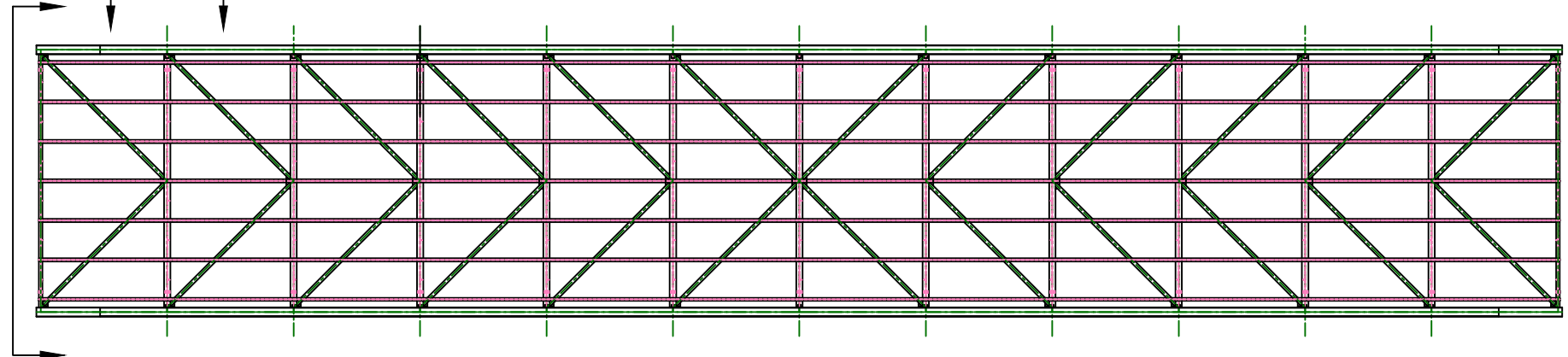
PRODUCED BY AN AUTODESK EDUCATIONAL PRODUCT

NOTE:

1. BOTH N.B. AND S.B. BRIDGES ARE TYPICAL. ONLY ONE BRIDGE WILL BE SHOWN IN IMPLEMENTATION PLAN FOR SIMPLICITY. USE SAME IMPLEMENTATION PLAN FOR BOTH BRIDGES.
2. SPAN UNDER CONSIDERATION IS SPAN 12, LOCATED BETWEEN PIERS 11 AND 12.
3. FOR COMPLETE BRIDGE PLANS REFER TO STATE PROJ. NO. 2758-9600



VIEW B  
4



VIEW A  
3

MN/DOT CONTRACT NO. 89261, WORK ORDER NO. 144, CFMS CONTRACT NO. B29437, UNIVERSITY OF MINNESOTA PROJECT 11104-00011560

SHEET 2 OF 8

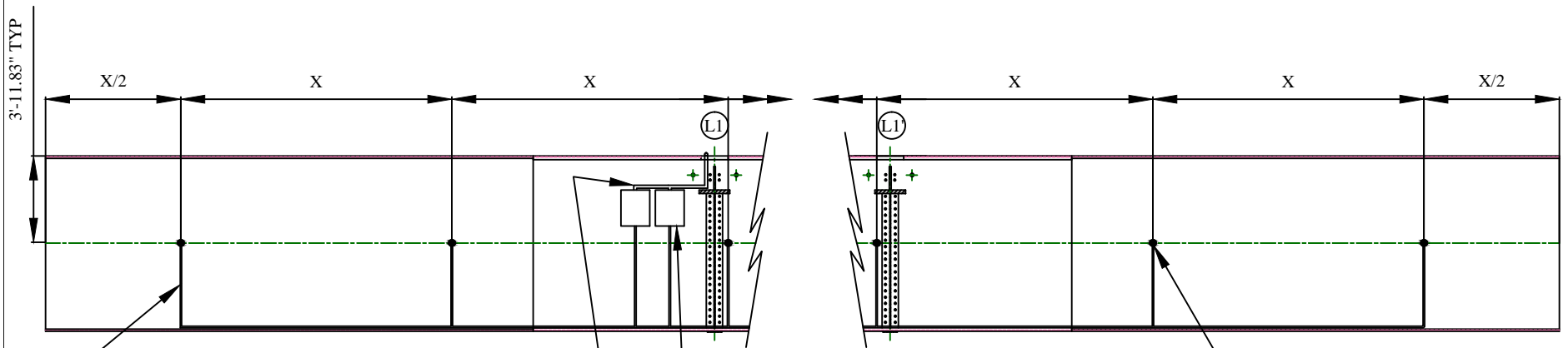
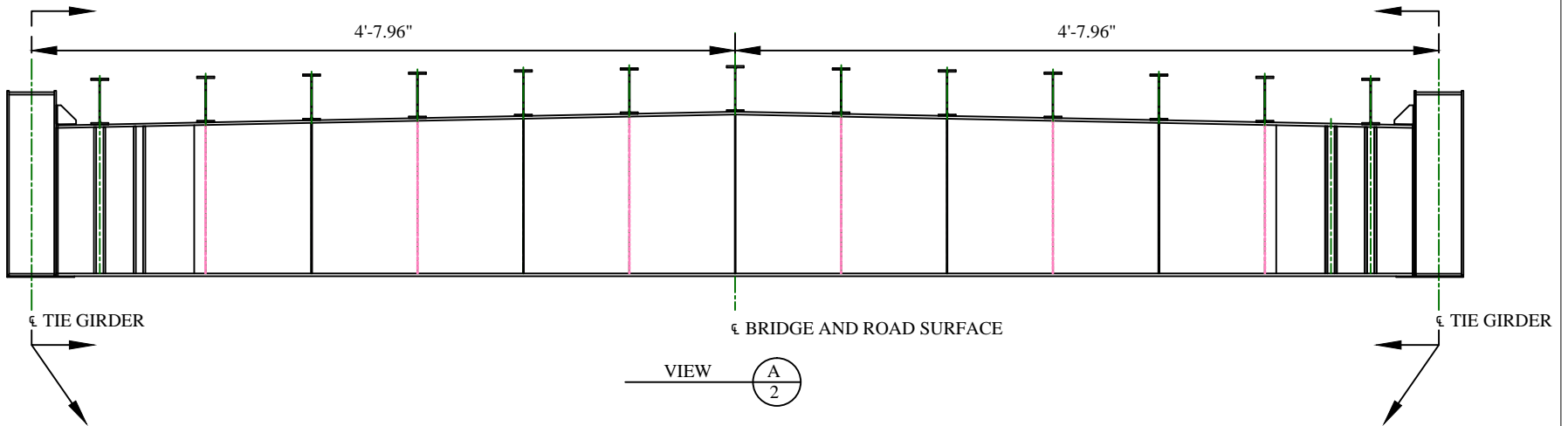
PRODUCED BY AN AUTODESK EDUCATIONAL PRODUCT

PRODUCED BY AN AUTODESK EDUCATIONAL PRODUCT

PRODUCED BY AN AUTODESK EDUCATIONAL PRODUCT

PRODUCED BY AN AUTODESK EDUCATIONAL PRODUCT

**NOTE:**  
ROAD SURFACE NOT SHOW FOR SIMPLICITY.



**ITEM 6:**  
SEE SHEET 6 FOR  
INSTALLATION  
SCHEDULE AND SHEET 7  
FOR INSTALLATION  
PROCEDURE OF SENSOR  
CABLE

**ITEM 8:**  
SEE SHEET 6 FOR  
INSTALLATION SCHEDULE AND  
SHEET 7 FOR INSTALLATION  
PROCEDURE OF POWER CABLE.

**ITEM 1:**  
SEE SHEET 6 FOR INSTALLATION  
SCHEDULE AND SHEET 7 FOR  
INSTALLATION PROCEDURE OF  
MODULE.

**ITEM 5:**  
SEE SHEET 6 FOR INSTALLATION  
SCHEDULE AND SHEET 7 FOR  
INSTALLATION PROCEDURE OF  
SENSOR.

**NOTE:**  
THE DIMENSION "X" IS THE SENSOR SPACING,  
WHICH IS YET TO BE DETERMINED. ONCE  
THE SENSOR SPACING IS DETERMINED, THIS  
SHEET IS TO BE UPDATED ACCORDINGLY.

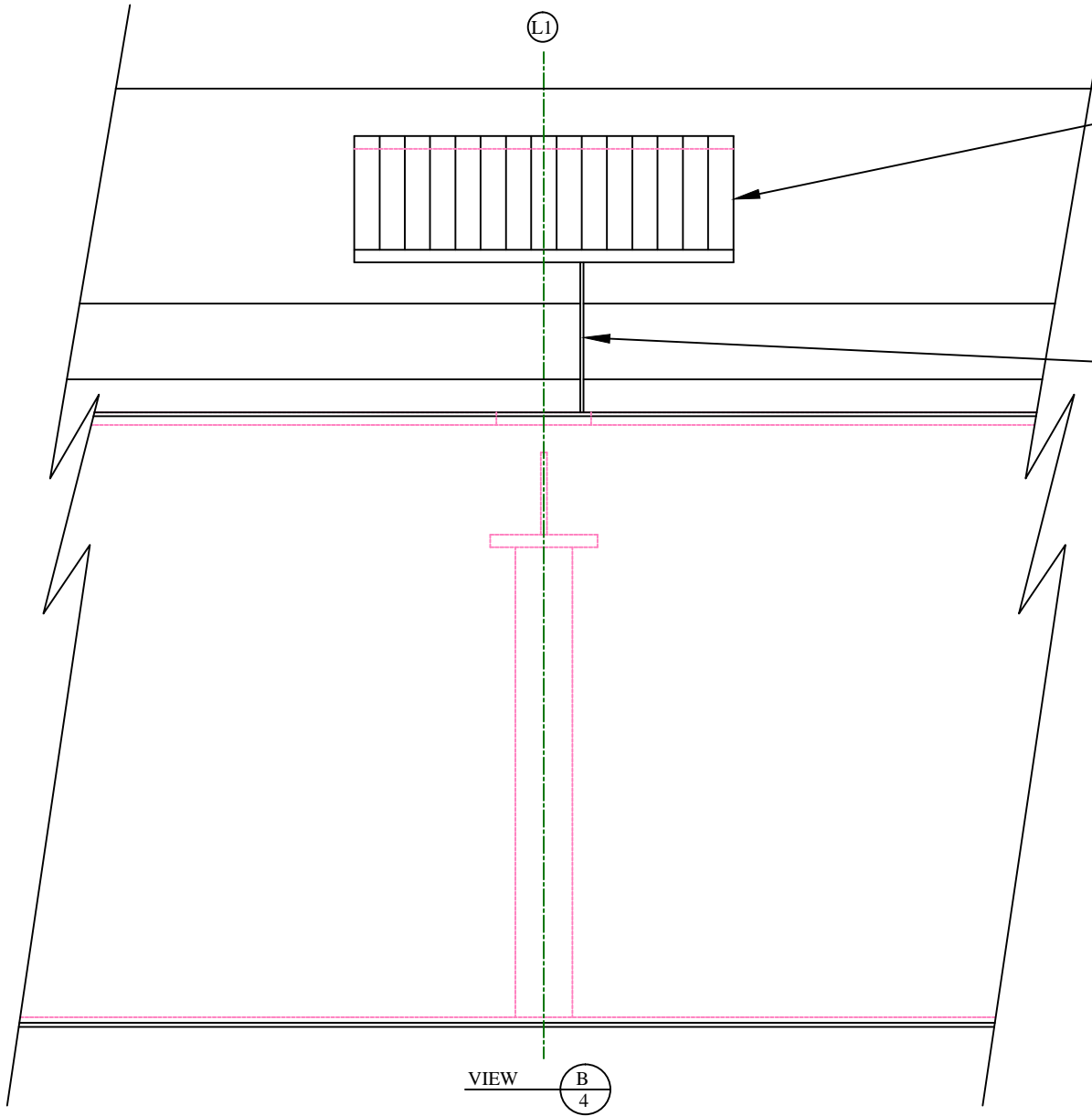
MN/DOT CONTRACT NO. 89261, WORK ORDER NO. 144, CFMS CONTRACT  
NO. B29437, UNIVERSITY OF MINNESOTA PROJECT 11104-00011560

SHEET 3 OF 8

PRODUCED BY AN AUTODESK EDUCATIONAL PRODUCT

PRODUCED BY AN AUTODESK EDUCATIONAL PRODUCT

PRODUCED BY AN AUTODESK EDUCATIONAL PRODUCT



**ITEM 9:**  
SEE SHEET 6 FOR INSTALLATION SCHEDULE AND SHEET 7 FOR INSTALLATION PROCEDURE OF SOLAR PANEL.

**ITEM 9:**  
SEE SHEET 6 FOR INSTALLATION SCHEDULE AND SHEET 7 FOR INSTALLATION PROCEDURE OF POWER CABLE.

**NOTE:**

1. APPARATUS TO ATTACH SOLAR PANEL TO CEDAR AVE. BRIDGE IS TO BE DESIGNED BY MN/DOT.
2. MINIMUM OF ONE SOLAR PANEL INSTALLED ON EACH BRIDGE. ADDITIONAL PANELS MAY BE REQUIRED.
3. EACH SOLAR PANEL PROVIDES 130 WATTS OF POWER.



**PRODUCED BY AN AUTODESK EDUCATIONAL PRODUCT**  
**BILL OF MATERIAL**

DESCRIPTION	PART NO.	ITEM NO.	QTY.	UNIT COST	TOTAL COST
SH-II-N MODULE	SH-II-N	1	1*	\$11,710.00	\$11,710.00
SH-II-SRM MODULE	9380-5025	1	1*	\$10,791.00	\$10,791.00
AE-WIN-SH-16 SOFTWARE	9380-7003	2	1	\$2,199.00	\$2,199.00
SH-BASESTATION OUTDOOR	SH-B.S.	3	1**	\$6,610.00	\$6,610.00
RMA SETUP CHARGES	9800-7110	4	1	\$2,625.00	\$2,625.00
SENSOR	R151-LP-AST	5	16*	\$552.00	\$8,832.00
COAXIAL CABLE	N/A	6	1**	\$1.00/FT	\$1.00/FT
RMA YEARLY FEE	9800-7110	7	1	\$1,050.00	\$1,050.00
WI-FI	9380-5065	8	1*	\$415.00	\$415.00
SOLAR PANEL KIT	9380-5165	9	1**	\$9,990.00	\$9,990.00

\*INDICATES A PER SYSTEM QTY.  
 \*\*INDICATES A QTY. THAT MAY INCREASE, DEPENDING ON SYSTEM SIZE

**EXAMPLE B.O.M. FOR X = 15 FT**

DESCRIPTION	PART NO.	QTY.	UNIT COST	TOTAL COST
SH-II-N MODULE	SH-II-N	8	\$11,710.00	\$93,680.00
SH-II-SRM MODULE	9380-5025	8	\$10,791.00	\$86,328.00
AE-WIN-SH-16 SOFTWARE	9380-7003	1	\$2,199.00	\$2,199.00
SH-BASESTATION OUTDOOR	SH-B.S.	1	\$6,610.00	\$6,610.00
RMA SETUP CHARGES	9800-7110	1	\$2,625.00	\$2,625.00
SENSOR	R151-LP-AST	96	\$552.00	\$52,992.00
COAXIAL CABLE	N/A	8,000	\$1.00	\$1,000.00
RMA YEARLY FEE	9800-7110	1	\$1,050.00	\$1,050.00
WI-FI	9380-5065	8	\$415.00	\$3320.00
SOLAR PANEL KIT	9380-5165	2	\$9,990.00	\$19,980.00

**EXAMPLE B.O.M. FOR X = 20 FT**

DESCRIPTION	PART NO.	QTY.	UNIT COST	TOTAL COST
SH-II-N MODULE	SH-II-N	8	\$11,710.00	\$93,680.00
SH-II-SRM MODULE	9380-5025	8	\$10,791.00	\$86,328.00
AE-WIN-SH-16 SOFTWARE	9380-7003	1	\$2,199.00	\$2,199.00
SH-BASESTATION OUTDOOR	SH-B.S.	1	\$6,610.00	\$6,610.00
RMA SETUP CHARGES	9800-7110	1	\$2,625.00	\$2,625.00
SENSOR	R151-LP-AST	72	\$552.00	\$39,744.00
COAXIAL CABLE	N/A	12,800	\$1.00	\$12,800.00
RMA YEARLY FEE	9800-7110	1	\$1,050.00	\$1,050.00
WI-FI	9380-5065	8	\$415.00	\$3320.00
SOLAR PANEL KIT	9380-5165	2	\$9,990.00	\$19,980.00

**EXAMPLE B.O.M. FOR X = 25 FT**

DESCRIPTION	PART NO.	QTY.	UNIT COST	TOTAL COST
SH-II-N MODULE	SH-II-N	4	\$11,710.00	\$46,840.00
SH-II-SRM MODULE	9380-5025	4	\$10,791.00	\$43,164.00
AE-WIN-SH-16 SOFTWARE	9380-7003	1	\$2,199.00	\$2,199.00
SH-BASESTATION OUTDOOR	SH-B.S.	1	\$6,610.00	\$6,610.00
RMA SETUP CHARGES	9800-7110	1	\$2,625.00	\$2,625.00
SENSOR	R151-LP-AST	60	\$552.00	\$33,120.00
COAXIAL CABLE	N/A	6,400	\$1.00	\$6,400.00
RMA YEARLY FEE	9800-7110	1	\$1,050.00	\$1,050.00
WI-FI	9380-5065	4	\$415.00	\$1660.00
SOLAR PANEL KIT	9380-5165	2	\$9,990.00	\$19,980.00

**NOTE:**

1. IN EXAMPLE BILL OF MATERIALS "X" IS THE SENSOR SPACING. QTY. IS FOR SENSOR INSTALLATION ON BOTH TIE GIRDERS ON BOTH N.B. AND S.B. BRIDGES.
2. ONLY EITHER THE SH-II-N OR SH-II-SRM MODULE NEED BE PURCHASED. ONCE A SH-II SYSTEM IS SELECTED THIS BILL OF MATERIAL IS TO BE UPDATED ACCORDINGLY.

# INSTALLATION SCHEDULE

## PRE-DELIVERY SCHEDULE

### PHASE 1: SYSTEM SELECTION AND ORDERING

1. SELECT THE SIZE OF THE INITIAL MONITORING SYSTEM.
2. SELECT SH-II-N OR SH-II-SRM MONITORING SYSTEM.
3. ORDER THE INITIAL MONITORING SYSTEM.

### PHASE 2: SOLAR PANEL KIT DESIGN

1. DESIGN THE MOUNTING APPARATUS FOR THE SOLAR PANEL KIT, WHILE AWAITING DELIVERY OF MONITORING SYSTEM.

### PHASE 3: LANE/SHOULDER CLOSURE PLAN

1. DEVELOP A LANE/SHOULDER CLOSURE PLAN ACCORDING TO MN/DOT AND OSHA SAFETY SPECIFICATIONS.

## POST-DELIVERY SCHEDULE

### PHASE 4: S.B. BRIDGE SOLAR PANEL INSTALLATION

1. IMPLEMENT LANE CLOSURE PLAN ON THE S.B. CEDAR AVE. BRIDGE AT 6:00 A.M.
2. INSTALL SOLAR PANEL KIT ON S.B. BRIDGE ACCORDING TO DESIGN SPECIFICATIONS AND SHEET 4 OF THIS PLAN.
3. INSTALLATION TO CONCLUDE NO LATER THAN 3:00 P.M. EACH DAY.
4. RETURN ALL LANES/SHOULDERS TO INITIAL CONFIGURATION.

### PHASE 5: N.B. BRIDGE SOLAR PANEL INSTALLATION

1. IMPLEMENT LANE CLOSURE PLAN ON THE N.B. CEDAR AVE. BRIDGE AT 1:00 P.M.
2. INSTALL SOLAR PANEL KIT ON N.B. BRIDGE ACCORDING TO DESIGN SPECIFICATIONS AND SHEET 4 OF THIS PLAN.
3. INSTALLATION TO CONCLUDE NO LATER THAN 10:00 P.M. EACH DAY.
4. RETURN ALL LANES/SHOULDERS TO INITIAL CONFIGURATION.

### PHASE 6: INSTALL SH-II CLIENT SOFTWARE

1. INSTALL SH-II CLIENT SOFTWARE ONTO THE USERS COMMUNICATION COMPUTER(S).

### PHASE 7: SENSOR CHECK

1. COMPLETE INITIAL TESTING OF EACH SENSOR (SEE SHEET 8) PRIOR TO INSTALLATION TO CHECK FOR DEFECTS.

### PHASE 8: S.B. BRIDGE SYSTEM INSTALLATION

1. IMPLEMENT ACCESS PROCEDURE ON THE S.B. CEDAR AVE. BRIDGE AT 6:00 A.M.
2. INSTALL SH-II MODULES AND SENSORS ACCORDING TO INSTALLATION PROCEDURE (SEE SHEET 7).
3. CONNECT POWER TO SH-II SYSTEM ACCORDING TO PROCEDURE (SEE SHEET 7).
4. COMPLETE VERIFICATION TESTING ON BOTH TIE GIRDERS (SEE SHEET 8).
5. COMPLETE INSTALLATION AND VERIFICATION TESTING BY 3:00 P.M. EACH DAY.
6. RETURN LANES/SHOULDERS TO INITIAL CONFIGURATION.

### PHASE 9: N.B. BRIDGE SYSTEM INSTALLATION

1. IMPLEMENT ACCESS PROCEDURE ON THE N.B. CEDAR AVE. BRIDGE AT 1:00 P.M.
2. INSTALL SH-II MODULES AND SENSORS ACCORDING TO INSTALLATION PROCEDURE (SEE SHEET 7).
3. CONNECT POWER TO SH-II SYSTEM ACCORDING TO PROCEDURE (SEE SHEET 7).
4. COMPLETE VERIFICATION TESTING ON BOTH TIE GIRDERS (SEE SHEET 8).
5. COMPLETE INSTALLATION AND VERIFICATION TESTING BY 10:00 P.M. EACH DAY.
6. RETURN LANE/SHOULDERS TO INITIAL CONFIGURATION.

### PHASE 10: INITIAL TESTING

1. DETERMINE SIZE OF FINAL MONITORING SYSTEM USING VERIFICATION TESTING PROCEDURE (SEE SHEET 8).
2. CONDUCT INITIAL TESTING TO CALIBRATE SYSTEM (i.e. SIGNAL CLUSTERING).
3. AUTOMATE MONITORING SYSTEM.

**PRODUCED BY AN AUTODESK EDUCATIONAL PRODUCT**  
**INSTALLATION PROCEDURE**

**SOLAR PANEL INSTALLATION PROCEDURE**

**PHASE 4-5:**

1. IMPLEMENT LANE CLOSURE PLAN.
2. INSTALL SOLAR PANEL ACCORDING TO DESIGN SPECIFICATIONS.
3. SOLAR PANEL TO BE INSTALLED LOCAL TO "L1" (SEE SHEET 4).

**ACCESS PROCEDURE**

**PHASE 8-10:**

1. LANES/SHOULDERS ARE TO BE CLOSED ACCORDING TO LANE/SHOULDER CLOSURE PLAN.
2. HANG LADDER OVER ACCESS DOOR FOR TIE GIRDER.
3. OPEN TIE GIRDER ACCESS DOOR.

**SYSTEM INSTALLATION: PHASE 8-9**

**STEP 1: SENSOR INSTALLATION**

1. MARK SENSOR INSTALLATION LOCATIONS ON CENTERLINE OF TIE GIRDER WEB (SEE SHEET 3).
2. MARKS TO BE AT EQUIDISTANCE "X" (SEE SHEET 3).
3. IF SENSOR SPACING "X" LEADS TO PLACING A SENSOR AT A "L#" CONNECTION OR TIE GIRDER STIFFENER, INSTALL SENSOR AT SHORTER SPACING DISTANCE AND UPDATE SHEET 3 ACCORDINGLY.
4. DO NOT INSTALL SENSORS ON CURVED SURFACE, WELD, OR PAINTED SURFACE.
5. NAME SENSORS ACCORDING TO LOCATION, COUNTING UP FROM L1 (i.e. N.B. EAST GIRDER SENSOR 8).
6. CLEAN SURFACE OF SENSOR INSTALLATION LOCATIONS PRIOR TO INSTALLATION.
7. APPLY SMALL AMOUNT OF COUPLANT (PROVIDED BY MISTRAS) TO SENSOR FACE.
8. CAREFULLY PRESS SENSOR ON TO THE TIE GIRDER WEB.
9. ENSURE THAT COUPLANT SPREAD EVENLY WITH NO GAPS ON SENSOR SURFACE.
10. ATTACH SENSOR TO STRUCTURE SURFACE USING MAGNETIZED MOUNTING FIXTURE.

**STEP 2: MODULE INSTALLATION**

1. MARK MODULE INSTALLATION LOCATIONS ON CENTERLINE OF TIE GIRDER LOCAL TO L1 (SEE SHEET 3).
2. NAME MODULES ACCORDING TO LOCATION (i.e. S.B. EAST GIRDER MODULE 1).
3. CLEAN SURFACE OF MODULE AND INSTALLATION LOCATION ON STRUCTURE.
4. ATTACH MODULE TO STRUCTURE SURFACE USING MAGNETIZED MOUNTING FIXTURE.

**SYSTEM INSTALLATION CONTINUED: PHASE 8-9**

**STEP 3: POWER CABLE INSTALLATION**

1. REMOVE HANGER CONNECTION SEALANT AND COVER PLATE.
2. DRILL HANGER CONNECTION COVER PLATE TO ACCOMMODATE FOR POWER CABLE.
3. RUN POWER CABLE THRU HANGER CONNECTION COVER PLATE.
4. CLEAN STRUCTURE ALONG PATH OF POWER CABLE.
5. ENSURE SUFFICIENT POWER CABLE LEAD FOR CONNECTION TO SOLAR PANEL AND SH-II MODULE.
6. ATTACH POWER CABLE TO STRUCTURE SURFACING USING AN EPOXY.
7. ENSURE POWER CABLE CANNOT VIBRATE OR MOVE.
8. REATTACH HANGER CONNECTION COVER PLATE.
9. RESEAL HANGER CONNECTION.
10. DO NOT CONNECT POWER CABLE TO SH-II MODULE OR SOLAR PANEL.

**STEP 4: SENSOR CABLE INSTALLATION**

1. THREAD COAXIAL CABLE TO SENSOR.
2. CLEAN STRUCTURE SURFACE ALONG PATH OF COAXIAL CABLE FROM SENSOR TO MODULE.
3. ATTACH CABLE TO STRUCTURE USING AN EPOXY.
4. ENSURE CABLE CANNOT VIBRATE.

**STEP 5: CONNECT SH-II SYSTEM**

1. OPEN THE COVER OF THE SH-II MODULE AND MAKE SURE THE POWER SWITCH IS IN THE OFF POSITION.
2. CONNECT POWER CABLE TO SURGE PROTECT BY THREADING THE CABLE THROUGH THE GLAND CONNECTOR. BE SURE TO CONNECT ALL WIRES.
3. CONNECT SENSORS TO THE INPUTS ON THE MODULE BY THREADING THE WIRE THROUGH THE GLAND CONNECTOR. START BY CONNECTING THE NEAREST SENSOR IN CHANNEL #1.
4. CONNECT AN ACTIVE ETHERNET LINE TO THE RJ45 ETHERNET CONNECTOR ON THE BOTTOM PANEL OF THE SH-II MODULE.
5. CONNECT THE POWER CABLE TO THE SOLAR PANEL AND TURN THE SH-II MODULE POWER SWITCH ON. LOOK FOR GREEN AND RED BLINKING LED'S TO ENSURE SH-II IS ON.
6. ALLOW ABOUT 3 MINUTES FOR SH-II SYSTEM TO COMPLETE SELF-CALIBRATION.
7. TIGHTEN ALL GLAND CONNECTORS.
8. SET UP SH-II CLIENT SOFTWARE ACCORDING TO SH-II USER'S MANUAL.

**STEP 6: VERIFICATION TESTING**

1. SEE SHEET 8 (INITIAL TESTING).

**PRODUCED BY AN AUTODESK EDUCATIONAL PRODUCT**  
**INITIAL TESTING AND MAINTENANCE PLAN**

**INITIAL TESTING**

**SYSTEM VERIFICATION TESTING :**

1. ACQUIRE A MECHANICAL PENCIL WITH A 2.5mm LEAD EXTENTION, 2H HARDNESS AND 0.3mm DIAMETER.
2. SELECT A DISTANCE FROM PENCIL LEAD BREAK (PLB) TO SENSOR, AND KEEP THIS DISTANCE CONSTANT FOR ALL TESTS.
3. HOLD THE PENCIL AT 30 DEGREES TO THE STRUCTURE SURFACE.
4. BREAK THE PENCIL THREE TO FIVE TIMES.
5. CONSULT ASTM E1419 TO ENSURE MEETING THE MINIMUM SIGNAL AMPLITUDE REQUIREMENTS FOR AN A.E. SENSOR.
6. IF A SENSOR HAS AN UNACCEPTABLY LOW SIGNAL AMPLITUDE, REMOVE THE SENSOR, REMOVE THE COUPLANT, RE-APPLY THE COUPLANT AND RE-INSTALL THE SENSOR, AND TEST THE SENSOR AGAIN.
7. IF THE PROBLEM PERSISTS, REPLACE THE CABLE AND TEST THE SENSOR AGAIN.
8. IF THE PROBLEM PERSISTS, REPLACE THE SENSOR.
9. COMPLETE THIS PROCEDURE FOR ALL SENSORS IN ALL GIRDERS AT THE COMPLETION OF SYSTEM INSTALLATION.
10. COMPLETE A REPORT DETAILING: THE TEST METHOD, RESULTS, AND RESPONSE.

**MAINTENANCE PLAN**

**MAINTENANCE PLAN (GENERAL NOTES):**

1. ONLY IMPLEMENT MAINTENANCE PLAN IF SENSORS ARE NOT RECEIVING SIGNALS OR RECEIVING FALSE SIGNALS.
2. FIRST YEAR OF SYSTEM PURCHASE, SYSTEM IS UNDER MANUFACTURER'S WARRANTY PROVIDED BY MISTRAS GROUP. IF ANY OF THE PRODUCTS PURCHASED BY MN/DOT FROM MISTRAS CONTAIN DEFECTS IN DESIGN, AND DO NOT OPERATE UNDER NORMAL USE AND SERVICE FOR ONE YEAR AFTER SHIPMENT: MISTRAS WILL REPAIR OR REPLACE ALL DEFECTIVE PARTS FREE OF CHARGE.

**MAINTENANCE PLAN:**

1. IF SENSOR IS RECEIVING FALSE SIGNALS CHECK AREA LOCAL TO SENSOR FOR VIBRATING CABLES AND RUBBING SURFACES.
2. IF CABLES ARE VIBRATING, REAPPLY EPOXY TO CABLES TO ENSURE VIBRATION DESISTS.
3. IF PROBLEM PRESISTS, FOLLOW THE STEPS BELOW.
4. REMOVE FAULTY SENSOR AND COUPLANT.
5. REAPPLY COUPLANT, AND REATTACH SENSOR ACCORDING TO INSTALLATION PROCEDURE.
6. COMPLETE SYSTEM VERIFICATION TESTING LOCAL TO SENSOR.
7. IF PROBLEM PERSISTS, REPLACE CABLE CONNECTING SENSOR TO MODULE, FOLLOWING CABLE INSTALLATION PROCEDURE.
8. COMPLETE SYSTEM VERIFICATION TESTING LOCAL TO SENSOR.
9. IF PROBLEM PERSISTS, REPLACE SENSOR, FOLLOWING SENSOR INSTALLATION PROCEDURE.
10. COMPLETE SYSTEM VERIFICATION TESTING LOCAL TO SENSOR.
11. IF PROBLEM PERSISTS, CONTACT MISTRAS GROUP FOR MODULE TROUBLESHOOTING PROCEDURE.

PRODUCED BY AN AUTODESK EDUCATIONAL PRODUCT

PRODUCED BY AN AUTODESK EDUCATIONAL PRODUCT

## **APPENDIX C: MISTRAS GROUP SYSTEM QUOTES**

The appendix contains unsigned quotes from Mistras for the Sensor Highway – II Networked and Sensor Highway – II Smart Remote Monitoring systems.

March 24, 2010

Arturo E Schultz, PhD.  
**University of Minnesota**  
Civil Engineering Dept.  
500 Pillsbury Drive  
Minneapolis, MN 55455-0116  
E: [schul088@umn.edu](mailto:schul088@umn.edu)

**Re: Sensor Highway II SRM Quotation**  
**Quote # SH- 8227 Rev B**

Dear Dr. Schultz:

The following is our quotation for our Sensor Highway II System, including sensors and software. Optional items that can be added to this quote are quoted separately and can be added in part or in whole to the cost of the base system.

The Sensor Highway II has several communication interfaces available for data communication and remote control. The principal interface is its built-in Ethernet 10/100 (and optionally, wireless Ethernet). Other available interfaces include: Telephone modem, RS-232/485, USB host and device, 4 – 20ma and digital I/O, and relay outputs for alarm and control purposes.

The Sensor Highway case size is approximately 20" x 16" x 6" deep. The AE Sensor Highway is scalable for large factory use, allowing for multiple units to be placed near the machinery or structures that are being monitored. There is no theoretical limit to the number of overall channels (based on 16 channel separate units) that can be connected in one location (plant).

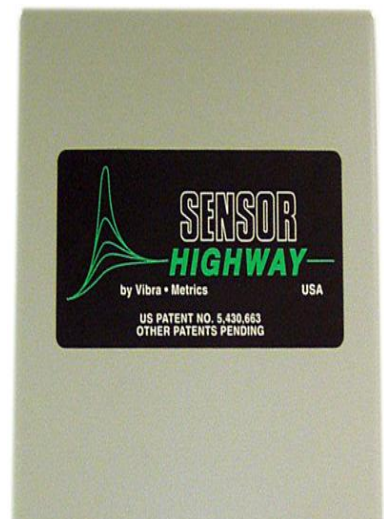


Figure 1. **Sensor Highway in NEMA case**



Figure 2. **Inside the Sensor Highway Cabinet**

The system is designed for outdoor environments, with a minimum power dissipation and a temperature range of (-35° - 70° C) without the need for heaters or air conditioners.

For more information please contact me at your convenience.

### **Cost Breakdown for Base System**

Item	Model & Description	QTY	Unit Price	Total Price
	<b>8 CHANNELS</b>			
001	PN# SH-II-N, <b>SH-II-N</b> , Networked, Smart Remote, Sensor Highway system. Use with systems requiring more than 16 channels and time-of-test synchronization (operating as one AE system). Includes; Outdoor case, Sensor Highway 16 channel motherboard (0 channels), Atom N270, wide temperature range CPU, 2GB Internal SSD, 64GB SATA SSD, Windows XP Operating System, AEwin ready, and Ethernet connectivity to a factory network or Internet. Time synchronization capability between units up to 12 feet. 110/220VAC or 9 - 28 VDC power at 30 watts (not including sensor/preamp requirements). Requires AEwin software on each node. (Basestation required).	1	\$11,170.00	\$11,170.00
002	PN#9380-2054, <b>SH-4 AE</b> , 4 channel AE plug-in module for Sensor Highway with 1 MHz AE bandwidth. 4 modules maximum in one Sensor Highway chassis.	2	\$1,574.00	\$3,148.00
003	PN# 9380-7003, <b>AEwin-SH-16</b> , "AE win for Sensor Highway Smart Monitor" to 16 channel, full and automated AE data collection, file link, signal and alarm processing and remote communication software.	1	\$2,199.00	\$2,199.00
004	PN# SH-BaseStation Outdoor, <b>SH-BaseStation Outdoor</b> , BaseStation for use outdoors (NEMA-4, IP 66). Connects up to 16 Sensor Highway units, with low power disappation, wide temperature range (-20 to 65°C) CPU, embedded XP Operating system, Memory, with 4 GByte Compact Flash card, and Ethernet Multi-Port Switch for direct connection to Sensor Highway units and Internet.	1	\$6,610.00	\$6,610.00
005	PN# 9800-7110-setup, <b>RMA Setup Charges</b> , PAC Internet monitoring, "Remote Monitoring Application", (RMA) includes any AE system preparations for Remote access here in Princeton, phone/email support once system is delivered, as well as "standard", web hosting account setup charges for opening customer unique, personalized, secure, website. (Other special requests are extra. Consult factory)	1	\$2,625.00	\$2,625.00
006	PN# R15I-LP-AST, <b>R15I-LP-AST</b> , Low Power, Preamplified Sensor, 150kHz, with 26 dB gain, AST, coated for outdoor use, 5 meter coaxial RG-58A/U cable, BNC connector.	8	\$552.00	\$4,416.00
	<b>Subtotal:</b>			<b>\$30,168.00</b>

Item	Model & Description	QTY	Unit Price	Total Price
	<b>16 CHANNELS</b>			
001	PN# SH-II-N, <b>SH-II-N</b> , Networked, Smart Remote, Sensor Highway system. Use with systems requiring more than 16 channels and time-of-test synchronization (operating as one AE system). Includes; Outdoor case, Sensor Highway 16 channel motherboard (0 channels), Atom N270, wide temperature range CPU, 2GB Internal SSD, 64GB SATA SSD, Windows XP Operating System, AEwin ready, and Ethernet connectivity to a factory network or Internet. Time synchronization capability between units up to 12 feet. 110/220VAC or 9 - 28 VDC power at 30 watts (not including sensor/preamp requirements). Requires AEwin software on each node. (Basestation required).	1	\$11,170.00	\$11,170.00
002	PN#9380-2054, <b>SH-4 AE</b> , 4 channel AE plug-in module for Sensor Highway with 1 MHz AE bandwidth. 4 modules maximum in one Sensor Highway chassis.	4	\$1,574.00	\$6,296.00
003	PN# 9380-7003, <b>AEwin-SH-16</b> , "AE win for Sensor Highway Smart Monitor" to 16 channel, full and automated AE data collection, file link, signal and alarm processing and remote communication software.	1	\$2,199.00	\$2,199.00
004	PN# SH-BaseStation Outdoor, <b>SH-BaseStation Outdoor</b> , BaseStation for use outdoors (NEMA-4, IP 66). Connects up to 16 Sensor Highway units, with low power disappation, wide temperature range (-20 to 65°C) CPU, embedded XP Operating system, Memory, with 4 GByte Compact Flash card, and Ethernet Multi-Port Switch for direct connection to Sensor Highway units and Internet.	1	\$6,610.00	\$6,610.00
005	PN# 9800-7110-setup, <b>RMA Setup Charges</b> , PAC Internet monitoring, "Remote Monitoring Application", (RMA) includes any AE system preparations for Remote access here in Princeton, phone/email support once system is delivered, as well as "standard", web hosting account setup charges for opening customer unique, personalized, secure, website. (Other special requests are extra. Consult factory)	1	\$2,625.00	\$2,625.00
006	PN# R15I-LP-AST, <b>R15I-LP-AST</b> , Low Power, Preamplified Sensor, 150kHz, with 26 dB gain, AST, coated for outdoor use, 5 meter coaxial RG-58A/U cable, BNC connector.	16	\$552.00	\$8,832.00
	<b>Subtotal:</b>			<b>\$37,732.00</b>

**See Cost Breakdown for Optional Equipment on Following Page**



Item	Model & Description	QTY	Unit Price	Total Price
001	<b>PN# 9800-7110-Maint , RMA Yearly Maintance fee</b> , Yearly Remote Monitoring Usage and Maintenance fee. Starts after 1st year.	1	\$1,050.00	\$1,050.00
002	<b>PN# 9380-5065 , Wi-Fi</b> , WiFi wireless Ethernet connectivity from Sensor Highway to BaseStation or BaseStation to Internet. Price is each.	1	\$415.00	\$415.00
003	<b>PN# 9380-5165 , Solar Panel Kit, Stand Alone 520 Watt Solar Power Kit</b> with 4 days of Battery Backup. Includes (4) 130 Watt Solar Panels, (4) 110Ah batteries with enclosure, 45A Charge controller and 400 Watt AC Inverter with enclosure, Pole or Structure monuting hardware. Site Installation Not Included	1	\$9,990.00	\$9,990.00
004	<b>pn# 9380-5035, Cellular Wireless Modem</b> , Wirless 3G modem with remote CPU reset capability. Hardware only. Needs a separate cellular contract provided by customer (For U.S. and Verizon service only).	1	\$1,675.00	\$1,675.00
005	<b>PN# 9380-5045 , SH Battery Backup</b> , Battery Backup option installed into system offers up to 20 minutes operation. (Not needed if you buy Solar Panel Option)	1	\$415.00	\$415.00
009	<b>PN# 9381-5015 , Signal Conditioner</b> , DIN rail accelerometer and thermacouple conditioner for SHII. It allows ICP accelerometer and thermagage to be connected to the parametric input of SHII directly.	1	\$624.00	\$624.00

Validity: 90 Days  
 Payment Terms: Net 30 days upon approval by Accounting. We also accept credit cards, (VISA, MasterCard Discover & American Express)  
**NOTE: there will be a 3.5% processing fee levied on total of order when using a credit card for orders of \$5000.00 or over.**  
 Delivery: 45-60 Days ARO  
**FOB: Princeton Junction, NJ , Buyer understands that he/she is responsible for shipment, insurance and any damages caused by shipping, from the FOB Shipping Point.**  
 Ship Via: UPS Ground **PP & Add to invoice** or collect with customers account number  
 Origin: Made in USA  
 Minimum Order: \$100

Place an Order: Please submit documents to [sales@pacndt.com](mailto:sales@pacndt.com) or by fax to 609-716-0706

I trust that the specifications and options are clear, but if you have any questions or comments, please do not hesitate to call. We appreciate your inquiry and look forward to doing business with you in the near future. If you visit our website at [www.mistrasgroup.com](http://www.mistrasgroup.com), there is some helpful information on our products.

Best regards,

*Terry Tamutus*

Terry Tamutus  
Regional Sales Manager – NorthEast  
Products & Systems Division  
**Mistras Group, Inc.**  
P: 609-468-5737  
E: [terry.tamutus@mistrasgroup.com](mailto:terry.tamutus@mistrasgroup.com)

<TAT/eg>

**MISTRAS GROUP INC.**  
**GENERAL TERMS AND CONDITIONS of SALE**

- 1) Acceptance of customer's order is expressly made conditional on assent to the terms and conditions set forth herein and on attachment(s) hereto and they shall constitute the complete agreement between the parties. These terms and conditions may not be varied, or Customer's order terminated in any manner unless by written agreement, with legal consideration, signed by an office of MISTRAS GROUP INC. (also referred to herein as "MISTRAS" or "The Company"). Other representatives of the company are not authorized to vary the conditions herein set forth. Failure to specifically dissent to these terms and conditions or customer's acceptance of any goods covered by this acknowledgment shall constitute acceptance of said terms and conditions and they shall be controlling in every case.

- 2) Unless otherwise specified in writing, all proposals expire ninety (90) days from the date of proposal.
- 3) Unless stated to the contrary on the face hereof, all goods furnished hereunder will be shipped F.O.B. point of shipment, and title in and the right of possession to such goods pass to the customer upon the company's delivery to carrier at point of shipment. Any loss in transit after FOB shipment is the sole responsibility of the customer.
- 4) Unless specified otherwise in writing by MISTRAS, payment terms are net cash, payable without offset, in US dollars, with approved credit, paid 30 days from the date of invoice.
- 5) Purchaser shall pay, in addition to any overdue payment, a late charge of 1.5% per month, on all overdue amounts plus any collection fees, MISTRAS attorney fees and, court costs in connection to collection.
- 6) Tooling, set-up, fitting-up, drawings, design information and partial preparation charges when invoiced cover only part of the cost thereof to the company. The customer does not acquire any right, title or interest in any tooling, set-up, fitting-up, drawings, design information, or invention resulting therefrom.
- 7) Any inspection by the Purchaser of Equipment on MISTRAS premises shall be scheduled in advance and performed during normal working hours.
- 8) On orders where there are partial payments due to MISTRAS based on meeting specific measurable milestones, these invoices/payments represent work completed by MISTRAS and rightfully earned and owned by MISTRAS, without any recourse.
- 9) If the order provides for site acceptance testing to verify that the equipment has arrived at the site complete, without physical damage, and in good operating condition, completion of site acceptance test constitutes full and final acceptance of the equipment. If, through no fault of MISTRAS, acceptance testing is not completed within thirty (30) days after arrival of the equipment at the site, the site acceptance test shall be deemed completed and the equipment shall be deemed accepted and any remaining payments due MISTRAS will be paid by the buyer.
- 10) All shipping dates are tentative. The company will not be responsible for delays of non-performance directly or indirectly caused by governmental regulations or requirements, act of God, unavailability of materials, work stoppages, slow downs, boycotts, and other causes (whether or not similar in nature to any of these hereinbefore specified) beyond the company's reasonable control.
- 11) This company's line of products requires close coordination of the customer's requirements with the company's production schedules to avoid possible delays in shipment. Accordingly, the company reserves the right to ship approximately thirty days in advance of shipping date.
- 12) THERE IS NO WARRANTY BY THE COMPANY THAT THE GOODS SHALL BE DELIVERED free from any claim of any third person by way of infringement of Trademarks, Patents or Copyrights.
- 13) Seller warrants that the articles delivered or used hereunder shall be free from defects in material, workmanship and fabrication. This WARRANTY shall extend for a period of one (1) year after date of delivery of such articles to Buyer. SELLER MAKES NO WARRANTY, EXPRESS, IMPLIED (INCLUDING BUT NOT LIMITED TO WARRANTIES OF MERCHANTABILITY AND FITNESS FOR INTENDED PURPOSE), OR STATUTORY, OTHER THAN THE FOREGOING EXPRESS WARRANTY. Failure of Buyer to submit any claim hereunder within ninety (90) days after receipt of such articles shall be an admission by buyer and conclusive proof that such articles are in every respect as warranted and shall release Seller from any and all claims for damage or loss sustained by Buyer, in the event Buyer timely submits a claim for breach of WARRANTY, the parties agree that Buyer's role and exclusive remedy shall be the repair or replacement of such defective article. IN NO EVENT SHALL SELLER BE LIABLE FOR INCIDENTAL OR CONSEQUENTIAL DAMAGE OF THE PURCHASER, USER OR THIRD PARTIES. Seller's warranties shall inure to the benefit of the original user only.
- 14) Factory service by personnel from the United States for loaned or purchased items, if required, is available at a charge of prevailing labor rate per man-day, plus expenses and parts. Spare and replacement parts for the tool(s), and/or machine(s), and/or applicator(s), can be purchased from the company.
- 15) The company shall have the right to suspend or cancel this agreement at any time upon customer making an assignment for the benefit of creditors or becoming bankrupt or insolvent, or upon a petition being filed in a court of competent jurisdiction proposing the appointment of a receiver or that the customer be adjudicated bankrupt or insolvent or reorganized under the provisions of any applicable bankruptcy or insolvency act.
- 16) The company represents that with respect to the production of the articles and/or the performance of the services stated herein, it has fully complied with all the applicable provisions of the Fair Labor Standards Act of 1938, as amended, including section 6, 7 and 12, regulations under section 14, and all other applicable Administrative Regulations.
- 17) Any order may be cancelled before shipment by Purchaser only upon written notice and payment of termination charges, including but not limited to, all costs identified to the order incurred prior to the effective date of notice of termination and all expenses incurred by MISTRAS attributable, plus a fixed sum of fifteen (15) percent of the final total price to compensate for disruption in scheduling, planned production and other indirect costs.
- 18) MISTRAS warrants that, except as specified below, the software will, when properly installed, execute in accordance with MISTRAS's specification. If a nonconformity to the foregoing warranty is discovered during the period ending one (1) year after date of

shipment and written notice of such nonconformity is provided to MISTRAS promptly after such discovery and within that period, including a description of the nonconformity and complete information about the manner of the discovery, MISTRAS shall correct the nonconformity by, at its option, either (i) modifying or making available to the Purchaser instructions for modifying the Software, or (ii) making available at MISTRAS's facility necessary corrected or replacement programs. MISTRAS shall have no obligation with respect to nonconformities resulting from (i) unauthorized modification of the Software or (ii) Purchaser-supplied software or interfacing. MISTRAS does not warrant that the functions contained in the software will operate in combinations which may be selected for use by the Purchaser, or that the software products are free from errors in the nature of what is commonly categorized as "bugs". MISTRAS owns all rights in or has right to sublicense all of the software, if any, to be delivered to Purchaser under this Agreement. As part of this sale made hereunder Purchaser hereby obtains a limited license to use Software, subject to the following: (i) The software may be used only in conjunction with Equipment specified or approved by MISTRAS, (ii) The software shall be kept strictly confidential, (iii) The software shall not be copied, reverse engineered, or modified, (iv) the Purchaser's right to use the software shall terminate immediately when specified equipment is no longer used by the Purchaser or when otherwise terminated and (v) the rights to use the software are non-exclusive and non-transferrable, except with MISTRAS prior written consent.

- 19) In addition to the rights and remedies reserved herein, the company shall have all rights and remedies conferred by law and shall not be required to proceed with performance for the contract arising herefrom if customer is in default to the company under this or any other contract. This agreement shall be construed in accordance with the laws of the State of New Jersey, U.S.A.
- 20) The prices stated in this acknowledgment do not include, unless specifically stated, any special processing charges (e.g. Letters of Credit, wire transfer fee's, bank fee's, etc.), credit card charges, sales, use or other taxes and if such are payable in connection with this order they shall become an additional charge to the Purchaser.
- 21) In no event shall MISTRAS, its suppliers or subcontractors be liable for special, indirect, incidental, or consequential damages, whether in contract, warranty, tort, negligence, strict liability or otherwise, including, but not limited to, loss of profits or revenue, loss of use of the equipment or any associated equipment, cost of capital, cost of substitute equipment, facilities or services, downtime costs, delays, and claims of customers of the Purchaser or other third parties for any damages. MISTRAS liability for any claim whether in contract, warranty, tort, negligence, strict liability, or otherwise for any loss or damage arising out of, connected with, or resulting from this agreement or the performance or breach thereof, or from the design, manufacture, sale, delivery, resale, repair, replacement, installation, technical direction of installation, inspection, operation or use of any equipment covered by or furnished under this agreement, or from any services rendered in connection therewith, shall in no case exceed on-half (1/2) of the purchase price allocable to the equipment or part thereof or services which gave rise to this claim.
- 22) This sales order acknowledgment constitutes SELLER'S offer to BUYER upon the terms and conditions stated herein and shall become a binding contract on the terms set forth herein when it is accepted by BUYER either by acknowledgement or by acceptance of the goods sold hereunder. By acceptance of the goods referred to herein BUYER thereby understands and agrees that SELLER will not and need not analyze any of the terms, conditions and other provisions contained in BUYER'S purchase order other than to determine the product or service ordered, quantities and shipping data. BUYER also agrees that SELLER may disregard all terms, conditions and provisions of any such purchase order that do not comply herewith and may fulfill such part of the terms, conditions, and provisions thereof as shall comply herewith. Any variation of the terms and conditions herein must be specifically accepted in writing by SELLER.

March 24, 2010

Arturo E Schultz, PhD.  
**University of Minnesota**  
Civil Engineering Dept.  
500 Pillsbury Drive  
Minneapolis, MN 55455-0116  
E: [schul088@umn.edu](mailto:schul088@umn.edu)

Re: Sensor Highway II Quotation  
Quote # SH- 8227

Dear Dr. Schultz:

The following is our quotation for our Sensor Highway II System, including sensors and software. Optional items that can be added to this quote are quoted separately and can be added in part or in whole to the cost of the base system.

The Sensor Highway II has several communication interfaces available for data communication and remote control. The principal interface is its built-in Ethernet 10/100 (and optionally, wireless Ethernet). Other available interfaces include: Telephone modem, RS-232/485, USB host and device, 4 – 20ma and digital I/O, and relay outputs for alarm and control purposes.

The Sensor Highway case size is approximately 20" x 16" x 6" deep. The AE Sensor Highway is scalable for large factory use, allowing for multiple units to be placed near the machinery or structures that are being monitored. There is no theoretical limit to the number of overall channels (based on 16 channel separate units) that can be connected in one location (plant).



The system is designed for outdoor environments, with a minimum power dissipation and a temperature range of (-35° - 70° C) without the need for heaters or air conditioners. For more information please contact me at your convenience.

Figure 2. Inside the Sensor Highway Cabinet

**Cost Breakdown for Base System**

Item	Model & Description	QTY	Unit Price	Total Price
	<b>8 CHANNELS</b>			
001	<i>PN#9380-5025 , SH-II-SRM , Smart Remote Monitoring, Sensor Highway system is a full, stand-Alone AE system for unattended monitoring in outdoor environments. System Includes; Outdoor case, Sensor Highway 16 channel motherboard (0 channels installed), Atom N270, wide temperature range CPU, 2GB Internal SSD, 64GB SATA SSD, Windows XP Operating system, AEwin ready, and Ethernet connectivity to a factory network or Internet. 110/220VAC or 9 - 28 VDC power at 30 watts (not including sensor/preamp requirements)</i>	1	\$10,791.00	\$10,791.00
002	<i>PN#9380-2054 , SH-4 AE, 4 channel AE plug-in module for Sensor Highway with 1 MHz AE bandwidth. 4 modules maximum in one Sensor Highway chassis.</i>	2	\$1,574.00	\$3,148.00
003	<i>PN# 9380-7003 , AEwin-SH-16 , "AE win for Sensor Highway Smart Monitor" to 16 channel, full and automated AE data collection, file link, signal and alarm processing and remote communication software.</i>	1	\$2,199.00	\$2,199.00
004	<i>PN# 9800-7110-setup , RMA Setup Charges , PAC Internet monitoring, "Remote Monitoring Application", (RMA) includes any AE system preparations for Remote access here in Princeton, phone/email support once system is delivered, as well as "standard", web hosting account setup charges for opening customer unique, personalized, secure, website. (Other special requests are extra. Consult factory)</i>	1	\$2,625.00	\$2,625.00
005	<i>PN# R15I-LP-AST , R15I-LP-AST, Low Power, Preamplified Sensor, 150kHz, with 26 dB gain, AST, coated for outdoor use, 5 meter coaxial RG-58A/U cable, BNC connector.</i>	8	\$552.00	\$4,416.00
	<b>Subtotal:</b>			<b>\$23,179.00</b>

Item	Model & Description	QTY	Unit Price	Total Price
	<b>16 CHANNELS</b>			
001	<i>PN#9380-5025 , SH-II-SRM</i> , Smart Remote Monitoring, Sensor Highway system is a full, stand-Alone AE system for unattended monitoring in outdoor environments. System Includes; Outdoor case, Sensor Highway 16 channel motherboard (0 channels installed), Atom N270, wide temperature range CPU, 2GB Internal SSD, 64GB SATA SSD, Windows XP Operating system, AEwin ready, and Ethernet connectivity to a factory network or Internet. 110/220VAC or 9 - 28 VDC power at 30 watts (not including sensor/preamp requirements)	1	\$10,791.00	\$10,791.00
002	<i>PN#9380-2054 , SH-4 AE</i> , 4 channel AE plug-in module for Sensor Highway with 1 MHz AE bandwidth. 4 modules maximum in one Sensor Highway chassis.	4	\$1,574.00	\$6,296.00
003	<i>PN# 9380-7003 , AEwin-SH-16</i> , "AE win for Sensor Highway Smart Monitor" to 16 channel, full and automated AE data collection, file link, signal and alarm processing and remote communication software.	1	\$2,199.00	\$2,199.00
004	<i>PN# 9800-7110-setup , RMA Setup Charges</i> , PAC Internet monitoring, "Remote Monitoring Application", (RMA) includes any AE system preparations for Remote access here in Princeton, phone/email support once system is delivered, as well as "standard", web hosting account setup charges for opening customer unique, personalized, secure, website. (Other special requests are extra. Consult factory)	1	\$2,625.00	\$2,625.00
005	<i>PN# R15I-LP-AST , R15I-LP-AST</i> , Low Power, Preamplified Sensor, 150kHz, with 26 dB gain, AST, coated for outdoor use, 5 meter coaxial RG-58A/U cable, BNC connector.	16	\$552.00	\$8,832.00
	<b>Subtotal:</b>			<b>\$30,743.00</b>

**See Cost Breakdown for Optional Equipment on Following Page**

Item	Model & Description	QTY	Unit Price	Total Price
001	PN# 9800-7110-Maint , <b>RMA Yearly Maintance fee</b> , Yearly Remote Monitoring Usage and Maintenance fee. Starts after 1st year.	1	\$1,050.00	\$1,050.00
002	PN# 9380-5065 , <b>Wi-Fi</b> , WiFi wireless Ethernet connectivity from Sensor Highway to BaseStation or BaseStation to Internet. Price is each.	1	\$415.00	\$415.00
003	PN# 9380-5165 , <b>Solar Panel Kit</b> , Stand Alone 520 Watt Solar Power Kit with 4 days of Battery Backup. Includes (4) 130 Watt Solar Panels, (4) 110Ah batteries with enclosure, 45A Charge controller and 400 Watt AC Inverter with enclosure, Pole or Structure monuting hardware. Site Installation Not Included	1	\$9,990.00	\$9,990.00
004	pn# 9380-5035, <b>Cellular Wireless Modem</b> , Wirless 3G modem with remote CPU reset capability. Hardware only. Needs a separate cellular contract provided by customer (For U.S. and Verizon service only).	1	\$1,675.00	\$1,675.00
005	PN# 9380-5045 , <b>SH Battery Backup</b> , Battery Backup option installed into system offers up to 20 minutes operation. (Not needed if you buy Solar Panel Option)	1	\$415.00	\$415.00

Validity: 90 Days  
 Payment Terms: Net 30 days upon approval by Accounting. We also accept credit cards, (VISA, MasterCard Discover & American Express)  
**NOTE: there will be a 3.5% processing fee levied on total of order when using a credit card for orders of \$5000.00 or over.**  
 Delivery: 45-60 Days ARO  
**FOB: Princeton Junction, NJ , Buyer understands that he/she is responsible for shipment, insurance and any damages caused by shipping, from the FOB Shipping Point.**  
 Ship Via: UPS Ground **PP & Add to invoice** or collect with customers account number  
 Origin: Made in USA  
 Minimum Order: \$100  
 Place an Order: Please submit documents to [sales@pacndt.com](mailto:sales@pacndt.com) or by fax to 609-716-0706

I trust that the specifications and options are clear, but if you have any questions or comments, please do not hesitate to call. We appreciate your inquiry and look forward to doing business with you in the near future. If you visit our website at [www.mistrasgroup.com](http://www.mistrasgroup.com) , there is some helpful information on our products.

Best regards,  
*Terry Tamutus*

Terry Tamutus  
 Regional Sales Manager – Northeast  
 Products & Systems Division  
**Mistras Group, Inc.**  
 P: 609-468-5737  
 E: [terry.tamutus@mistrasgroup.com](mailto:terry.tamutus@mistrasgroup.com)



<TAT/eg>

**MISTRAS GROUP INC.**  
**GENERAL TERMS AND CONDITIONS of SALE**

- 1) Acceptance of customer's order is expressly made conditional on assent to the terms and conditions set forth herein and on attachment(s) hereto and they shall constitute the complete agreement between the parties. These terms and conditions may not be varied, or Customer's order terminated in any manner unless by written agreement, with legal consideration, signed by an office of MISTRAS GROUP INC. (also referred to herein as "MISTRAS" or "The Company"). Other representatives of the company are not authorized to vary the conditions herein set forth. Failure to specifically dissent to these terms and conditions or customer's acceptance of any goods covered by this acknowledgment shall constitute acceptance of said terms and conditions and they shall be controlling in every case.
- 2) Unless otherwise specified in writing, all proposals expire ninety (90) days from the date of proposal.
- 3) Unless stated to the contrary on the face hereof, all goods furnished hereunder will be shipped F.O.B. point of shipment, and title in and the right of possession to such goods pass to the customer upon the company's delivery to carrier at point of shipment. Any loss in transit after FOB shipment is the sole responsibility of the customer.
- 4) Unless specified otherwise in writing by MISTRAS, payment terms are net cash, payable without offset, in US dollars, with approved credit, paid 30 days from the date of invoice.
- 5) Purchaser shall pay, in addition to any overdue payment, a late charge of 1.5% per month, on all overdue amounts plus any collection fees, MISTRAS attorney fees and, court costs in connection to collection.
- 6) Tooling, set-up, fitting-up, drawings, design information and partial preparation charges when invoiced cover only part of the cost thereof to the company. The customer does not acquire any right, title or interest in any tooling, set-up, fitting-up, drawings, design information, or invention resulting therefrom.
- 7) Any inspection by the Purchaser of Equipment on MISTRAS premises shall be scheduled in advance and performed during normal working hours.
- 8) On orders where there are partial payments due to MISTRAS based on meeting specific measurable milestones, these invoices/payments represent work completed by MISTRAS and rightfully earned and owned by MISTRAS, without any recourse.
- 9) If the order provides for site acceptance testing to verify that the equipment has arrived at the site complete, without physical damage, and in good operating condition, completion of site acceptance test constitutes full and final acceptance of the equipment. If, through no fault of MISTRAS, acceptance testing is not completed within thirty (30) days after arrival of the equipment at the site, the site acceptance test shall be deemed completed and the equipment shall be deemed accepted and any remaining payments due MISTRAS will be paid by the buyer.
- 10) All shipping dates are tentative. The company will not be responsible for delays of non-performance directly or indirectly caused by governmental regulations or requirements, act of God, unavailability of materials, work stoppages, slow downs, boycotts, and other causes (whether or not similar in nature to any of these hereinbefore specified) beyond the company's reasonable control.
- 11) This company's line of products requires close coordination of the customer's requirements with the company's production schedules to avoid possible delays in shipment. Accordingly, the company reserves the right to ship approximately thirty days in advance of shipping date.
- 12) THERE IS NO WARRANTY BY THE COMPANY THAT THE GOODS SHALL BE DELIVERED free from any claim of any third person by way of infringement of Trademarks, Patents or Copyrights.
- 13) Seller warrants that the articles delivered or used hereunder shall be free from defects in material, workmanship and fabrication. This WARRANTY shall extend for a period of one (1) year after date of delivery of such articles to Buyer. SELLER MAKES NO WARRANTY, EXPRESS, IMPLIED (INCLUDING BUT NOT LIMITED TO WARRANTIES OF MERCHANTABILITY AND FITNESS FOR INTENDED PURPOSE), OR STATUTORY, OTHER THAN THE FOREGOING EXPRESS WARRANTY. Failure of Buyer to submit any claim hereunder within ninety (90) days after receipt of such articles shall be an admission by buyer and conclusive proof that such articles are in every respect as warranted and shall release Seller from any and all claims for damage or loss sustained by Buyer, in the event Buyer timely submits a claim for breach of WARRANTY, the parties agree that Buyer's role and exclusive remedy shall be the repair or replacement of such defective article. IN NO EVENT SHALL SELLER BE LIABLE FOR INCIDENTAL OR CONSEQUENTIAL DAMAGE OF THE PURCHASER, USER OR THIRD PARTIES. Seller's warranties shall inure to the benefit of the original user only.
- 14) Factory service by personnel from the United States for loaned or purchased items, if required, is available at a charge of prevailing labor rate per man-day, plus expenses and parts. Spare and replacement parts for the tool(s), and/or machine(s), and/or applicator(s), can be purchased from the company.
- 15) The company shall have the right to suspend or cancel this agreement at any time upon customer making an assignment for the benefit of creditors or becoming bankrupt or insolvent, or upon a petition being filed in a court of competent jurisdiction proposing

the appointment of a receiver or that the customer be adjudicated bankrupt or insolvent or reorganized under the provisions of any applicable bankruptcy or insolvency act.

- 16) The company represents that with respect to the production of the articles and/or the performance of the services stated herein, it has fully complied with all the applicable provisions of the Fair Labor Standards Act of 1938, as amended, including section 6, 7 and 12, regulations under section 14, and all other applicable Administrative Regulations.
- 17) Any order may be cancelled before shipment by Purchaser only upon written notice and payment of termination charges, including but not limited to, all costs identified to the order incurred prior to the effective date of notice of termination and all expenses incurred by MISTRAS attributable, plus a fixed sum of fifteen (15) percent of the final total price to compensate for disruption in scheduling, planned production and other indirect costs.
- 18) MISTRAS warrants that, except as specified below, the software will, when properly installed, execute in accordance with MISTRAS's specification. If a nonconformity to the foregoing warranty is discovered during the period ending one (1) year after date of shipment and written notice of such nonconformity is provided to MISTRAS promptly after such discovery and within that period, including a description of the nonconformity and complete information about the manner of the discovery, MISTRAS shall correct the nonconformity by, at its option, either (i) modifying or making available to the Purchaser instructions for modifying the Software, or (ii) making available at MISTRAS's facility necessary corrected or replacement programs. MISTRAS shall have no obligation with respect to nonconformities resulting from (i) unauthorized modification of the Software or (ii) Purchaser-supplied software or interfacing. MISTRAS does not warrant that the functions contained in the software will operate in combinations which may be selected for use by the Purchaser, or that the software products are free from errors in the nature of what is commonly categorized as "bugs". MISTRAS owns all rights in or has right to sublicense all of the software, if any, to be delivered to Purchaser under this Agreement. As part of this sale made hereunder Purchaser hereby obtains a limited license to use Software, subject to the following: (i) The software may be used only in conjunction with Equipment specified or approved by MISTRAS, (ii) The software shall be kept strictly confidential, (iii) The software shall not be copied, reverse engineered, or modified, (iv) the Purchaser's right to use the software shall terminate immediately when specified equipment is no longer used by the Purchaser or when otherwise terminated and (v) the rights to use the software are non-exclusive and non-transferrable, except with MISTRAS prior written consent.
- 19) In addition to the rights and remedies reserved herein, the company shall have all rights and remedies conferred by law and shall not be required to proceed with performance for the contract arising herefrom if customer is in default to the company under this or any other contract. This agreement shall be construed in accordance with the laws of the State of New Jersey, U.S.A.
- 20) The prices stated in this acknowledgment do not include, unless specifically stated, any special processing charges (e.g. Letters of Credit, wire transfer fee's, bank fee's, etc.), credit card charges, sales, use or other taxes and if such are payable in connection with this order they shall become an additional charge to the Purchaser.
- 21) In no event shall MISTRAS, its suppliers or subcontractors be liable for special, indirect, incidental, or consequential damages, whether in contract, warranty, tort, negligence, strict liability or otherwise, including, but not limited to, loss of profits or revenue, loss of use of the equipment or any associated equipment, cost of capital, cost of substitute equipment, facilities or services, downtime costs, delays, and claims of customers of the Purchaser or other third parties for any damages. MISTRAS liability for any claim whether in contract, warranty, tort, negligence, strict liability, or otherwise for any loss or damage arising out of, connected with, or resulting from this agreement or the performance or breach thereof, or from the design, manufacture, sale, delivery, resale, repair, replacement, installation, technical direction of installation, inspection, operation or use of any equipment covered by or furnished under this agreement, or from any services rendered in connection therewith, shall in no case exceed on-half (1/2) of the purchase price allocable to the equipment or part thereof or services which gave rise to this claim.
- 22) This sales order acknowledgment constitutes SELLER'S offer to BUYER upon the terms and conditions stated herein and shall become a binding contract on the terms set forth herein when it is accepted by BUYER either by acknowledgment or by acceptance of the goods sold hereunder. By acceptance of the goods referred to herein BUYER thereby understands and agrees that SELLER will not and need not analyze any of the terms, conditions and other provisions contained in BUYER'S purchase order other than to determine the product or service ordered, quantities and shipping data. BUYER also agrees that SELLER may disregard all terms, conditions and provisions of any such purchase order that do not comply herewith and may fulfill such part of the terms, conditions, and provisions thereof as shall comply herewith. Any variation of the terms and conditions herein must be specifically accepted in writing by SELLER.