



RESEARCH
SERVICES SECTION

TECHNICAL SUMMARY

Technical Liaison:

Jim Pierce, Mn/DOT
james.pierce@dot.state.mn.us

Administrative Liaison:

Alan Rindels, Mn/DOT
alan.rindels@dot.state.mn.us

Principal Investigator:

Arturo Schultz, University of Minnesota

PROJECT COST:

\$55,000

Incorporation of Fatigue Detail Classification of Steel Bridges into the Mn/DOT Database

What Was the Need?

Mn/DOT is responsible for approximately 1,100 steel bridges across the state, approximately 975 of which were built before 1990. Numerous construction practices that were common prior to the 1990s have necessitated subsequent repairs or special retrofits; these practices have consequently been eliminated by changes in code. Many of these bridge upgrades involved adding features to strengthen the bridge after construction. Some of these “details” where the improvement was made are especially susceptible to fatigue and cracking. Monitoring these details is part of the general maintenance and inspection protocol for all steel bridges.

Mn/DOT also routinely receives requests to raise the load limits on its trunk highway bridges. To evaluate these requests and effectively use financial and personnel resources, Mn/DOT needs dependable, straightforward tools to help in establishing priorities. An earlier research project, “Effects of Increasing Truck Weight on Steel and Prestressed Bridges” (2003-16), found that fatigue of the details of steel bridges is the primary mechanism for deterioration. In that study, researchers attempted to collect information about all bridges and analyze the entire group for fatigue effects in light of requests for increased load limits. Such broad-based classification proved very difficult to implement for a large network of bridges, and Mn/DOT engineers concluded that the scope of the analysis should be narrowed to include only those bridges with fatigue-prone details.

Reducing the scope of the classification and ranking to an important subset of details, namely those that bear on the fatigue and cracking steel bridges, should allow Mn/DOT to better target its improvement efforts to those bridges that need the most attention and to better evaluate requests for load-limit increases.

What Was Our Goal?

This project was initiated to:

- Develop criteria utilizing known or easily obtainable quantitative measures for assessing steel bridge fatigue problems.
- Establish a rating scheme to aid in ranking the fatigue susceptibility of steel girder bridges.
- Produce an analysis tool that can help direct Mn/DOT to those bridges in the most need of closer scrutiny.

What Did We Do?

Researchers reviewed the relevant literature and collected case studies on cracking and predictive formulas for assessing fatigue in steel bridges. From this information, they compiled a list of details that are prone to cracking problems and categorized these details according to geometric properties using information gathered from codes, case studies and prior experience. Researchers consulted design plans and inspection reports from a selection of Minnesota bridges and surveyed 15 state transportation departments, gathering data on the occurrences of cracking in steel bridges.

In consultation with Mn/DOT engineers, researchers generated a comprehensive table containing 18 distinct bridge details, supplying descriptions and pictures to facilitate their identification. Among the bridge details classified were the stringer floor-beam

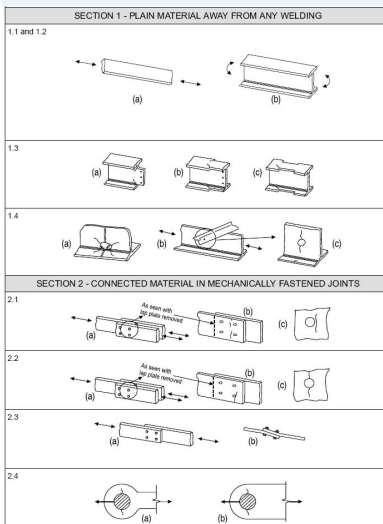

The project used AASHTO classification schemes for fatigue-susceptible details.

“The districts are handling maintenance and inspections well. This ranking tool provides more information to us in the bridge office, helping us start with what’s important in considering safety, inspections and load-increase requests.”

–Jim Pierce,
Mn/DOT Bridge
Management Engineer

“This report may be used for the identification of details requiring special attention during inspections.”

–Arturo Schultz,
Professor, University of
Minnesota Department
of Civil Engineering

Produced by CTC & Associates for:

Minnesota Department
of Transportation
Research Services Section
MS 330, First Floor
395 John Ireland Blvd.
St. Paul, MN 55155-1899
(651) 366-3780
www.research.dot.state.mn.us

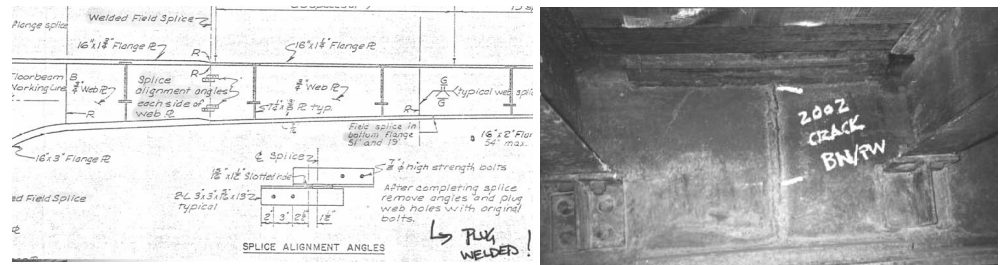

The data regarding each of the details that forms the input to the ranking is obtained by comprehensive examination of bridge plans and notes from inspections.

Cracking, field-welded splices and insufficient cope radius of steel cuts. Among the factors contributing to the classification itself were the rapidity of cracking and the sensitivity of the placement of the bridge detail on the bridge structure. The rankings of each detail are qualitative, employing a scale from “0 - No Issues” to “4 - High Consequence of Cracking.” Researchers wrote an Excel spreadsheet-based program implementing the ranking system. The program generates a composite rank number based upon the distribution and rank of the individual details in the bridge.

What Did We Learn?

The primary goal of this project was accomplished: The study established criteria for the evaluation of fatigue in steel bridges that are easily usable by Mn/DOT.

Researchers noted that the problems of cracking in steel bridges with fatigue-prone details will disappear over time because many of the problematic details have been eliminated from the code.

Researchers also noted that while the composite rank provides a good guide as to which bridges are the most problematic, this ranking involves aggregating information, and some subtleties of the component data may be lost. The data table used to produce these rankings is itself a general tool that gives engineers and researchers the flexibility to explore alternative composite rankings that would emphasize other characteristics. Exploration of such rankings may aid in evaluating maximum loading or requests for load rating changes.

What’s Next?

An [implementation project](#) was completed in late 2008 that involved compiling data for and ranking the entire Minnesota bridge inventory. This enables statistical analysis of the inventory and offers Mn/DOT tools to proactively identify bridges most likely to fatigue and details that require special attention during inspections. The rank data and other bridge details documented during the implementation are expected to be uploaded and stored in the Pontis Bridge Management System, which Mn/DOT uses to manage bridge maintenance, by summer 2009.

This Technical Summary pertains to Report 2007-22, “Incorporation of Fatigue Detail Classification of Steel Bridges into the Minnesota Department of Transportation Database,” published June 2007. The full report can be accessed at <http://www.lrrb.org/PDF/200722.pdf>.

The subsequent implementation project, MPR-6(036), “Implementation of Steel Bridge Maintenance Planning,” completed in December 2008, is described in Technical Summary 2007084, which can be accessed at <http://www.lrrb.org/PDF/2007084TS.pdf>.