



# Construction Report for a Thin Unbonded Concrete Overlay on Minnesota TH 53

Minnesota  
Department of  
Transportation

**RESEARCH  
SERVICES**

Office of  
Policy Analysis,  
Research &  
Innovation

Mark Watson, Primary Author  
Minnesota Department of Transportation

**July 2010**

Research Project  
Interim Report #2010-23

**MnROAD**  
Office of Materials

*Your Destination... Our Priority*



## Technical Report Documentation Page

1. Report No. MN/RC 2010-23	2.	3. Recipients Accession No.	
4. Title and Subtitle Construction Report for a Thin Unbonded Concrete Overlay on Minnesota TH 53		5. Report Date July 2010	
		6.	
7. Author(s) Mark Watson, Erland Lukanen, Steven C. Olson, Thomas R. Burnham		8. Performing Organization Report No.	
9. Performing Organization Name and Address Minnesota Department of Transportation Office of Materials and Road Research 1400 Gervais Avenue Maplewood, MN 55109		10. Project/Task/Work Unit No.	
		11. Contract (C) or Grant (G) No.	
12. Sponsoring Organization Name and Address Minnesota Department of Transportation Research Services Section 395 John Ireland Boulevard, Mail Stop 330 St. Paul, MN 55155		13. Type of Report and Period Covered Interim Report	
		14. Sponsoring Agency Code	
15. Supplementary Notes <a href="http://www.lrrb.org/pdf/201023.pdf">http://www.lrrb.org/pdf/201023.pdf</a>			
16. Abstract (Limit: 250 words)  <p>Unbonded concrete overlays are generally used to rehabilitate pavements by restoring lost ride and structural capacity. Historically, their design has been conservative (thick) due to the lack of a rational design method. In the summer of 2008, TH 53 near Duluth, MN, was rehabilitated with a thin (5-inch thick) unbonded concrete overlay. The Minnesota Department of Transportation (Mn/DOT) included the TH 53 overlay as part of a research project on thin unbonded concrete overlays. Falling weight deflectometer (FWD) measurements were taken both before and after construction. A short section of the project was instrumented with electronic sensors designed to collect environmental and load response data.</p> <p>The TH 53 test section is currently undergoing thorough evaluations and rigorous testing in accordance with the research project work plan. This report presents the initial baseline testing results, which include: distress survey and mapping, ride quality measurements, and structural testing. A visual distress survey, conducted in April 2009, revealed that approximately 40 transverse cracks have formed in the overlay over the nearly nine mile project length. FWD measurements indicate that the new pavement is providing good structural support.</p>			
17. Document Analysis/Descriptors Concrete pavements, Concrete overlays, Thin Unbonded Concrete Overlay, Pavement Performance, Pavement Instrumentation		18. Availability Statement No restrictions. Document available from: National Technical Information Services, Springfield, Virginia 22161	
19. Security Class (this report) Unclassified	20. Security Class (this page) Unclassified	21. No. of Pages 47	22. Price

# **Construction Report for a Thin Unbonded Concrete Overlay on Minnesota TH 53**

## **Interim Report**

*Prepared by:*

Mark J. Watson  
Erland Lukanen  
Steven C. Olson  
Thomas R. Burnham

Office of Materials and Road Research  
Minnesota Department of Transportation

**July 2010**

*Published by:*

Minnesota Department of Transportation  
Research Services Section  
395 John Ireland Boulevard, MS 330  
St. Paul, Minnesota 55155-1899

This report represents the results of research conducted by the authors and does not necessarily represent the views or policies of the Minnesota Department of Transportation. This report does not contain a standard or specified technique.

The authors and the Minnesota Department of Transportation do not endorse products or manufacturers. Any trade or manufacturers' names that may appear herein do so solely because they are considered essential to this report.

## **Acknowledgements**

The authors would like to thank the following Minnesota Department of Transportation employees, whose activities and contributions were instrumental to the successful construction and material testing of the TH 53 thin unbonded concrete overlay test section:

Mn/DOT District 1 construction and soils staff, Shafer Contracting, Inc., Mn/DOT Materials and Road Research staff members: Bev Baron and Greg Larson (FWD testing), Bob Strommen (Electronic Sensors and Load Testing), and John Pantelis (Research Technical Support).

## Table of Contents

<b>Chapter 1. Introduction .....</b>	<b>1</b>
Miller Trunk Highway (TH 53) .....	1
Objectives of Report and Research .....	1
State of the Practice .....	2
Construction Contract .....	2
<b>Chapter 2. Instrumentation and Data Collection .....</b>	<b>3</b>
Instrumentation .....	3
Data Collection System Layout .....	6
<b>Chapter 3. Design, Construction and Materials .....</b>	<b>7</b>
Existing Conditions (Prior to Overlay Placement) .....	7
TH 53 Overlay Description & Design .....	10
Construction Sequence .....	13
Material Sampling and Testing .....	14
<b>Chapter 4. Pavement Structural Testing and Analysis .....</b>	<b>16</b>
Falling Weight Deflectometer (FWD) .....	16
Structural Testing Conclusions .....	22
<b>Chapter 5. Pavement Surface Testing and Evaluation .....</b>	<b>23</b>
Ride Quality Measurements .....	23
Distress Surveys .....	24
<b>Chapter 6. Conclusions .....</b>	<b>30</b>
Recommendations .....	30
<b>References .....</b>	<b>31</b>
<b>Appendix A. Documentation of Early Distresses</b>	

## List of Figures

Figure 1.1. TH 53 Project Location .....	1
Figure 2.1. Location of Cell 53-1 on TH 53 .....	3
Figure 2.2. Cell 53-1 Instrumentation and Data Collection System Layout.....	4
Figure 2.3. Dynamic Strain Sensors [Left] and Environmental Strain Sensors [Right].....	5
Figure 2.4. Installed Instrumentation Prior to Paving the Overlay [September 9, 2008] .....	5
Figure 2.5. Completed Data Collection System.....	6
Figure 3.1. SP 6916-41 Soils Letter .....	7
Figure 3.2. Mainline Typical Sections for 1972 TH 53 Project.....	8
Figure 3.3. Reinforced Concrete Pavement Detail for 1972 TH 53 Project .....	8
Figure 3.4. Typical Transverse and Longitudinal Joint Condition Prior to Overlay .....	9
Figure 3.5. Average Pavement Condition Prior to Overlay .....	10
Figure 3.6. Cross-Section of TH 53 Overlay (9) .....	11
Figure 3.7. TH 53 Thin Unbonded Concrete Overlay, September 2008 .....	13
Figure 4.1. Routine FWD Testing Locations in Test Cell 53-1 .....	16
Figure 4.2. SLIC Check of Mid-Panel Deflection Data.....	17
Figure 4.3. Comparison of EverCalc Calculated Deflections and the Measured Deflection .....	18
Figure 4.4. Average Deflection Basin when the Load Plate is Before the Joint.....	19
Figure 4.5. Average Deflection Basin when the Load Plate is After the Joint .....	20
Figure 4.6. Comparison of the Deflections by Distance from Center of Slab .....	21
Figure 5.1. LISA [Left] and Pavement Management Van [Right] .....	23
Figure 5.2. From Left to Right: High (3), Medium (2) and Low (1) Severity Cracking .....	24
Figure 5.3. TH 53 Distress Map [Midway Rd to Solway Rd], April 2009.....	25
Figure 5.4. TH 53 Distress Map [Solway Rd to Caribou Lake Rd], April 2009 .....	26
Figure 5.5. TH 53 Distress Map [Caribou Lake Rd to Munger Shaw Rd], April 2009.....	27
Figure 5.6. TH 53 Distress Map [Munger Shaw Rd to Tuhkanen Dr.], April 2009.....	28
Figure 5.7. TH 53 Distress Map [Tuhkanen Dr. to Industrial Rd], April 2009 .....	29

## **List of Tables**

Table 2.1. Sensor Types and Quantities for Cell 53-1 .....	5
Table 3.1. RQI Categories and Ranges (5) .....	9
Table 3.2. Concrete Grade Classification (6).....	12
Table 3.3. Concrete Slump Classification (6).....	12
Table 3.4. Concrete Mix Gradation Classification (7).....	12
Table 3.5. Bituminous Gradation Broadband Requirements (8) .....	13
Table 3.6. TH 53 Flexural Beam Strength Test Results .....	14
Table 3.7. TH 53 Cylinder Compressive Strength Test Results .....	15
Table 4.1. Backcalculated Layer Moduli .....	18
Table 4.2. TH 53 Average Deflections at a Given Load and Location (Prior to Overlay).....	21
Table 5.1. Ride Results for: LISA [Left] and Pavement Management [Right] - 2009.....	23

## Executive Summary

Unbonded concrete overlays are generally used to restore lost ride quality and/or add structural capacity to older concrete pavements. Due to the lack of a rational design method, these overlays have historically had rather thick surface layers (greater than 7 inches). The thick concrete layer results in higher initial costs than competing alternatives. In an effort to reduce initial costs and optimize the use of natural resources, TH 53 near Duluth, MN, was rehabilitated in 2008 with a thin (5 inch surface thickness) unbonded concrete overlay (TUBOL). Coincidentally, the Minnesota Department of Transportation (Mn/DOT) was conducting a research study titled “Performance of Thin Unbonded Concrete Overlays on High Volume Roads.” That study includes monitoring the performance of several thin unbonded concrete overlay sections at the Minnesota Road Research (MnROAD) facility. With several design features significantly different than the MnROAD sections, it was decided to add the TH 53 project into the research study.

TH 53 was originally constructed in 1972, and consisted of an 8-inch thick reinforced concrete pavement with 27-foot long panels and a 6 inch thick Mn/DOT class 5 aggregate base. The pavement had been restored twice using standard concrete pavement repair (CPR) techniques. By 2007 however, pavement management records indicated the pavement condition had deteriorated to a “fair condition”.

Construction of the thin unbonded concrete overlay (fall 2008) involved minimal preparation of the existing surface. The pavement surface was swept clean and loose pieces of concrete were removed. The potholes, deteriorated joints and other depressions were filled in with a variable thickness (1 inch minimum) dense graded bituminous interlayer. The 5 inch thick concrete overlay was placed quickly with a slipform paver. The concrete slabs were cut to form panels 12 feet long by 12 feet wide, except for a small number of panels cut to a size of 6 feet long by 6 feet wide. Electronic sensors, designed to collect environmental and load response data, were installed into two panels of the 9+ mile project. Data from the sensors will be used to create or improve design methods for thin unbonded concrete overlays.

Supplementary material samples were taken for additional characterization of the concrete mix used in the project. Falling weight deflectometer (FWD) testing was performed to measure slab deflection and joint load transfer efficiency both prior to and following construction of the overlay. Baseline ride quality measurements were made in 2009, and will be periodically taken as the study progresses.

Several visual distress surveys have documented approximately 40 transverse cracks that have formed in the 9 + mile overlay. These cracks had severity ratings in August 2009 of: 7% high, 41% medium, and 51% low. Due to the thinner surface layer, the paving process progressed rapidly, and the high surface to thickness ratio increased the challenge of predicting joint formation times.

Performance of the TH 53 test section will continue to be monitored and compared to the MnROAD test sections. The data from both projects will be used toward the development of improved distress and life prediction models. These models will ultimately be used in the development of mechanistic-empirical design methods for thin unbonded concrete overlays.



## Chapter 1. Introduction

### Miller Trunk Highway (TH 53)

TH 53 is officially classified as a principal arterial road and identified as a medium priority interregional corridor; this roadway extends from Duluth to International Falls, Minnesota. In the summer/fall of 2008 the Minnesota Department of Transportation (Mn/DOT) District 1 (Duluth/Virginia) undertook a rehabilitation project (SP 6916-99) on the southbound lanes of Minnesota Trunk Highway (TH) 53 from 0.1 miles south of County State Aide Highway (CSAH) 13 (RP 12.598) to 0.9 miles north of CSAH 8 (RP 21.895), see Figure 1.1. This project involved constructing a 5-inch thick jointed plain concrete pavement layer over a variable depth (1 inch minimum) dense graded bituminous interlayer over the existing, deteriorated concrete pavement. The cross-slope (crown) of the pavement was changed from .01 (ft/ft) to .02 (ft/ft) using the variable depth bituminous interlayer.

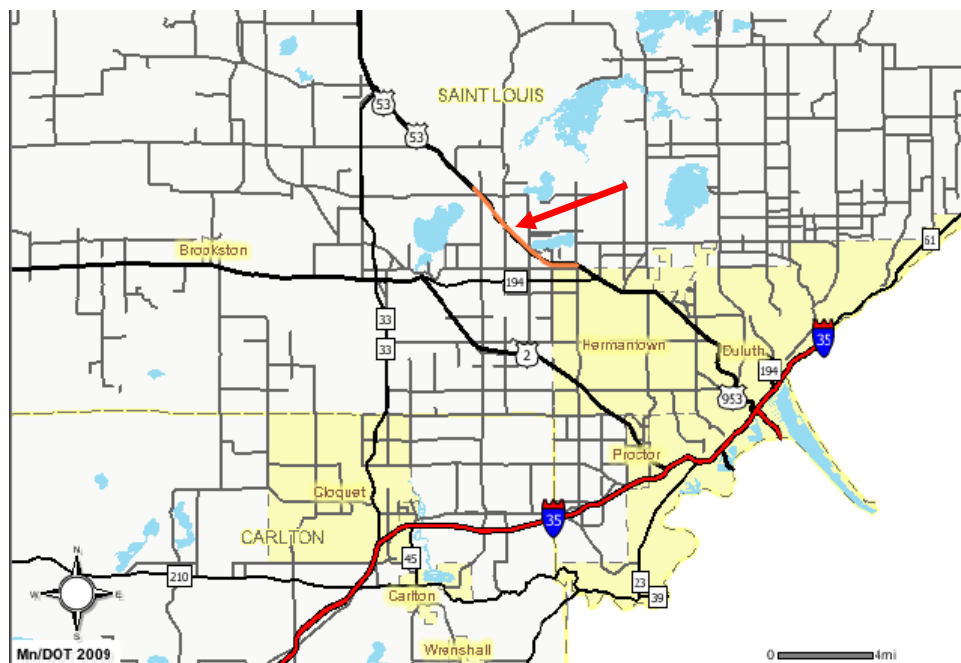

Figure 1.1. TH 53 Project Location

At approximately the same time as the TH 53 project, the Minnesota Road Research (MnROAD) facility was undergoing Phase II reconstruction projects. Original MnROAD Cell 5 also received thin unbonded concrete overlay sections with either a 4 or 5-inch surface thickness. These sections were constructed over a 1-inch thick permeable asphalt stabilized stress relief course (PASSRC) interlayer (1). The MnROAD project also involved a cross-slope correction from .015 (ft/ft) to .020 (ft/ft), however it is unclear from design records, whether the correction was made in the PASSRC or concrete layer.

### Objectives of Report and Research

The TH 53 project was constructed as a rehabilitation effort by Mn/DOT District 1, and only differs from other rehabilitation projects in that it contains an instrumented test cell and a more rigorous monitoring and evaluation program than typical Mn/DOT projects. This report will outline the research effort and document the test cell layout and construction, pavement design,

sensor types and locations, mix design, and material testing. It will also summarize the early monitoring efforts and pavement performance. The research objectives for the TH 53 study include:

- Construct, instrument and monitor a thin unbonded concrete overlay subjected to live traffic.
- Facilitate the measurement of performance data to improve the understanding of thin unbonded concrete overlays, especially with regard to: maturity, slab warp and curl, thermal expansion, and repair techniques. This data will be used in the development of better distress and life prediction models.
- Provide possible design recommendations and changes to Mn/DOT standard specifications, special provisions, and manuals for constructing thin unbonded concrete overlays.

### **State of the Practice**

Mn/DOT currently designs and constructs a large number of unbonded PCC overlays (UBOL) and has experienced good to excellent performance from these projects (2). Standard Mn/DOT UBOL practice involves the use of a one inch thick drainable HMA stress relief (PASSRC) interlayer, and a concrete layer thickness of at least 7, but usually 8 to 9 inches.

NCHRP Synthesis Report No. 415 (3) (Evaluation of Unbonded Portland Cement Concrete Overlays) consisted of a literature review, a survey of state highway agencies, and results from the analysis of data from the Long Term Pavement Performance (LTPP) database, in an attempt to establish a relationship between site conditions, design parameters, and overlay performance. The report noted some general characteristics that contributed to good UBOL performance, such as: overlay slab thicknesses of at least 7 in., a bituminous interlayer at least 1 in. thick, and doweled joints. Similar to Mn/DOT, other agencies have historically used unbonded concrete overlay thicknesses of 7.5 to 8 inches over a 1 – 2-inch thick HMA interlayer. The drainable bituminous interlayer has historically had good performance in Minnesota, however it costs more to produce than standard dense graded HMA interlayers. The TH 53 represents a dramatic cost savings (in terms of initial, or first cost) from traditional UBOL in the following: less PCC material (which can be paved faster), no dowels, larger panel sizes (12-foot long x 12-foot wide) and dense graded bituminous interlayer (lower cost than PASSRC and doesn't require edge drains).

A literature review conducted for the MnROAD TUBOL sections (4) concluded that the current design and instrumentation of the TH 53 thin UBOL test cell will incorporate both proven design and construction techniques, as well as new experimental features that will help to advance the state of the practice of thin unbonded concrete overlays. This project will either validate current design thicknesses, or provide evidence that current practices are overly conservative.

### **Construction Contract**

This project (Mn/DOT state project number: S.P. 6916-99) was more than 9.3 miles long and included grading, concrete and bituminous surfacing, drainage work and bridge repair (Br. No. 69061). This project was let on June 11, 2008 and awarded to Shaffer Contracting Co, Inc. of Shaffer, MN for the amount of \$5,369,558.58.

## Chapter 2. Instrumentation and Data Collection

### Instrumentation

An important component of the TH 53 study was the installation of instrumentation to monitor the environmental and load responses of the pavement. This was accomplished in a short test section (designated as cell 53-1), which also serves as a location for semi-annual ride quality measurements, dynamic load response testing, falling weight deflectometer (FWD) testing, and detailed distress evaluations.

Test cell 53-1 is located between Midway Road (St. Louis County Rd. 13, RP 12.728) and Solway Road (St. Louis County Rd. 889, RP 13.665) at station No. 455 in the driving (right) lane of south bound TH 53 (Figure 2.1).

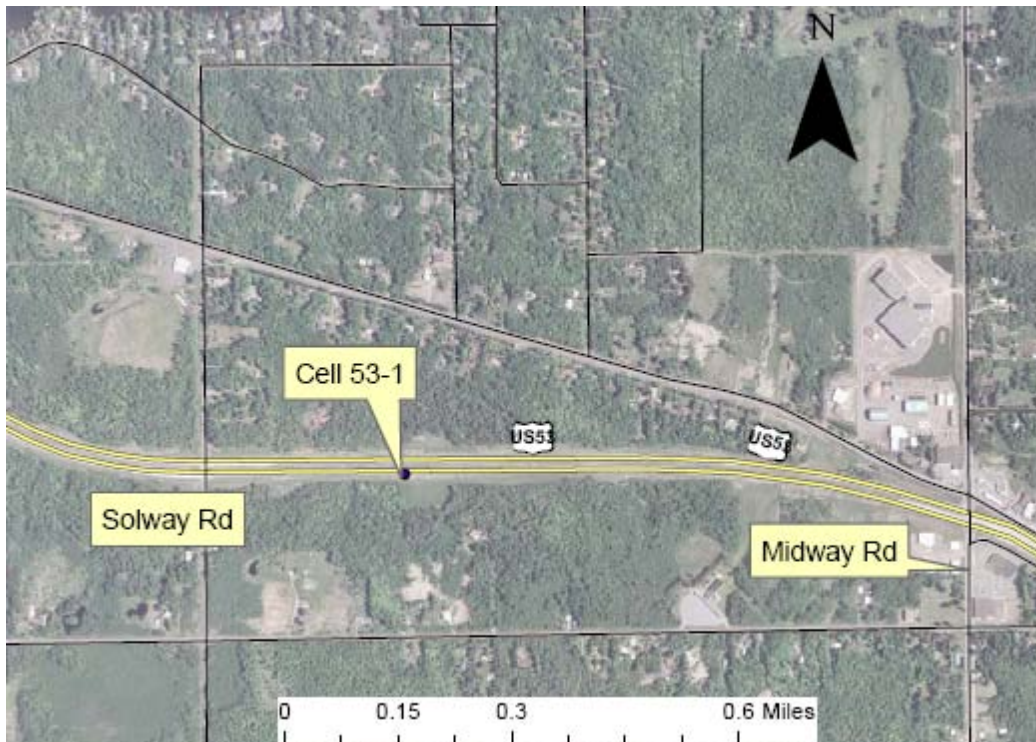

Figure 2.1. Location of Cell 53-1 on TH 53 (Farm Service Agency, 2002)

Figure 2.2 shows the as-built sensor layout. Note that “T” or “B” denotes a sensor embedded near the top or bottom of the slab, respectively. The 2-inch diameter electrical conduits (for routing sensor leads to the roadside data collection equipment) were placed approximately 12-inch below the ground surface. The data collection tower receives electrical power from a battery, which is recharged with a solar powered panel.

The electronic sensors were embedded within the pavement structure at varying depths to measure the pavement’s response to load and environmental effects. Figure 2.3 shows sensors secured to wooden dowels prior to concrete overlay placement. Note that wooden dowels were used in an effort to minimize any reinforcing effects to the pavement slab.

Figure 2.4 shows the instrumentation configuration prior to the placement of the concrete overlay. Note the dashed white paint markings denote approximate saw cut locations that will form the transverse joints of the 12-foot long by 12-foot wide panel. This is important, as sensor placement within a concrete panel influences the measurements.

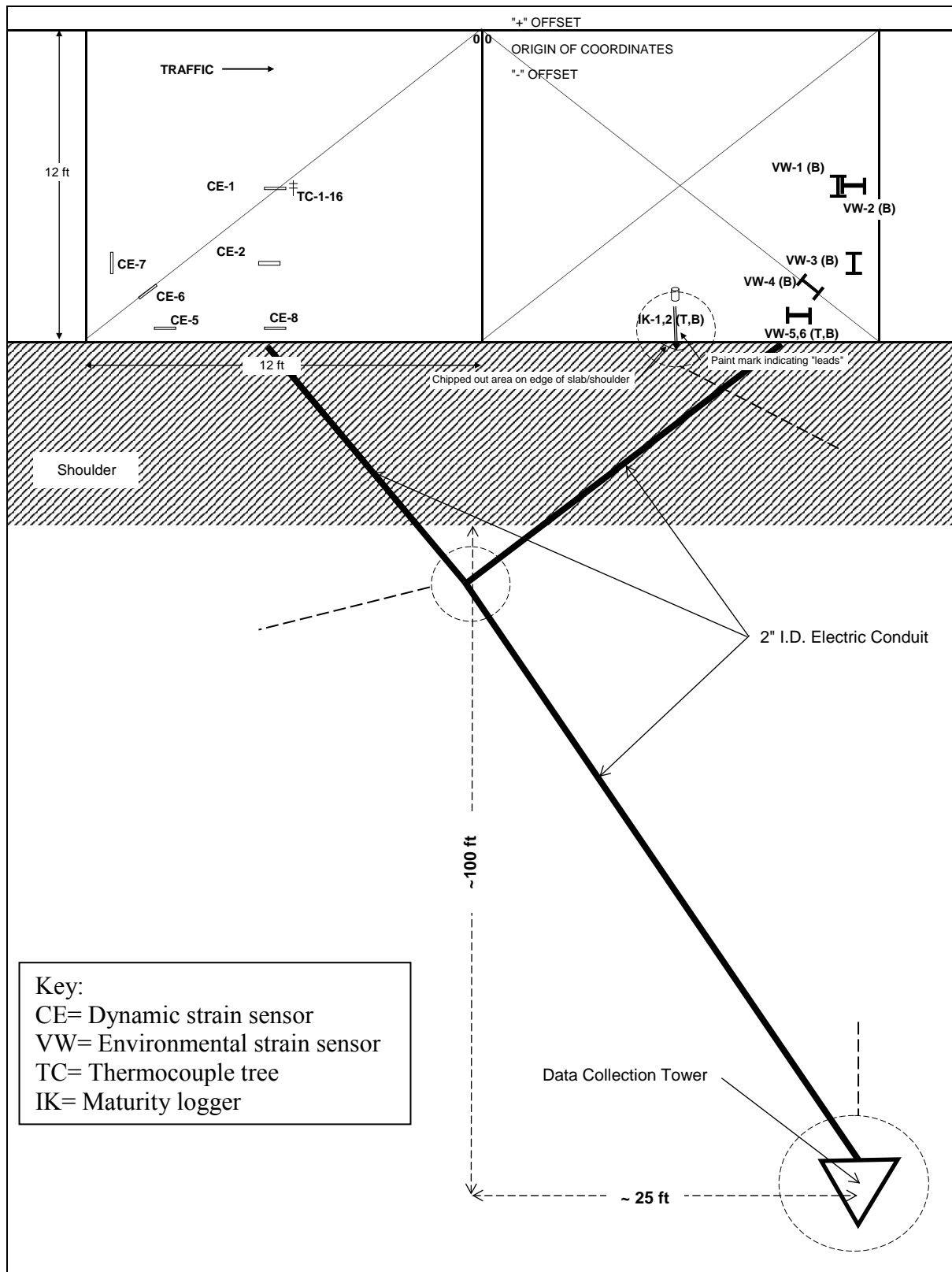

Figure 2.2. Cell 53-1 Instrumentation and Data Collection System Layout



Figure 2.3. Dynamic Strain Sensors [Left] and Environmental Strain Sensors [Right]



Figure 2.4. Installed Instrumentation Prior to Paving the Overlay [September 9, 2008]

To minimize the impact from the concrete paving process, fresh concrete was hand packed and vibrated around the sensors as the paver approached. The vibrators of the paver were raised in the vicinity of the sensors to prevent damage to the sensors.

Table 2.1 summarizes the type and number of operating sensors in each of the new cells. For further information on installation techniques, please contact the Road Research Section in the Mn/DOT Office of Materials and Road Research.

Table 2.1. Sensor Types and Quantities for Cell 53-1

Sensor Code	Sensor Type	Manufacturer	Measurement Type	Number of sensors
CE	PML-60-20	Tokyo Sokki	Dynamic Strain	6
TC	Thermocouple (T-Type)	Omega	Temperature	16
VW	4200 Vibrating Wire	Geokon	Environmental Strain	6

### Data Collection System Layout

A National Instruments data acquisition unit is used to collect strain data from the dynamic sensors, and a Campbell Scientific CR23X datalogger is used to collect temperature and strain data from the environmental sensors. Figure 2.5 shows the completed data collection system.

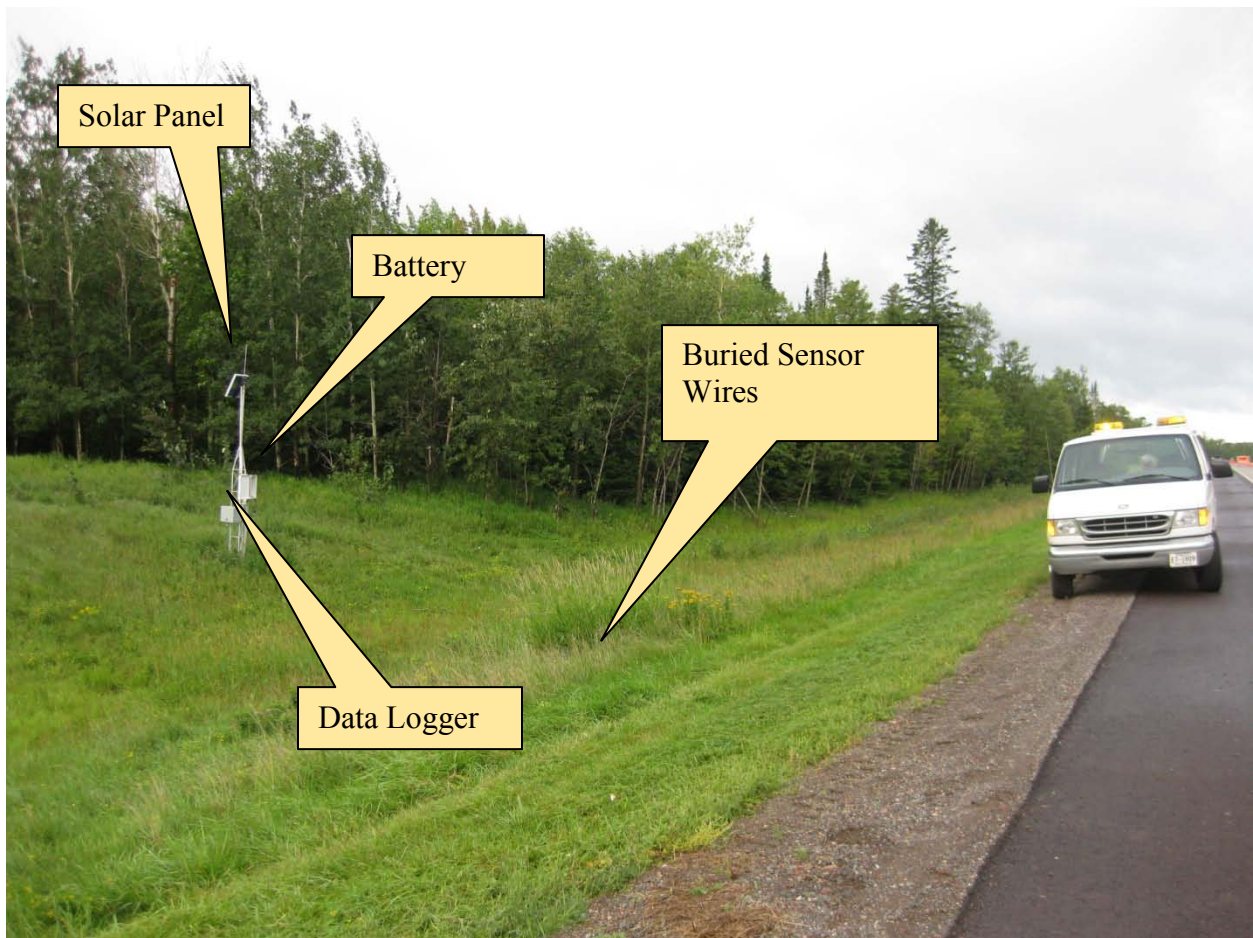

Figure 2.5. Completed Data Collection System

## Chapter 3. Design, Construction and Materials

### Existing Conditions (Prior to Overlay Placement)

This facility is a 4 lane divided highway with at grade crossings. The 2006 Average Annual Daily Traffic (AADT) was 12,300, with 580 Heavy Commercial Average Daily Traffic (HCADT) near CSAH 13 on the south end of the project and 7,900 AADT with 180 HCADT near CSAH 8 on the north end of the project.

A soils letter from SP 6916-41 (1963) documents the soils present in the project area as shown in Figure 3.1 below.

TO: D. T. Burns, Road Design Engineer Date 1-30-63  
 FROM: Materials and Research Section F. E. Friedrichson  
 SUBJECT: Data for Preliminary Estimates  
Soils, Aggregates, and Surfacing

Surface Type: Rigid  
 S.P. 6916-41 T.H. 53 Sta. 412 to 998 Length: 10.8 Mi. or 16.61 Mi.  
of 1/2 of 4 lane.  
 Location: Between CSAH 13 and 0.3 Mi. South of T.H. 33.  
 Traffic and Design Loading: 9T 6-1100 HCADT / 5-10000 ADT

Tentative Section:		FA	CA
<u>8" Concrete Pavement</u>		<u>30586T</u>	<u>58882T</u>
<u>3" Class 5</u>			<u>63550T</u>
<u>1 1/2" 2331 Shoulder with filler</u>			<u>8837T</u>
<u>Class 5 Shoulder base</u>			<u>41443T</u>
<u>Subbase Sections #1 &amp; 2</u>		<u>Section #3</u>	
	<u>3" Cl. 4</u>		<u>54029T</u>
	<u>3" Select Sand</u>		<u>9453 C.Y.</u>
	<u>9" Sand (Cl. "A" Pricing)</u>		<u>31028 C.Y.</u>
<u>General Soils: Red drift. #1-Sta. 412-510, Sta. 655-785, 845-998 - Sandy Loam</u>			
<u>#2 Sta. 510-530, 585-655 - Silt Loam. #3-530-585, Sta. 785-845 - Sand &amp; Gravel.</u>			
<u>2100' of Swamp 10-15' deep. 2500' Swamp 3-5' deep.</u>			

Figure 3.1. SP 6916-41 Soils Letter

The original roadway was graded under SP 6916-57 in 1971 and paved under SP 6916-59 in 1972. The construction plans for the paving project showed mainline typical sections consisting of 8-inch reinforced concrete pavement with doweled, 2-foot skewed, 27-foot spaced contraction joints over 6-inch of Mn/DOT class 5 aggregate base. See Figure 3.2 and Figure 3.3.

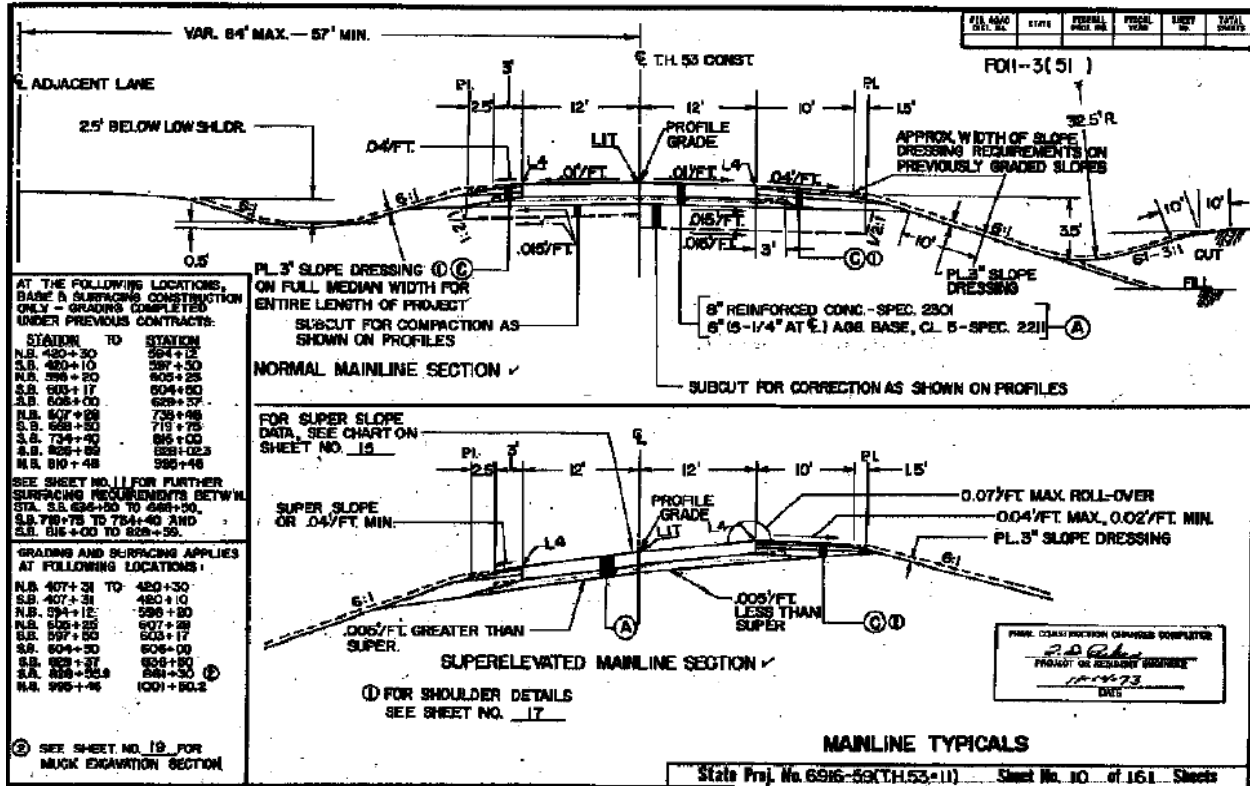

Figure 3.2. Mainline Typical Sections for 1972 TH 53 Project

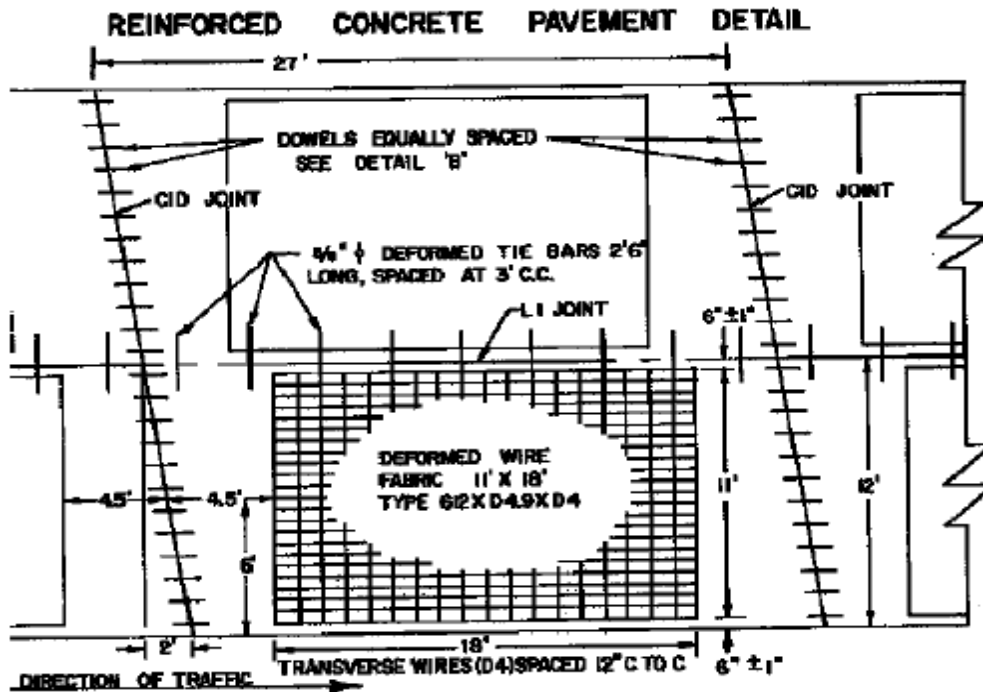

Figure 3.3. Reinforced Concrete Pavement Detail for 1972 TH 53 Project



Prior to overlay construction, the pavement had received two concrete pavement repair (CPR) operations, which included joint sealant removal and replacement in 1983 and joint repair in 1992. Figure 3.4 shows transverse and longitudinal joint condition prior to overlay placement in 2008 (note that the repair treatments are still visible). Some joints had deteriorated down to the base material.



Figure 3.4. Typical Transverse and Longitudinal Joint Condition Prior to Overlay

Pavement performance data on ride and distress has been gathered routinely on the trunk highway (TH) system in Minnesota since 1976. Two important measures gathered are the surface rating (SR), which is a rating of visual distresses on a scale of 0.0 to 4.0 (a 4.0 represents a road with no visible distresses), and ride quality index (RQI), which is an indication of pavement roughness on a scale of 0.0 to 5.0, as described in Table 3.1. Figure 3.5 shows the average surface rating (SR) and ride quality index (RQI) recorded by the Mn/DOT Pavement Management Section for TH 53. Note that just prior to the concrete overlay, the RQI had deteriorated to a “fair” condition, and the SR had deteriorated to a level of 2.0, which is lower than the commonly accepted default threshold value of 2.5 or “fair condition”.

Table 3.1. RQI Categories and Ranges (5)

Numerical Rating	Verbal Rating
4.1 - 5.0	Very Good
3.1 - 4.0	Good
2.1 - 3.0	Fair
1.1 - 2.0	Poor
0.0 - 1.0	Very Poor

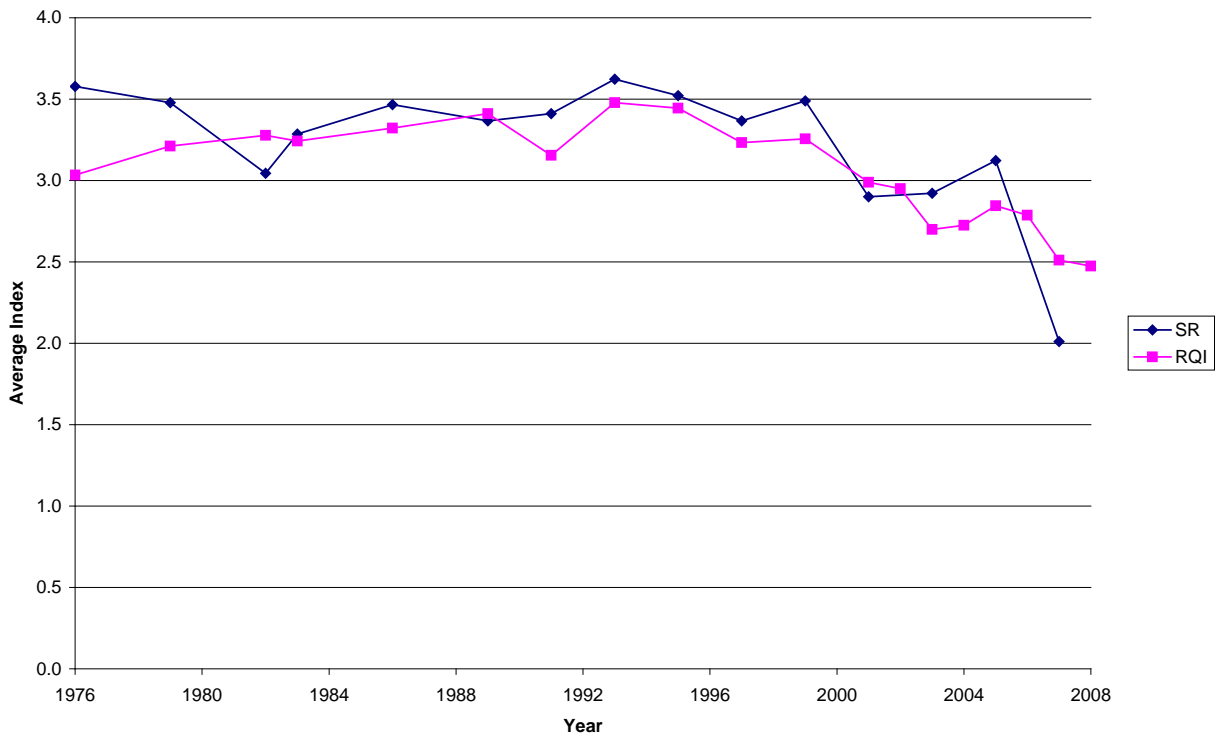

Figure 3.5. Average Pavement Condition Prior to Overlay

### TH 53 Overlay Description & Design

The final design for TH 53 was based on a 20 year projected traffic load of 3,546,000 ESALS. The thin unbonded overlay design chosen consists of a 5-inch thick concrete surface with a panel size of 12 ft by 12 ft. The larger (than typical for this slab thickness) panel size was chosen with the thought that if the joints deteriorate prematurely, the maintenance and repair quantities will be substantially less than if typical smaller panel sizes were used. In the interest of comparing the long term performance of large and small panel sizes, an approximately 1,000 to 1,500 ft. long section was constructed on the TH 53 project using 6-foot long by 6-foot wide panels. The unbonding and cushioning interlayer consists of a variable thickness (1 inch minimum) dense graded bituminous material, used for layer separation and surface cross-slope correction.

Figure 3.6 shows cross-section details of the unbonded overlay. Note that transverse joints in the overlay (12-foot spacing) may line up with the joints in the underlying pavement (27-foot spacing) at approximately 108-foot intervals, or every ninth joint, as no special effort was made to mismatch the joints. Most sources found in literature (3) recommended mismatching joints, however few have observed adverse performance when joints coincided. In the TH 53 project, there is also the difference in the skew of the joints between the overlay and original concrete slabs.

To keep costs low, the transverse contraction joints were not sealed, and edge drains were not retrofit along the shoulders. Centerline tie bars were used, but due to the 5-inch slab thickness, transverse joints were not doweled.

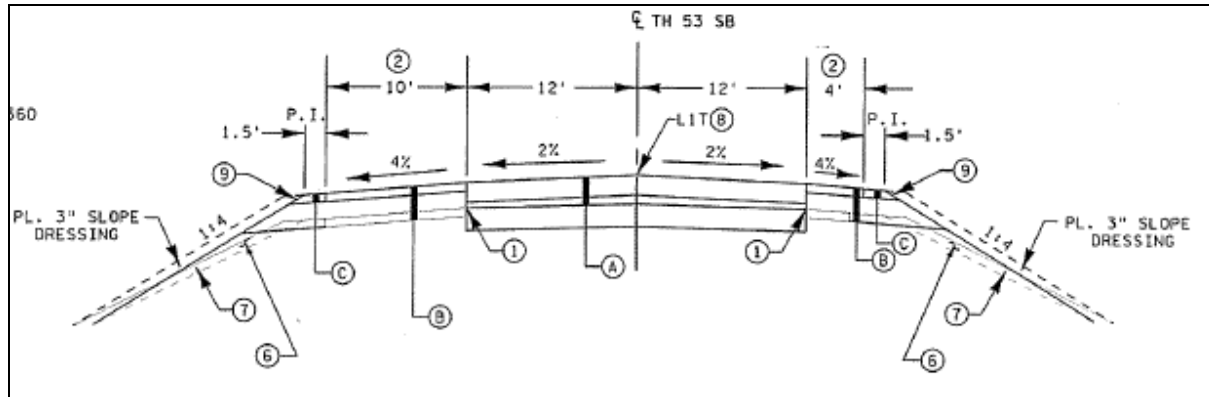

- (A) 5" CONCRETE PAVEMENT - SPEC. 2301  
VARIABLE DEPTH TYPE SP 12.5 NON-WEARING COURSE MIXTURE (SPNWB330B) - SPEC. 2360  
PLACE TACK COAT ON EXISTING CONCRETE SURFACE - SPEC. 2357 (INCIDENTAL)
- (B) 3" TYPE SP 12.5 WEARING COURSE MIXTURE (SPWEB330B) - SPEC 2360  
VARIABLE DEPTH AGGREGATE BASE (CY) CLASS 5 - SPEC. 2211
- (C) 3" AGGREGATE SHOULDERING (CY) CLASS 5 - SPEC. 2221
- (1) CHANGE OF CROSS SLOPE FROM INPLACE 0.01'/FT TO PROPOSED 0.02'/FT  
REQUIRES VARIABLE DEPTH BITUMINOUS PAVEMENT. 1" MINIMUM DEPTH  
MEASURED 12' LEFT AND RIGHT OF CENTERLINE.
- (2) FOR SHOULDER EXCEPTIONS, SEE TURN LANE LOCATIONS ON PLAN CONSTRUCTION  
SHEETS AND TYPICAL SECTION TS5.
- (3) 1" MINIMUM DEPTH AT CENTERLINE ON SUPERELEVATED ROADWAY.
- (4) 0.07'/FT MAXIMUM ROLL-OVER.
- (5) FOR BITUMINOUS PAVING TRANSITION AT STA. 861+30, SEE CONSTRUCTION DETAILS D11.
- (6) SELECT GRADING MATERIAL.
- (7) SALVAGE EXISTING TOPSOIL.
- (8) PROFILE GRADE TOP OF FINISHED SURFACE.
- (9) BIT. MATERIAL FOR SHOULDER TACK - SPEC. 2357 (2.0' WIDTH).

PL.  
DI

Figure 3.6. Cross-Section of TH 53 Overlay (9)

TH 53 was constructed using Mn/DOT's concrete pavement mix specifications for 2008 (6). The concrete mix was Mn/DOT type 3A21, which means it was air entrained, had strength grade A and cement-void ratio defined in Table 3.2, slump target of 2 inches (Table 3.3), a specified gradation of CA 50 and CA 15 inclusive (Table 3.4), a target air content of 7% and a water-to-cementitious materials ratio ( $w/c_m$ ) of 0.37.

Table 3.2. Concrete Grade Classification (6)

CONCRETE CLASSIFICATION				
Grade of Concrete	Type 1 Concrete		Type 3 Concrete	
	Cement-Void Ratio	Anticipated Compressive Strength Mpa (psi)	Cement-Void Ratio	Anticipated Compressive Strength Mpa (psi)
U	0.80	43 (6300)	0.70	39 (5600)
V	0.76	41 (6000)	0.66	37 (5300)
W	0.72	39 (5700)	0.62	34 (5000)
X	0.68	37 (5400)	0.58	32 (4700)
Y	0.62	34 (5000)	0.54	30 (4300)
A	0.56	31 (4500)	0.50	27 (3900)
B	0.52	28 (4100)	0.46	23 (3400)
C	0.44	22 (3200)	0.40	19 (2700)

Table 3.3. Concrete Slump Classification (6)

SLUMP RANGE DESIGNATION		
Slump Designation	Maximum Slump	Slump Range
1	25 mm (1 inch)	0-25 mm (0-1 inch)
2	50 mm (2 inches)	25-50 mm (1-2 inches)
3	75 mm (3 inches)	50-75 mm (2-3 inches)
4	100 mm (4 inches)	75-100 mm (3-4 inches)
5	125 mm (5 inches)	100-125 mm (4-5 inches)
6	150 mm (6 inches)	125-150 mm (5-6 inches)

Table 3.4. Concrete Mix Gradation Classification (7)

COARSE AGGREGATE DESIGNATION FOR CONCRETE									
Percent by mass (weight) passing square opening sieves (A)									
Aggregate Designation	50 mm (2 in.)	37.5 mm (1 ½ in.)	31.5 mm (1 ¼ in.)	25.0 mm (1 in.)	19.0 mm (¾ in.)	16.0 mm (5/8 in.)	12.5 mm (½ in.)	9.5 mm (¾ in.)	4.75 mm (# 4)
CA-00				100	95-100				0-10
CA-15	100	90-100			35-65			5-25	0-7
CA-25 or 2M6	100	95-100			50-80			20-40	0-7
CA-35 or 3M6		100	95-100		55-85			20-45	0-7
CA-45 or 4M6			100	95-100	65-95			25-55	0-7
CA-50				100	85-100			30-60	0-12
CA-60					100	85-100		40-70	0-12
CA-70						100	85-100	50-100	0-25
CA-80 (A)								100	55-95

The bituminous interlayer was type: SPNWB330B, denoted according to Mn/DOT's current 2360 Plant Mixed Asphalt specifications (8) The bituminous mixture was SuperPave or Gyratory design (denoted by *SP*), non-wear design (denoted by *NW*), and a maximum aggregate size of 19.0 mm, nominal maximum size of 12.5 mm, (denoted by *B*). The design was based on a 20 year design of 1 to < 3\*10<sup>6</sup> ESALS (denoted by 3), had a target air void content of 3.0%

(denoted by 30) and a binder Performance Grade (PG) of 58-28 (denoted by B). The aggregate gradation requirements are shown in Table 3.5.

Table 3.5. Bituminous Gradation Broadband Requirements (8)

<b>Aggregate Gradation Broad Bands</b> (% passing of total washed gradation)					
Sieve Size (mm [inch])	A or 4*	B or 3*	C or 2*	5*	E (SMA)
25.0 [1 inch]			100		See SMA Provisions
19.0 [3/4 inch]		100 <sup>(1)</sup>	85-100		
12.5 [1/2 inch]	100 <sup>(1)</sup>	85-100	45-90		
9.5 [3/8 inch]	85-100	35-90	-	100	
4.75 [#4]	25-90	30-80	30-75	65-95	
2.36 [#8]	20-70	25-65	25-60	45-80	
0.075 [#200]	2.0-7.0	2.0-7.0	2.0-7.0	2.0-7.0	

\*Marshall Designation

(1) The gradation broadband for the maximum aggregate size may be reduced to 97% passing for mixtures containing RAP, when the oversize material is suspected to come from the RAP source. The virgin material must remain 100% passing the maximum aggregate sieve size.

### Construction Sequence

The year prior to construction, there were several full depth culvert repairs which were backfilled with granular material and covered with bituminous. These areas were later reinforced with supplemental panel reinforcement during the overlay construction.

The PCC surface was swept clean (June 2008) and larger pieces of concrete were removed prior to interlayer placement. Potholes and other depressions were not repaired, but were filled in with the bituminous interlayer. Paving of the bituminous interlayer (August 2008) progressed at an approximate rate of 1.5 miles per day and took about 1.5 weeks to complete. When conditions warranted, the bituminous interlayer was whitewashed prior to paving of the PCC layer. Paving of the PCC layer (September 2008) progressed at an approximate rate of 1.5 miles per day and took about 1.5 weeks to complete. The quicker placement rate initially created challenges for the joint sawing crews; however this issue was believed to be corrected within the first day. Figure 3.7 shows the TH 53 thin unbonded concrete overlay prior to placement of the asphalt shoulders.



Figure 3.7. TH 53 Thin Unbonded Concrete Overlay, September 2008

### Material Sampling and Testing

In addition to the materials sampled for standard Mn/DOT quality assurance (QA) purposes, the Mn/DOT Office of Materials and Road Research collected material in the vicinity of the test cell to measure flexural strength (6\*6\*12 inches beams) and compressive strength (4-inch diameter cylinders). Test result from these samples are shown in Table 3.6 and Table 3.7, respectively.

Flexural strength beams were tested at 3, 7 and 28 days, indicating an average modulus of rupture of 400, 530 and 605 PSI respectively. The Mn/DOT standard on flexural strength pertains to pavements at least 6-inch thick, and is related to when traffic can be allowed on the pavement, allowing a maximum 7 day cure period. Compressive strength cylinders were tested at 3, 7 and 28 days, indicating average strengths of 2268, 3348 and 4212 PSI respectively. Mn/DOT specifies that the 28 day anticipated compressive strength of laboratory cured specimens should be at least 3900 PSI for class 'A' concrete.

Table 3.6. TH 53 Flexural Beam Strength Test Results

Beam NO.	Station	Date Made	Mix NO.	Test Date	Ave. Width "B"	Ave. Depth "D"	Total Test Load (psi)	Area Correction (%)	Modulus Rupture (psi)	Age
MI08-0073 TH 53 B#1	Not Available	09/10/08	5" Unbonded Overlay	2:45 pm 9/13/08	6.10	5.95	380	0 %	380	3 Day
MI08-0074 TH 53 B#2	Not Available	09/10/08	"	2:55 pm 9/13/08	6.10	5.95	415	0 %	415	3 Day
MI08-0075 TH 53 B#3	Not Available	09/10/08	"	3:10 pm 9/13/08	6.10	5.90	400	+ 1.7 %	405	3 Day
MI08-0076 TH 53 B#4	Not Available	09/10/08	"	3:00 pm 9/17/08	6.15	5.95	515	- 0.98 %	510	7 Day
MI08-0077 TH 53 B#5	Not Available	09/10/08	"	3:20 pm 9/17/08	6.05	6.00	540	- 0.98 %	530	7 Day
MI08-0078 TH 53 B#6	Not Available	09/10/08	"	3:10 pm 9/17/08	6.35	5.95	565	- 3.5 %	545	7 Day
MI08-0079 TH 53 B#7	Not Available	09/10/08	"	3:00 pm 10/8/08	6.05	5.95	585	+ 0.9 %	590	28 Day
MI08-0080 TH 53 B#8	Not Available	09/10/08	"	3:10 pm 10/8/08	5.95	5.90	570	+ 4.2 %	595	28 Day
MI08-0081 TH 53 B#9	Not Available	09/10/08	"	3:20 pm 10/8/08	6.00	5.95	620	+ 1.6 %	630	28 Day



## Chapter 4. Pavement Structural Testing and Analysis

This chapter describes the research testing aimed at characterizing the pavement's structural response both with falling weight deflectometer (FWD) and dynamic load testing.

### Falling Weight Deflectometer (FWD)

Understanding the change in deflections with the application of a thin unbonded concrete overlay is one of the objectives of this study. Continued FWD testing will be used toward that effort. The preconstruction data from September 3, 2008 and the post construction data from April 10 and August 21, 2009 were analyzed. The preconstruction measurements were taken on September 3, 2008; eight measurements at station 728+00 (4,400 feet west of St. Louis County Road 885/7) and four measurements at station 679+50 (450 feet east of St. Louis County Road 885/7). In addition, there were measurements across 16 joints and one crack beginning at RP 18 in the driving (right) lane of southbound TH 53. Post construction testing occurred in and around the test cell as shown in Figure 4.1. Note that an additional two joints on either side of the 2-panel test section were tested for a total of seven joints.

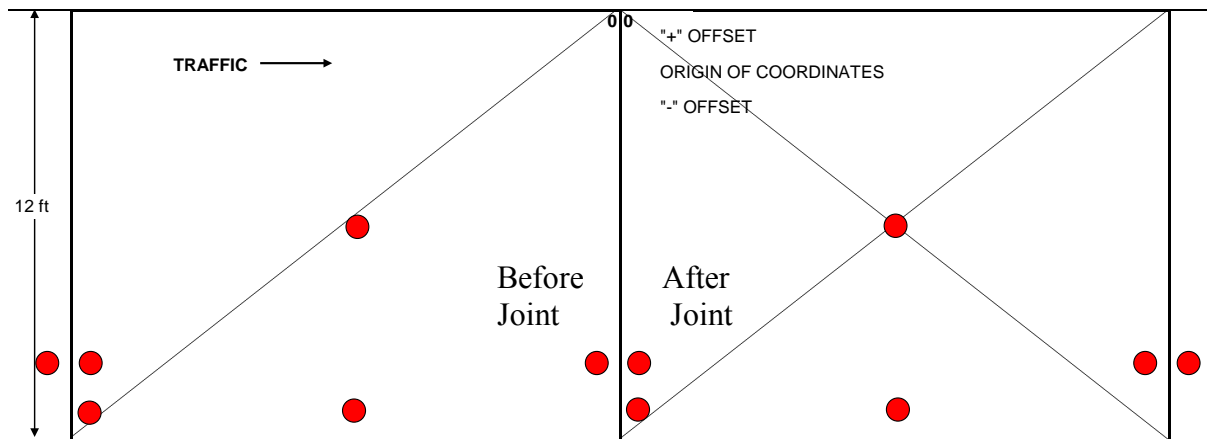

Figure 4.1. Routine FWD Testing Locations in Test Cell 53-1

The analysis included a review of the deflection results, and backcalculation. The preconstruction data showed the pavement section to be stiffer than expected and also showed the joint load transfer to be low. The post construction data also showed the pavement section as stiff as or stiffer than expected and very low differential deflection across the joints. Overall, the post construction deflection results show very good structural capacity.

Most of the analysis effort was with the August 21, 2009 data. There was limited preconstruction data because several of the tentative sites for installing the instrumentation were not available for testing due to construction activity. The April 10, 2009 deflection testing was during the spring thaw and the subgrade was still frozen.

A SLIC check was done on the mid-panel test to check for sensor function and positioning as shown in Figure 4.2. The SLIC analysis was applied to the average SLIC transformed values for all of the mid-panel deflection basins (SLIC cannot be reliably used on individual basins.) SLIC results did not find any concerns with the FWD function. It did, however, show some unique characteristics of the pavement being tested. The concave up shape of the SLIC plot indicates a very shallow deflection basin. Most highway pavements are either



linear or concave down. Also, there is a slight jog in the plot line between the third and fourth SLIC plot point indicating a slight discontinuity in the deflection basin. This discontinuity also shows up between the same sensors when comparing the measured and backcalculated deflection basins. The source of this slight discontinuity cannot be determined until SLIC results of deflections by this FWD using the same setup is evaluated. If it remains over several different pavement types, it is from the machine, but if not, it is a pavement response characteristic. The unbound concrete section (very stiff over thin soft over very stiff) might be the source.

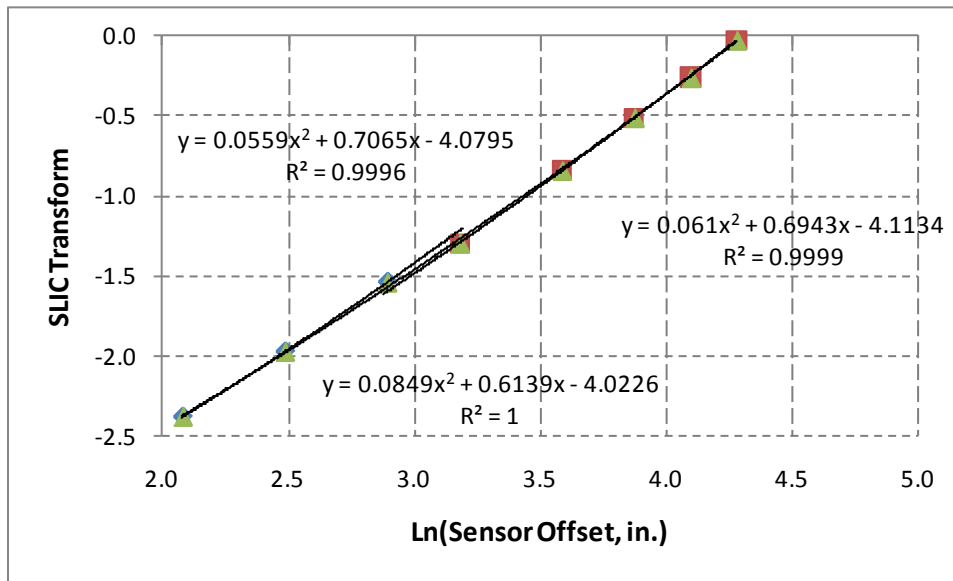

Figure 4.2. SLIC Check of Mid-Panel Deflection Data

The pavement layer moduli was estimated using Evercalc<sup>®</sup> Pavement Backcalculation Program, Version 5.20 – March 2001 from the Washington State Department of Transportation. Backcalculation is a process of using a linear elastic model to calculate a deflection basin. This basin is compared to the measured basin and the layer moduli are adjusted iteratively to minimize the difference between the calculated and measured deflection basins. All of the mid panel test results (including individual FWD drop results) at the instrumentation site were analyzed. The pavement model used is shown in the column headings for each of the layers used in Table 4.1. The moduli values for all layers are considered to reasonably represent the materials. The new concrete layer is the stiffest at 7,000,000 psi followed by the old concrete at 4,600,000 psi. The bituminous separation layer was estimated to be 2 inches thick (actual thickness varies) and the moduli values are consistent with bituminous materials. For this unbonded pavement, the bituminous stiffness has minimal influence on the overall deflections measured by the FWD. The 150-inch layer under the original concrete includes the 6-inch aggregate base, any subgrade preparation, and native soils to that depth. The bottom layer is used similar to a ‘hard bottom’ but rather than fixing the modulus of this layer, Evercalc was allowed to calculate a stiffness. Allowing Evercalc calculate a stiffness for the bottom layer helps minimize the sensor fit errors at the sensors furthest from the load plate; this is particularly useful when deflections are low. A tenth of a mil (2.5 microns) difference between the measured and calculated deflection at the outer sensor could be 20 or more percent different than the measured deflection and could force the backcalculation routine to minimize this difference by

changing intermediate layer moduli to compensate, often resulting in moduli values that are not consistent with the material being modeled.

Table 4.1. Backcalculated Layer Moduli

	Calculated Moduli, ksi.				
	5" PCC	2" Bit	8" PCC	150" unbound	Half-space
Average	7,082	736	4,607	24.0	1,035
Median	7,293	1,000	4,166	23.1	699
Std. Dev.	1,992	371	1,837	5.5	907
C.O.V.	28%	50%	40%	23%	88%

Figure 4.3 is a plot comparing the average measured and average calculated deflection basin (there are two deflection basin plots in Figure 4.3). The third wavy plot on the right side corresponds with the right secondary vertical axis and is the average percentage difference between the measured and calculated deflections, by sensor. This indicates that the average calculated deflections under the load plate are slightly higher than measured, slightly lower through the 24 to 60-inch offset, and again slightly higher at the 72-inch sensor. This high-low-high pattern, if strong enough could be an indication that the model (layering or thicknesses) might need to be adjusted. In this case, however, the absolute magnitude of the differences are so low that they are all less than the precision capability of the FWD (about plus or minus 0.9 percent plus or minus 2 microns). It would make no sense to adjust the model to try to improve on the fit because there are likely many small adjustments that could be made that would result in improvement, but no rational way of identifying the one that is most representative of the pavement tested.

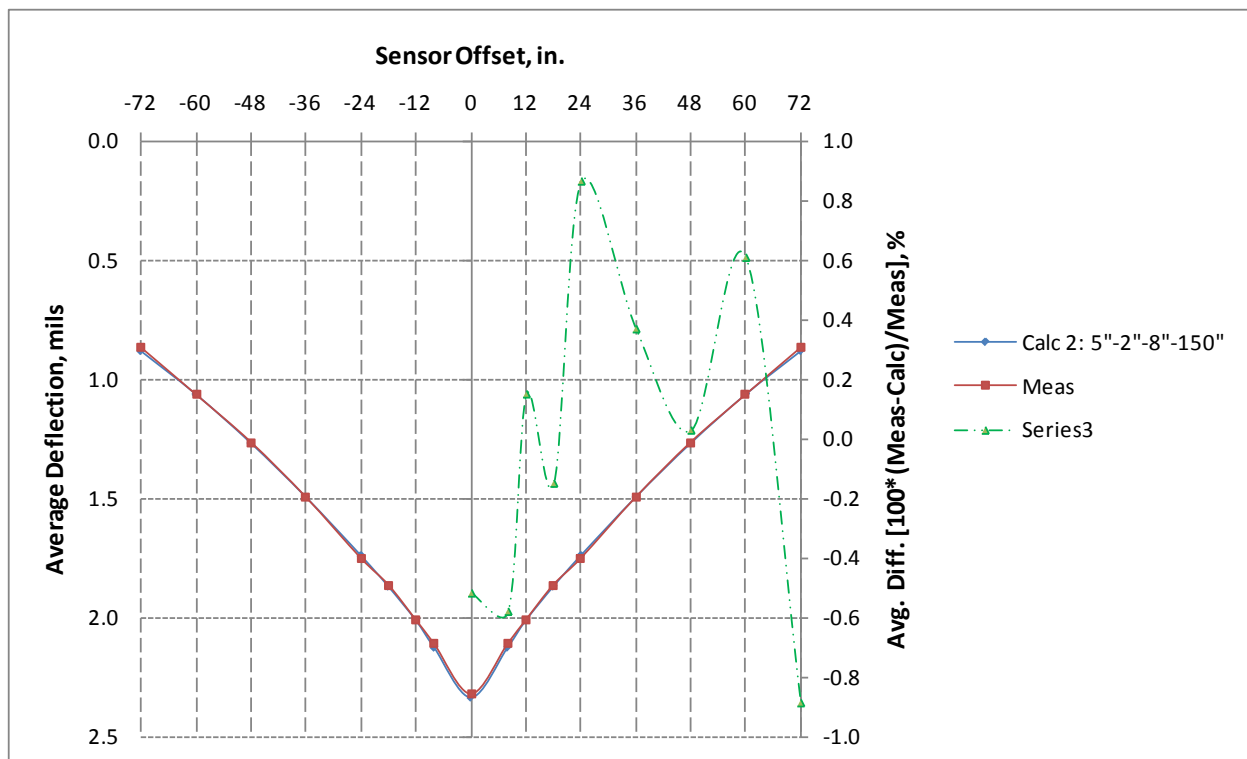

Figure 4.3. Comparison of EverCalc Calculated Deflections and the Measured Deflection

The FWD tests at the joints were evaluated also analyzed to characterize how well the pavement is able to transfer the load across the joint. The top concrete layer is a 5-inch thick and there are no load transfer devices (no dowels). This 5-inch concrete is on the old 8-inch concrete pavement with a thin bituminous interlayer that is meant to prevent the two concrete layers from bonding. The joints in the new overlay were sawed at 12-foot spacing with no effort to coordinate their location with the joints or cracks in the underlying concrete. Therefore, most of the joints will be resting on a rigid concrete slab, which limits the vertical deflection at the joints. Figure 4.4 and Figure 4.5 show the average deflection basins for the test positions before and after the joint. The FWD was configured with one sensor at about 12 inches behind the load plate to allow deflections to be measured on both the loaded side and the unloaded side of the joint when the load plate is positioned either immediately before or immediately after the joint.

The traditional method used to evaluate the load transfer efficiency of the joint is to use the deflection sensor that is about the same distance away from the joint on the unloaded side as distance the sensor at the center of the load plate is from the joint. With the FWD configuration used August 21, 2009, the sensor 12 inches in front of the load plate is divided by the deflection under the load plate when the plate is before the joint. When the plate is in front of the joint, the deflection 12 inches behind the load plate is divided by the deflection under the load plate. The results are expressed as a percentage. Typical values for new conventional doweled concrete pavements are in the low to mid 90 percent range. The average load transfer efficiency (LTE) for this pavement at the time of test is 84 percent. The average difference in deflection across the joint however is very low at 0.56 mils. The difference in the intercepts of the surface deflection plots shown in Figure 4.4 is 0.76 mils. This can be inferred to be representative of the actual differential slab movement at the joint during a transient 9,000 lb impulse load.

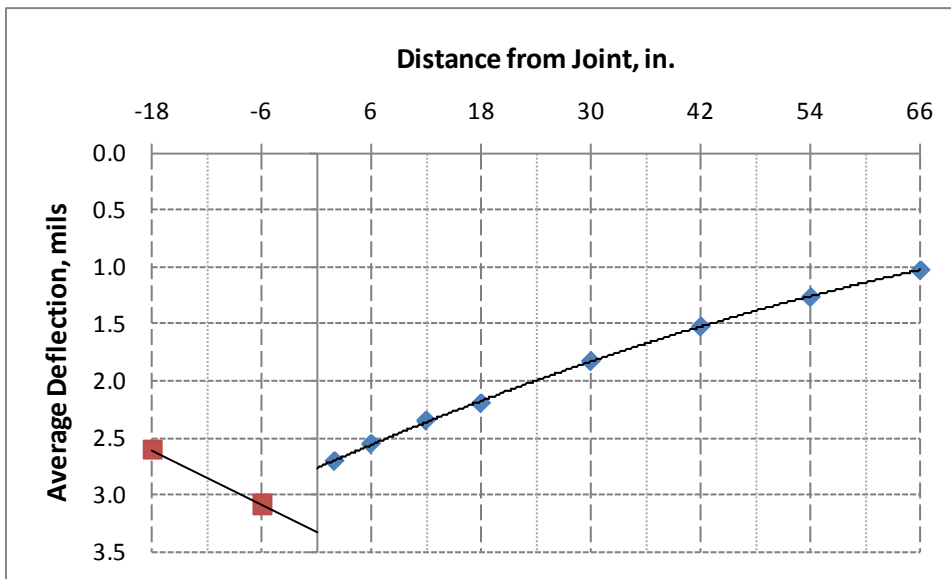

Figure 4.4. Average Deflection Basin when the Load Plate is Before the Joint

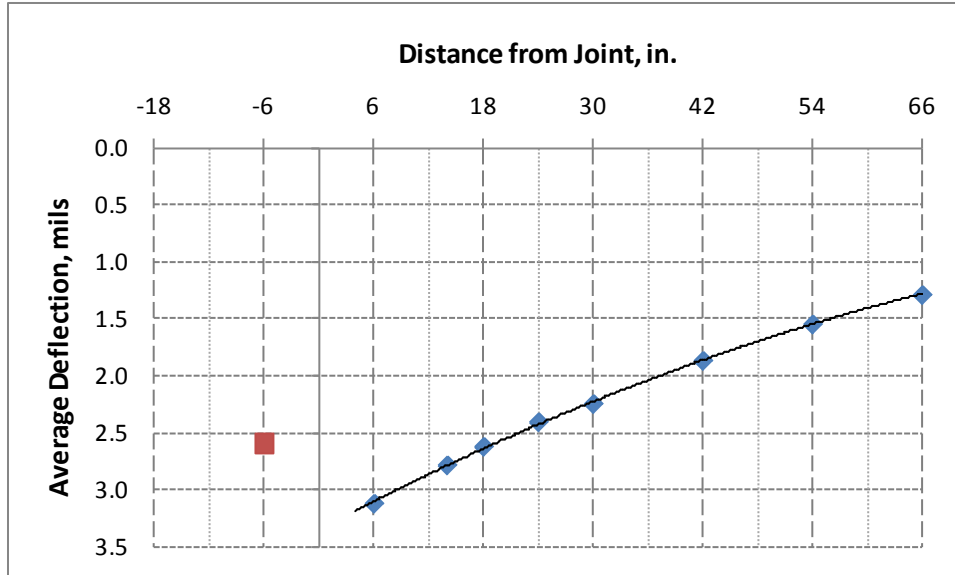

Figure 4.5. Average Deflection Basin when the Load Plate is After the Joint

The mid-panel deflections tend to be lower than the deflections at the edges of the slab. The two plots in Figure 4.6 show the deflections increase as the load moves from the center of the slab toward the edge. The ‘Inner Basin’ plot comparison is for the sensors 0 to 24 inches from the center of the load and the ‘Outer Basin’ plot compares the deflections from the sensors 36 to 72 inches from the center of the slab. Both the inner and outer part of the basin increase about the same amount with the inner part increasing slightly more than the outer part. This infers that much of the increase is due to the combined effect of being closer to the edge and less support under the edge of the slab.

The critical loading locations for conventional concrete pavements are at the corners and edges. This unbonded pavements also had the highest deflections at the corners and edges, but the deflections are lower. The average corner deflections under the load plate are about 2.75 times greater than that measured at the center of the slabs. There were a couple center lane joint tests and the deflections there were similar to that measured at the center of the slab. The deflection difference between the center of the load plate was actually smaller than measured mid-slab, possibly due to higher slab temperatures at the surface during mid-day August testing.

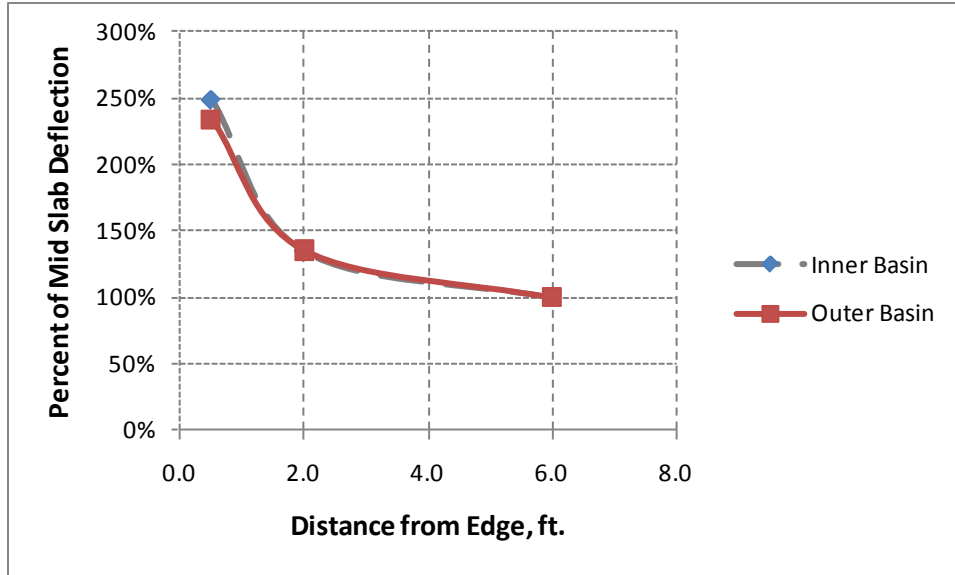

Figure 4.6. Comparison of the Deflections by Distance from Center of Slab

Table 4.2 shows the average deflections measured before overlay construction on culvert areas patched with hot mixed asphalt (HMA). The deflections were measured under the 300 mm diameter load plate, and thus represent the maximum deflections. The measurements were taken on September 3, 2008. Three HMA culvert patch areas were tested in the outer wheel path of the driving (right) lane. The first area tested was a patch over an 18-inch diameter corrugated metal pipe (CMP) located at 778 + 98.91 (approximately 1,300 feet west of St. Louis County Rd 94). Four FWD drops were made at each of the following stations 779+30, 779+00 and 778+70. The second test area was a HMA patch over a 24-inch diameter CMP located at 656+08.16 (approximately 2,855 feet east of St. Louis County Rd 7/885). Four drops were made at station 656+00. The third test area was a HMA patch over a 44-inch diameter reinforced concrete pipe (RCP) located at station 782+57.66 (approximately 1,260 feet west of St. Louis County Rd 94). Four drops were made at each of the following stations: 782+80, 782+50 and 782+20. The loads are averaged across all drops at each location.

Table 4.2. TH 53 Average Deflections at a Given Load and Location (Prior to Overlay)

Deflection (mils)	Culvert	Station	Average Load (lbs)			
			6,825	9,716	11,687	14,675
18" CMP @ 778+98.91		779+30	7.94	11.15	14.11	16.86
		779+00	8.49	11.74	15.05	17.51
		778+70	9.03	11.34	14.09	17.67
24" CMP @ (656+8.16)		656+00	9.58	13.87	17.87	21.57
44" RCP @ 782+57.66		782+80	6.56	9.48	12.19	14.69
		782+50	8.15	11.30	14.58	17.03
		782+20	6.73	9.46	12.58	14.49

**Structural Testing Conclusions**

FWD and structural testing should be repeated at the same locations over the coming years to identify if structural changes occur. One possible source of change is gradual profile change of the underlying pavement due to small vertical movements caused by such things as frost heave, moisture changes, and/or long term consolidation of the unbound material and bituminous interlayer.

## Chapter 5. Pavement Surface Testing and Evaluation

This chapter describes the research testing that was undertaken after construction of the TUBOL in cell 53-1 (TH 53). One of the research objectives for the cell was the characterization of the early age performance of the pavement.

### Ride Quality Measurements

Ride quality of the TH 53 overlay is periodically measured using both a light-weight inertial surface analyzer (LISA) and a Mn/DOT pavement management van, as shown in Figure 5.1. Table 5.1 presents the 2009 ride quality results from the LISA and the pavement management van. Note that testing with the LISA took place in the spring and late summer of 2009, in accordance with the routine monitoring plan. The LISA took measurements in both the left and right wheel paths of the driving lane, but only in the 1,000-foot vicinity of the test cell. Testing with the pavement management van was conducted for the entire project length on 2009. All ride results are reported in units of inches per mile (in/mi). The ride quality testing results categorize the TH 53 overlay as a very smooth pavement, certainly a dramatic improvement over previous conditions.



Figure 5.1. LISA [Left] and Pavement Management Van [Right]

Table 5.1. Ride Results for: LISA [Left] and Pavement Management [Right] - 2009

Date	Path	IRI	RP	IRI	Notes
Apr-09	LWP	54.5	12 to 13	64.6	
	RWP	54.4	13 to 14	56.5	Test Cell
Aug-09	LWP	40.7	14 to 15	56	
	RWP	44.9	15 to 16	51.8	
			16 to 17	78.2	Bridge No. 69061
			17 to 18	59.1	
			18 to 19	55.1	
			19 to 20	56.8	
			20 to 21	60.1	
			Average	60	
			Minimum	52	
			Maximum	78	

## Distress Surveys

In spring 2009, a detailed visual distress survey was carried out (over the entire 9+ project length) to ascertain both the number and condition of distresses present in the overlay after the first winter. The survey found that approximately 40 cracks had formed in the overlay, with severity ratings of: 7% high, 41% medium, and 51% low. Figure 5.2 shows a qualitative depiction of the different severity levels.

Figure 5.3 to Figure 5.7 show the locations of surface distresses observed during the second distress survey, conducted in August 2009. The distresses were visually rated for severity (Figure 5.2). Note that 3, 2 and 1 denote high, medium and low severity cracking, respectively. Each crack was assigned an I.D. number that can be used to reference a picture of the distress in Appendix A. These figures also show locations of the full depth (8-inch thick) concrete pavement sections constructed on TH 53, and the approximate locations of the supplemental panel reinforcement installed over excessively cracked portions of the original concrete pavement. Note that the fall survey was only conducted on half of the project length, due to restrictions that arose from construction of a similar TUBOL on the adjacent northbound lanes of TH 53.



Figure 5.2. From Left to Right: High (3), Medium (2) and Low (1) Severity Cracking

Based on the random occurrence of the transverse cracks through the panels, it is deduced they were likely caused by late sawing of the joints. It seems that paving the thin concrete overlay progressed much faster than the capabilities of the sawing equipment on site. The higher surface to thickness ratio of the overlay also presented additional challenges in timing the saw cuts. The skewed nature of some of the cracks (Figure 4.3, rightmost photo) leads one to believe they are more reflective in nature. In addition to transverse cracking through the panels, the fall 2009 survey also revealed the presence of other distresses, notably joint spalling, which was again most likely caused by improper timing (early) of the joint sawing. It should be noted that no mid panel cracks have appeared in the overlay section with 6-foot by 6-foot panels.



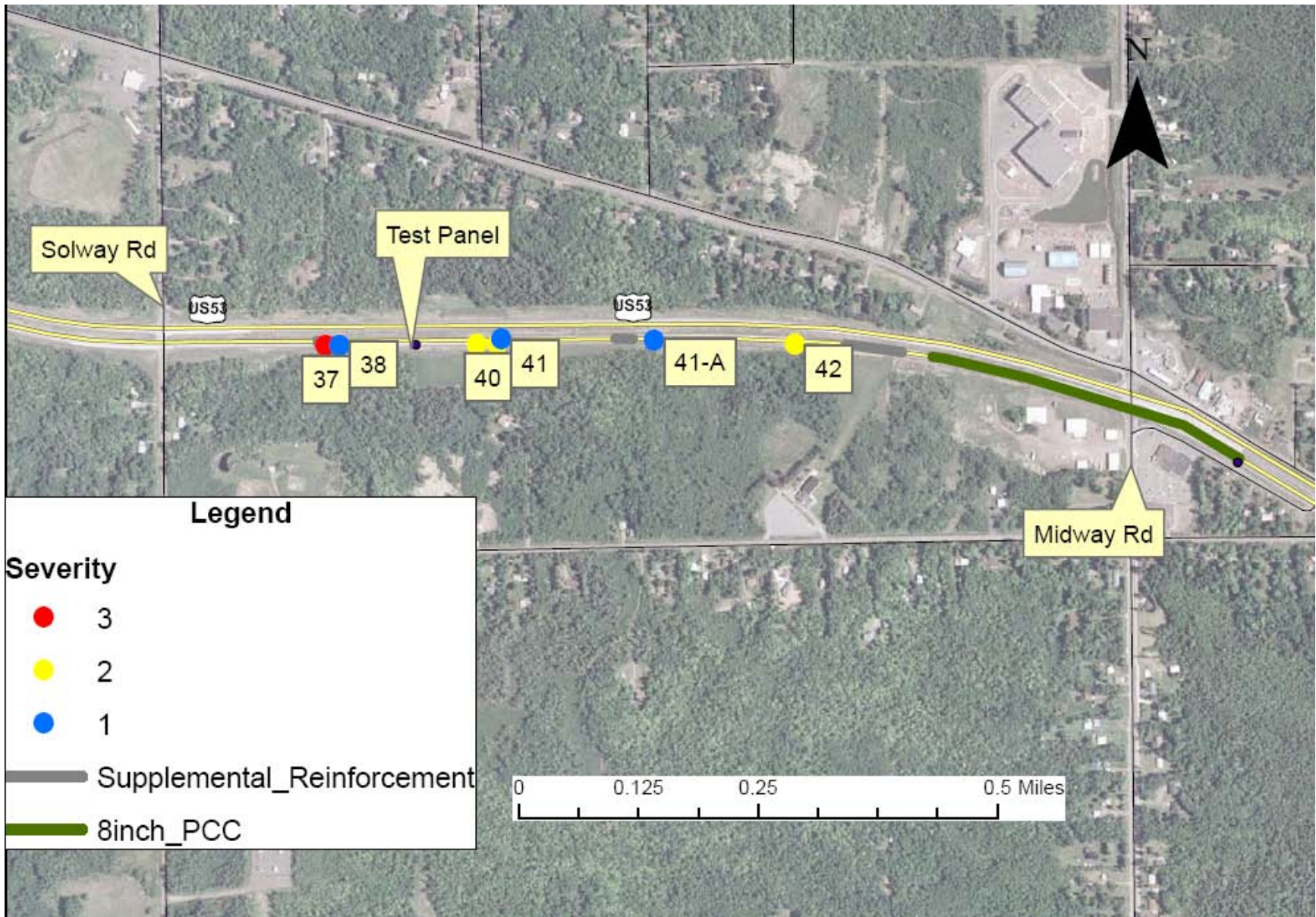

Figure 5.3. TH 53 Distress Map [Midway Rd to Solway Rd], April 2009 (Farm Service Agency, 2002)

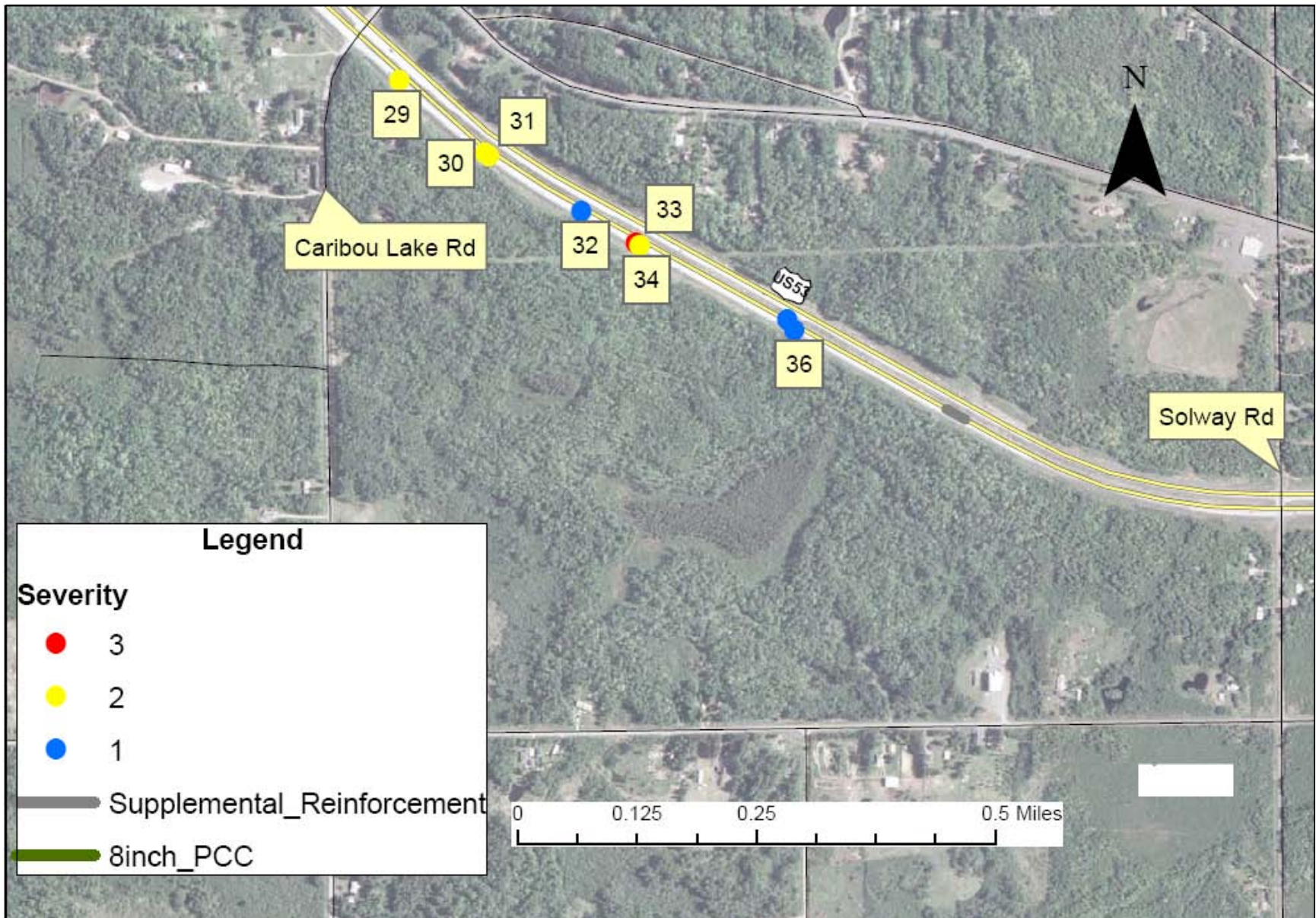

Figure 5.4. TH 53 Distress Map [Solway Rd to Caribou Lake Rd], April 2009 (Farm Service Agency, 2002)

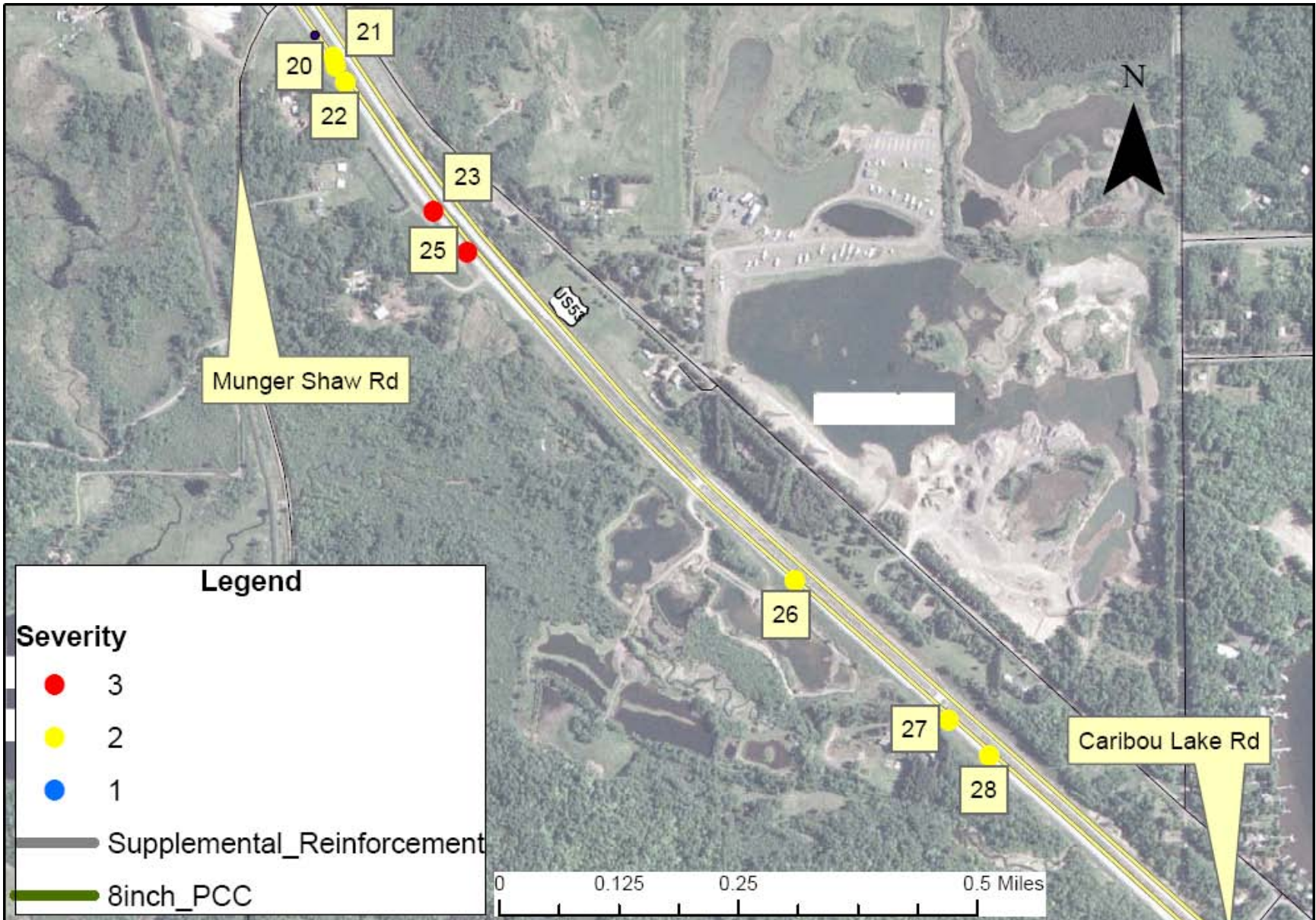

Figure 5.5. TH 53 Distress Map [Caribou Lake Rd to Munger Shaw Rd], April 2009 (Farm Service Agency, 2002)

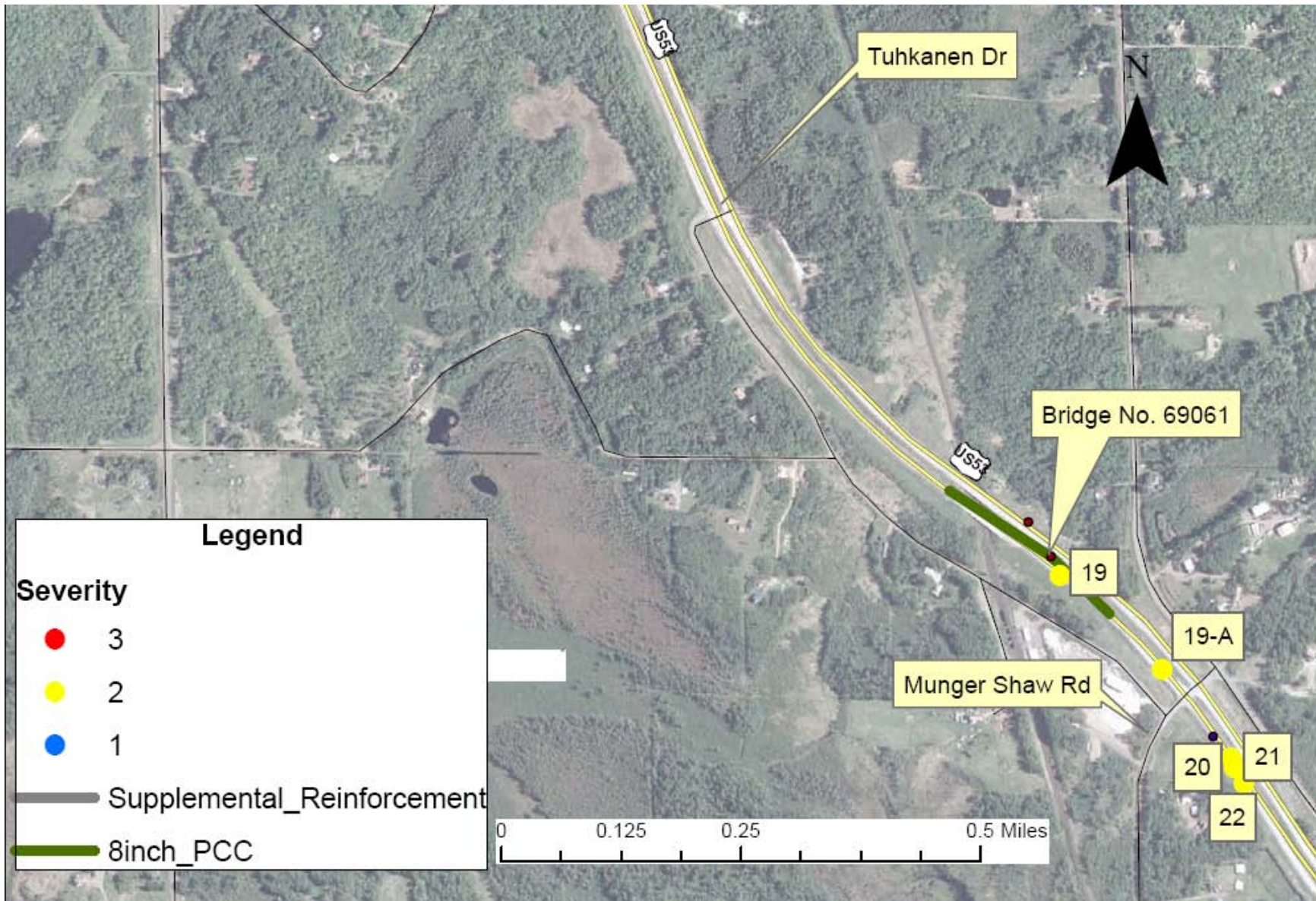

Figure 5.6. TH 53 Distress Map [Munger Shaw Rd to Tuhkanen Dr.], April 2009 (Farm Service Agency, 2002)



Figure 5.7. TH 53 Distress Map [Tuhkanen Dr. to Industrial Rd], April 2009 (Farm Service Agency, 2002)

## Chapter 6. Conclusions

In the summer of 2008, TH 53 near Duluth, MN, was rehabilitated with a thin unbonded concrete overlay. The Minnesota Department of Transportation (Mn/DOT) decided to study a small section of the overlay as part of a state funded research project that included a several thin unbonded concrete overlays at the Minnesota Road Research (MnROAD) facility. The TH 53 overlay is significantly thinner than conventional unbonded concrete overlays, with a 5 inch thick concrete surface. Panel size was 12 feet long by 12 feet wide, with the exception a short trial section with smaller 6 feet long by 6 feet wide panels. Although heavily loaded by trucks, the overlay undoweled transverse joints, relying on the underlying concrete pavement for support.

Electronic sensors designed to measure environmental and load responses were installed concurrently with construction. The load response sensors indicate that microstrain induced through vehicle loading is relatively small. Data from the sensors will be used to model thin unbonded concrete overlay behavior. Falling weight deflectometer (FWD) testing has, and will continue to be conducted throughout the study. Initial test results indicate that the pavement is providing more than adequate structural capacity. Testing prior to and following construction of the overlay revealed an increase in average joint load transfer efficiency. Several visual distress surveys have documented approximately 40 transverse cracks that have formed in the 9+ mile overlay. These cracks had severity ratings in August 2009 of: 7% high, 41% medium, and 51% low. Due to the thinner surface layer, the paving process progressed rapidly, and the high surface to thickness ratio increased the challenge of predicting joint formation times.

Performance of the TH 53 test section will continue to be monitored and compared to the MnROAD test sections. The data from both projects will be used toward the development of improved distress and life prediction models. These models will ultimately be used in the development of mechanistic-empirical design methods for thin unbonded concrete overlays.

### Recommendations

It is recommended to conduct a thorough evaluation/review of the northbound side of TH 53, as this pavement was in a similar condition and received a similar overlay treatment in 2009.

It is also recommended to construct a short test section where the joints are not cut, but allowed to crack naturally. This would help to provide insight into optimal joint spacing and the associated overlay performance.

FWD testing should be repeated at the same locations over the coming years to identify if structural changes occur. One possible source of change is gradual profile change of the underlying pavement due to small vertical movements caused by such things as frost heave, moisture changes, and/or long-term consolidation of the unbound material and bituminous interlayer.

## References

1. Clyne, T. *Construction Plan for Reconstruction of MnROAD Mainline and Low Volume Road*. State Project No. 8680-157. Unpublished Project Design Plans, Minnesota Department of Transportation, St. Paul, MN, December 2007.
2. Burnham, T., Watson, M. *Thin Unbonded PCC Overlay of PCC Pavements on High Volume Roads*. Task 2 Report: Test Cell Design, Materials Sampling, and Pavement Performance Monitoring Plans, Unpublished, July 2008.
3. ERES Consultants. *Evaluation of Unbonded Portland Cement Concrete Overlays*. Transportation Research Board, National Research Council, NCHRP Report No. 415, Washington, D.C., 1999.
4. Watson, M., Burnham, T. *Thin Unbonded PCC overlay of PCC Pavements on High Volume Roads*. Task 1 Report: Literature Review, Unpublished, June 2008.
5. Janisch, D. *An Overview of Mn/DOT's Pavement Condition Rating Procedures and Indices*. Minnesota Department of Transportation, St. Paul, MN, May 2006.
6. Minnesota Department of Transportation. *Standard Specifications for Construction, Standard Specification No. 2461: Structural Concrete*. Minnesota Department of Transportation, St. Paul, MN, 2005.
7. Minnesota Department of Transportation. *Standard Specifications for Construction, Standard Specification No. 3137: Coarse Aggregate for Portland Cement Concrete*. Minnesota Department of Transportation, St. Paul, MN, 2005.
8. Minnesota Department of Transportation. *Standard Specifications for Construction, Standard Specification No. 2360: Plant Mixed Asphalt Pavement*. Minnesota Department of Transportation, St. Paul, MN, 2005.
9. Minnesota Department of Transportation. *Construction Plan for: Misc. Grading, Gravel Base, Concrete Pavement, Bituminous Shoulder and Signals*. State Project No. 6916-59 (Fed. Proj. No. F011-3(51)). Unpublished Project Design Plans, Minnesota Department of Transportation, St. Paul, MN, 1970.

## **Appendix A. Documentation of Early Distresses**





Figure A.1. Distress No. 1 [Left] & No. 2 [Right], April 2009

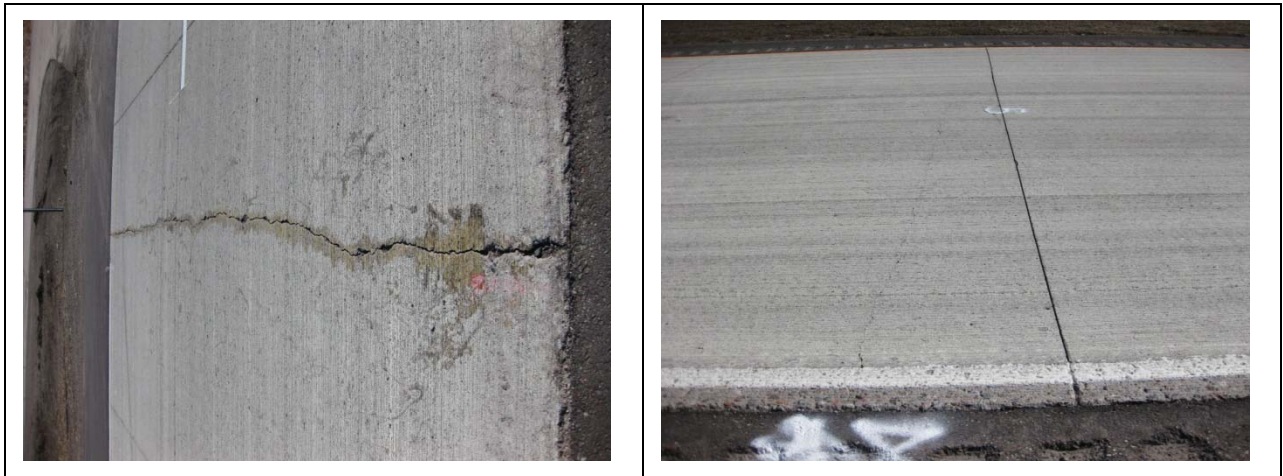

Figure A.2. Distress No. 3 [Left] & No. 4 [Right], April 2009

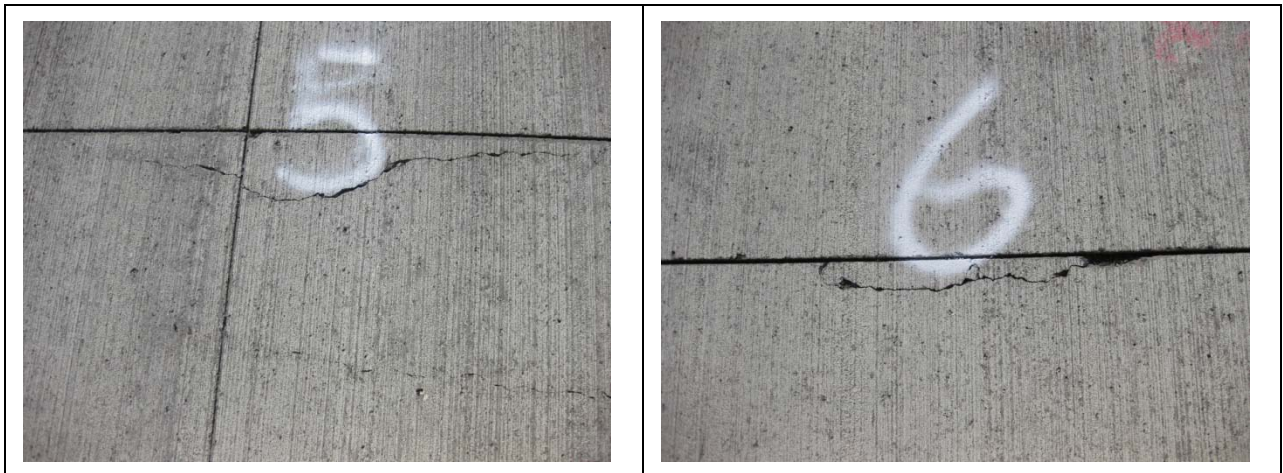

Figure A.3. Distress No. 5 [Left] & No. 6 [Right], April 2009

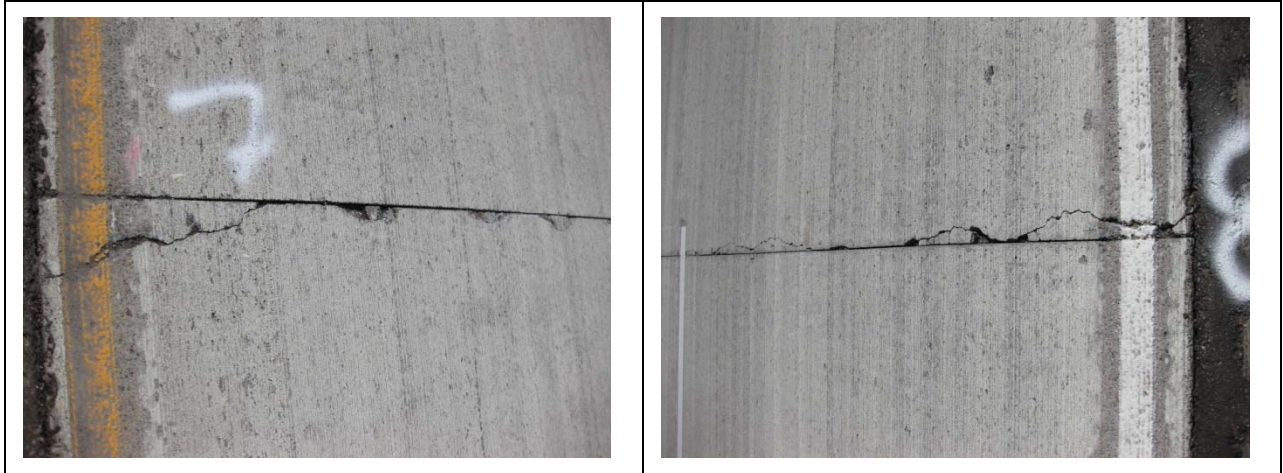

Figure A.4. Distress No. 7 [Left] & No. 8 [Right], April 2009

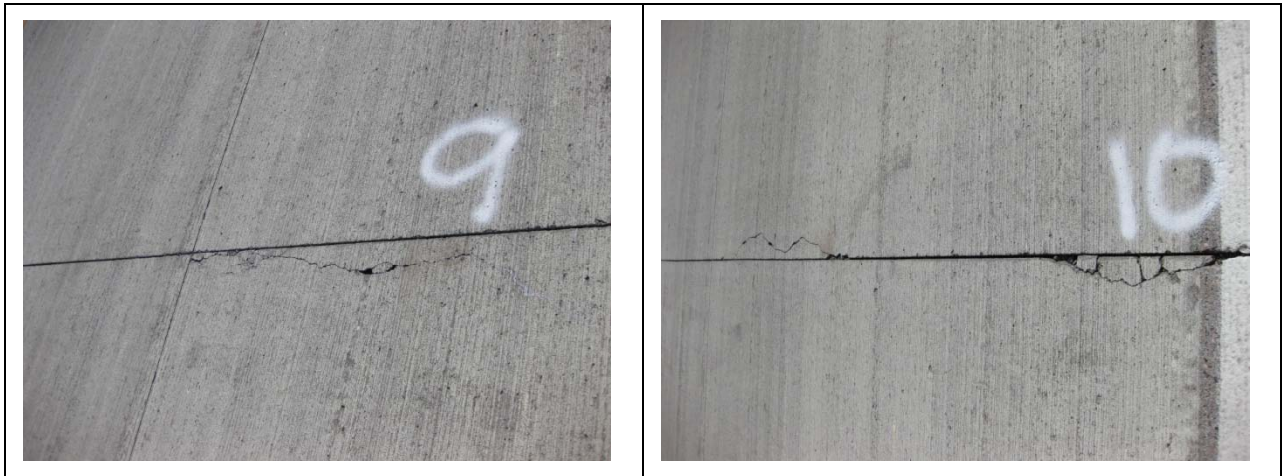

Figure A.5. Distress Nos. 9 & 10, April 2009

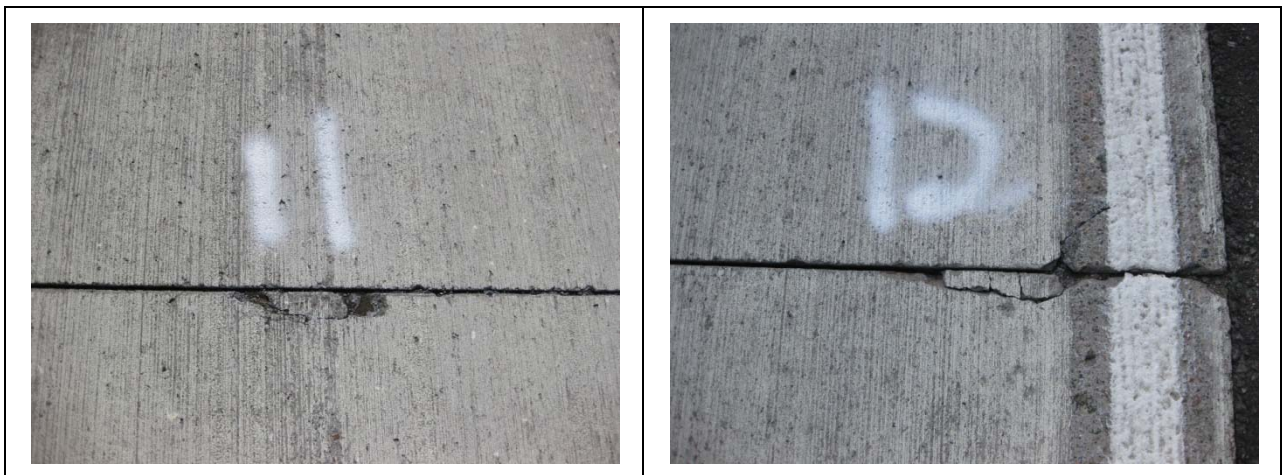

Figure A.6. Distress No. 11 [Left] & No. 12 [Right], April 2009

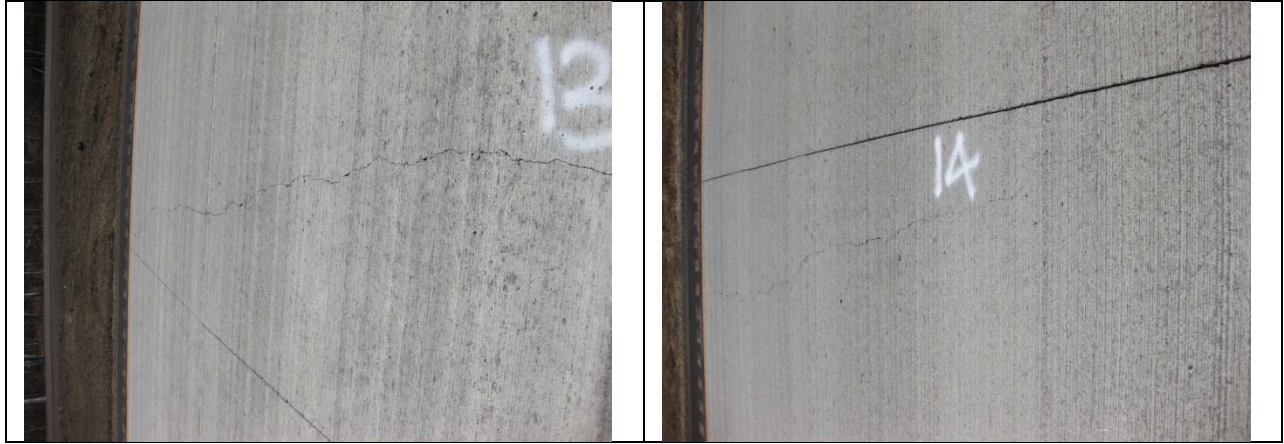

Figure A.7. Distress No. 13 [Left] & No. 14 [Right], April 2009

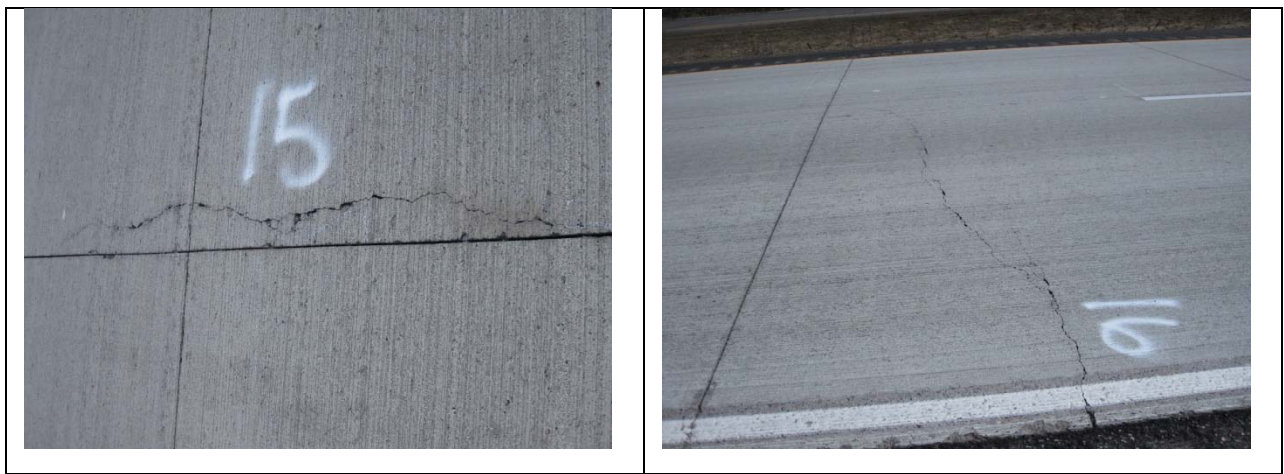

Figure A.8. Distress No. 15 [Left] & No. 16 [Right], April 2009

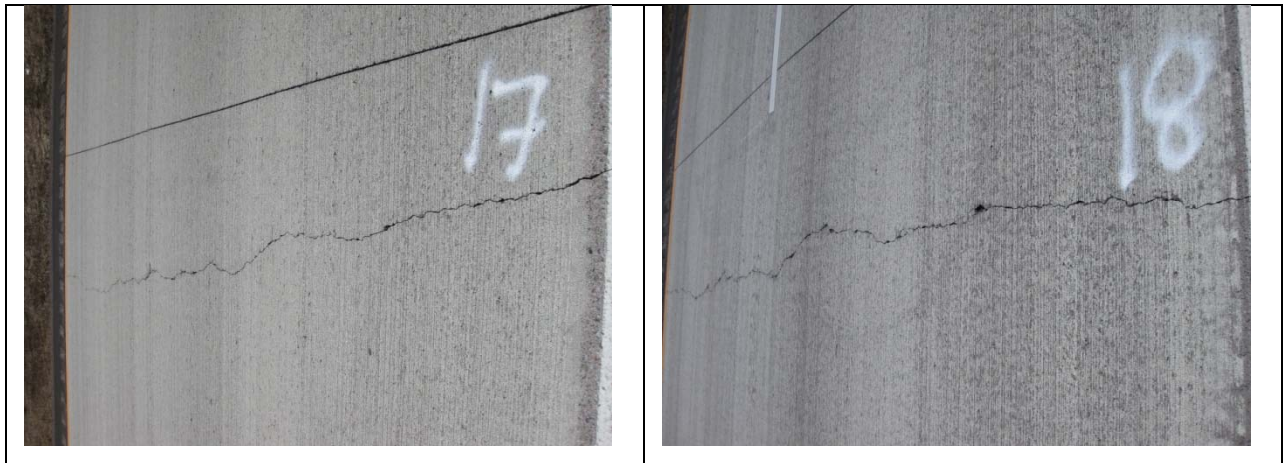

Figure A.9. Distress No. 17 [Left] & No. 18 [Right], April 2009



Figure A.10. Distress No. 19 [Left] & No. 20 [Right], April 2009

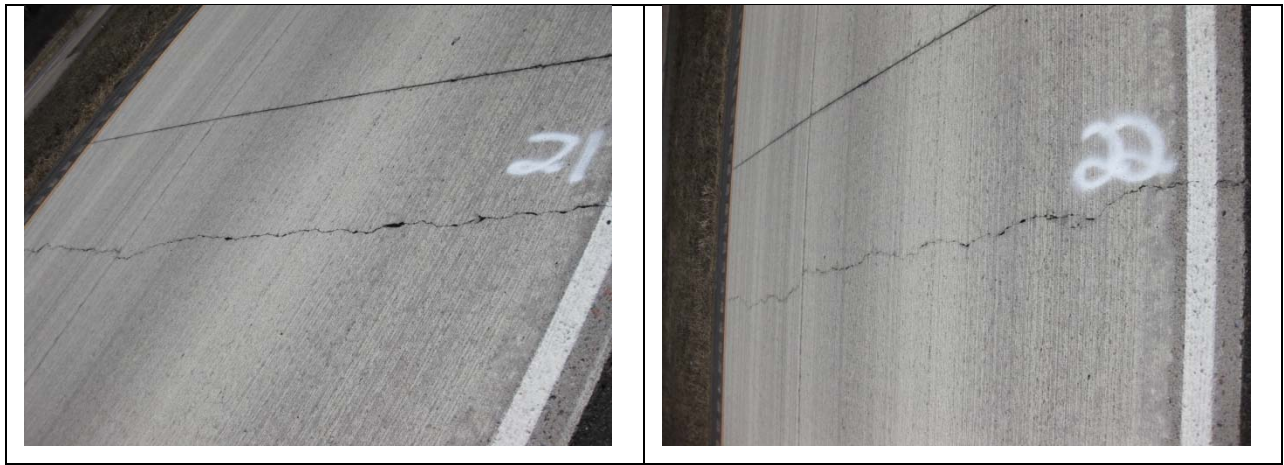

Figure A.11. Distress No. 21 [Left] & 22 [Right], April 2009



Figure A.12. Distress No. 23 [Left] & No. 24 [Right], April 2009



Figure A.13. Distress No. 25 [Left] & No. 26 [Right], April 2009

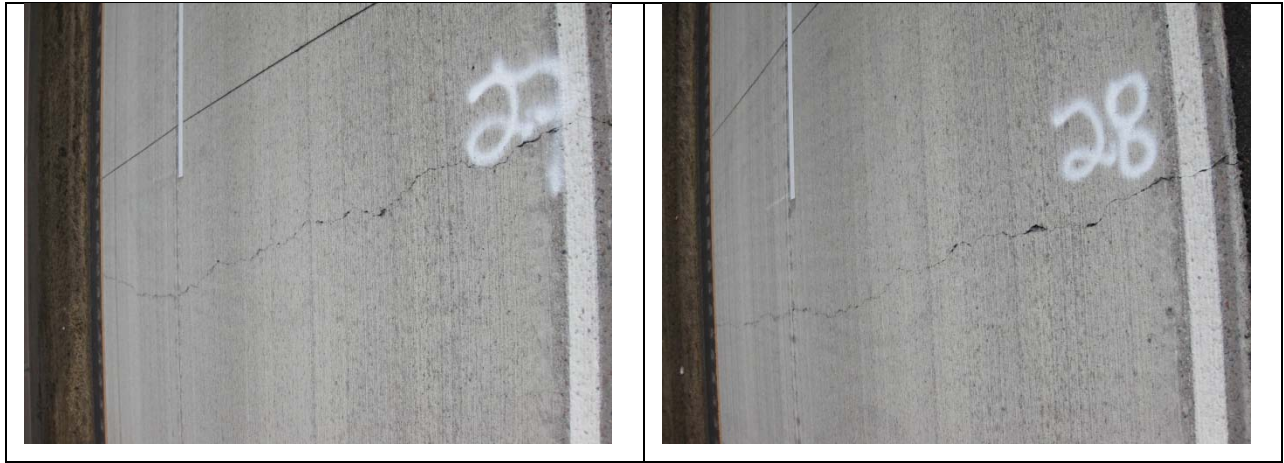

Figure A.14. Distress No. 27 [Left] & No. 28 [Right], April 2009

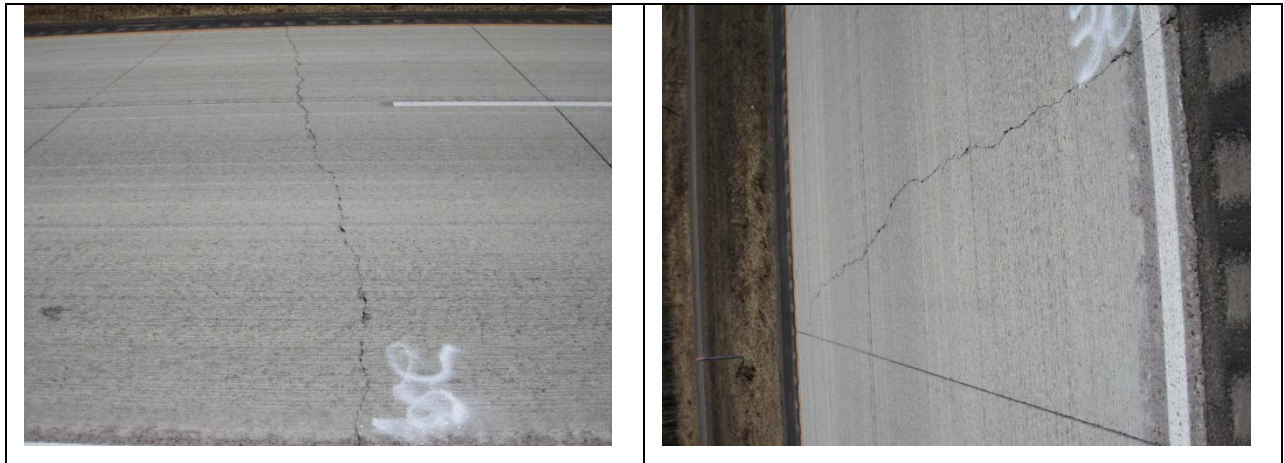

Figure A.15. Distress No. 29 [Left] & No. 30 [Right], April 2009



Figure A.16. Distress No. 31 [Left] & No. 32 [Right], April 2009



Figure A.17. Distress No. 33 [Left] & No. 34 [Right], April 2009

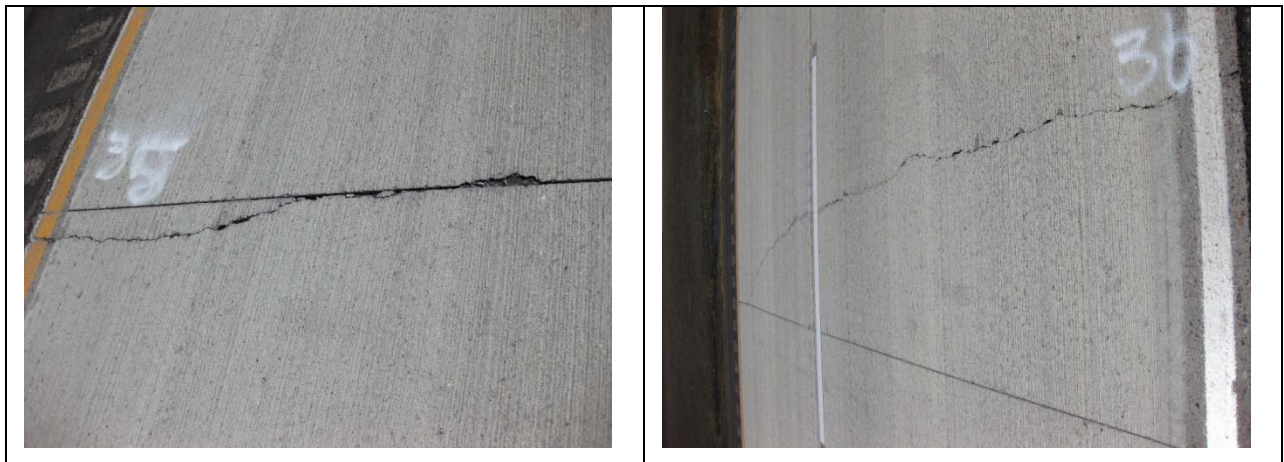

Figure A.18. Distress No. 35 [Left] & No. 36 [Right], April 2009



Figure A.19. Distress No. 37 [Left] & No. 38 [Right], April 2009

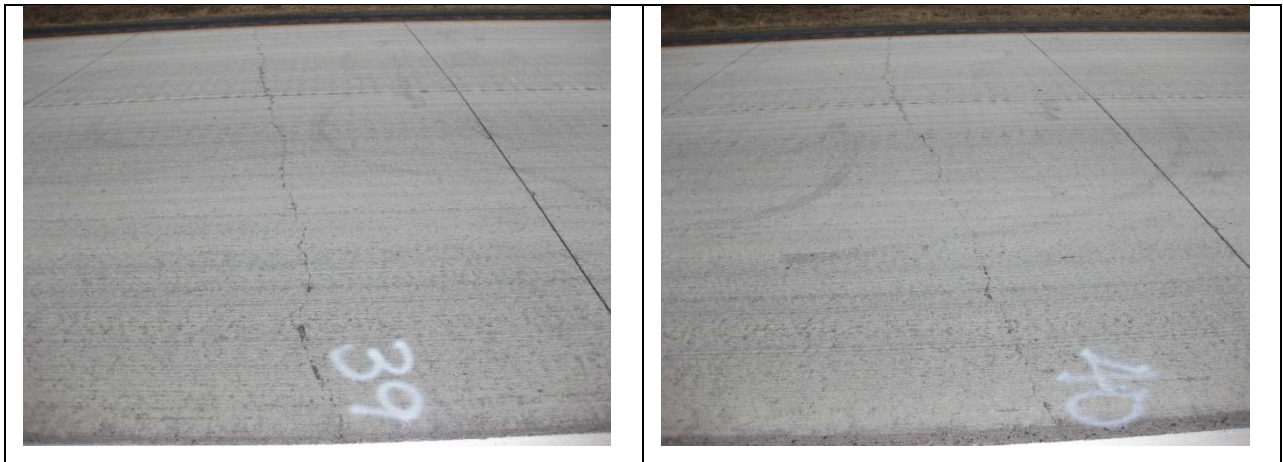

Figure A.20. Distress No. 39 [Left] & No. 40 [Right], April 2009



Figure A.21. Distress No. 41 [Left] & No. 42 [Right], April 2009