



RESEARCH

2007-28

Review of Georgia's Rural Intersection Crashes: Application of Methodology for Identifying Intersections for Intersection Decision Support (IDS)

Report #5 in the Series: Toward a Multi-State
Consensus on Rural Intersection Decision Support

Take the



steps...

Research...Knowledge...Innovative Solutions!

Transportation Research

Review of Georgia's Rural Intersection Crashes: Application of Methodology for Identifying Intersections for Intersection Decision Support (IDS)

Report #5 in the Series: Toward a Multi-State Consensus on
Rural Intersection Decision Support

Final Report

Prepared by:

Howard Preston, P.E.
Richard Storm, P.E., PTOE™
CH2M HILL

Max Donath
Craig Shankwitz
ITS Institute
University of Minnesota

July 2007

Published by:

Minnesota Department of Transportation
Research Services Section
395 John Ireland Boulevard, MS 330
St. Paul, Minnesota 55155-1899

This report represents the results of research conducted by the authors and does not necessarily represent the views or policies of the Minnesota Department of Transportation and/or the Center for Transportation Studies. This report does not contain a standard or specified technique.

Acknowledgements

The authors of this report would like to acknowledge and thank the states participating in the IDS Pooled Fund study. With the support of the following listed states, we have been able to further our study and gain a better understanding of crossing path crashes at rural unsignalized intersections:

- California
- Georgia
- Iowa
- Michigan
- Minnesota
- Nevada
- New Hampshire
- North Carolina
- Wisconsin

We would also like to especially acknowledge several individuals at the Georgia Department of Transportation (GDOT) who played key roles in the analysis of Georgia intersections and development of this report. We would like to thank Norm Cressman, Safety Program Manager in the Office of Traffic Safety & Design with GDOT, who provided the crash record information, supplied technical direction for the crash reviews, and participated in the intersection field reviews. The research team would also wish to acknowledge Yancy Bachmann, Assistant Traffic Safety and Design Engineer with GDOT, who participated in the field reviews. The authors also appreciate the traffic engineers from each district that met the field review team at the intersections. The additional information and background provided by the district staff on each of the intersections was crucial in the selection of the appropriate location for further study.

Finally, we wish to acknowledge the assistance provided by Ginny Crowson of the Minnesota Department of Transportation (Mn/DOT) who served as technical manager of the pooled fund project and Jim Klessig of Mn/DOT who served as administrative liaison of the pooled fund.

Table of Contents

1. Project Background	1
1.1. Typical Countermeasures for Rural Intersections.....	2
2. Crash Analysis Methods and Candidate Intersection Identification	4
3. Crash Record Review of Candidate Intersections.....	9
3.1. Correctable Crash Types.....	9
3.2. At-Fault Drivers	10
3.3. Crash Severity	13
3.4. Crash Location and Contributing Factors	14
3.5. Driver Recognition.....	16
3.6. Effect of Weather, Road Condition, and Light Condition.....	17
4. Field Review	21
4.1. GA 12 & GA 83 (#1, Morgan County).....	21
4.2. GA 21 & GA 275 (#2, Effingham County)	23
4.3. GA 54 & GA 154 (#3, Coweta County)	23
4.4. GA 61 & GA 140 (#4, Bartow County).....	25
5. Summary and Intersection Recommendation	27
5.1. Recommended Intersection for Deployment	27
5.2. Other Recommendations.....	29
References.....	31
Appendix A—Intersection Crash Diagrams	
Appendix B—Aerial Photographs	

List of Figures

Figure 1-1: Lag Selection Related Safety Strategies	3
Figure 2-1: Preferred Crash Analysis Process	4
Figure 2-2: Candidate Intersection Locations.....	8
Figure 3-1: GES Crossing Path Crash Types.....	10
Figure 3-2: At-Fault Driver Age of Correctable Crash Types at Candidate Intersections – 2000-2002.....	11
Figure 3-3: At-Fault Driver Age of Correctable Crash Types at Candidate Intersections – 2000-2005.....	13
Figure 3-4: Crash Severity of Correctable Crash Types at Candidate Intersections – 2000-2002.....	14
Figure 3-5: Crash Severity of Correctable Crash Types at Candidate Intersections – 2000-2005.....	15
Figure 3-6: Crash Location of Correctable Crash Types at Candidate Intersections – 2000-2002.....	16
Figure 3-7: Crash Location of Correctable Crash Types at Candidate Intersections – 2000-2005.....	17
Figure 3-8: Contributing Factors of Correctable Crash Types at Candidate Intersections – 2000-2002.....	18
Figure 3-9: Contributing Factors of Correctable Crash Types at Candidate Intersections – 2000-2005.....	19
Figure 4-1: Aerial Photo of GA 12 & GA 83	22
Figure 4-2: Looking North Toward Confederate Road and Pennington Road Approaches.....	22
Figure 4-3: Looking West and East from GA 83 Approach.....	23
Figure 4-4: Northbound Approach of GA 83	23
Figure 4-5: On GA 54 Looking North at Candidate Intersection	24
Figure 4-6: On West Approach of GA 154, Improved Sight Distance if Driver Creeps Past STOP Sign.....	24
Figure 4-7: Looking South and North from East Approach of GA 140	25
Figure 4-8: GA 140 Eastbound Approach and Channelized Right Turn Lane.....	25
Figure 4-9: View of Railroad Crossing from the East Approach of GA 140	26

List of Tables

Table 2-1: Georgia Intersection Summary Table.....	6-7
Table 3-1: Potential Correctable Crashes for IDS System at Candidate Intersections	10
Table 3-2: Distance from Crash Location to At-Fault Driver’s Residence	13
Table 3-3: Weather Condition Distribution for Crossing Path Crashes at Candidate Intersections	18
Table 3-4: Roadway Surface Condition Distribution for Crossing Path Crashes at Candidate Intersections	19
Table 3-5: Light Condition Distribution for Crossing Path Crashes at Candidate Intersections...	20
Table 5-1: Georgia Intersection Summary – 2000-2002	28
Table 5-2: Georgia Intersection Summary – 2000-2005	29

Executive Summary

The objective of the Intersection Decision Support (IDS) research project, sponsored by a consortium of states (Minnesota, California, and Virginia) and the Federal Highway Administration (FHWA), is to improve intersection safety. The Minnesota team's focus is to develop a better understanding of the causes of crashes at rural unsignalized intersections and then develop a solution to address the cause(s).

In the original study, a review of Minnesota's rural crash records and of past research identified poor driver lag selection as a major contributing cause of rural intersection crashes. Consequently, the design of the rural IDS system has focused on enhancing the driver's ability to successfully negotiate rural intersections by communicating information about the safety of the lags in the traffic stream to the driver.

Based on the Minnesota crash analysis, one intersection was identified for instrumentation (collection of driver behavior information) and the IDS system is under development. Also underway, alternative Driver Infrastructure Interfaces (DII) designs are being tested in a driving simulator at the University of Minnesota.

In order to develop an IDS system that has the potential to be nationally deployed, the regional differences at rural intersections must first be understood. Only then can a universal solution be designed and evaluated. To achieve this goal of national consensus and deployment, the University of Minnesota and the Minnesota Department of Transportation (Mn/DOT) initiated a State Pooled Fund study, in which nine states are cooperating on intersection-crash research. The participating states are:

- California
- Georgia
- Iowa
- Michigan
- Minnesota
- Nevada
- New Hampshire
- North Carolina
- Wisconsin

The first facet of this pooled fund project is a review of intersection crash data from each participating state, applying methods developed in previous IDS research. The crash data will be used to understand rural intersection crashes on a national basis, and to identify candidate intersections for subsequent instrumentation and study. The second facet is to instrument one candidate intersection in each participating state, as a means to acquire data regarding the behavior of drivers at rural intersections over a wide geographical base. States choosing to instrument intersections will be well positioned to reap the benefits of the new Cooperative Intersection Collision Avoidance System (CICAS) research funded by the United States Department of Transportation (USDOT) and the Mn/DOT. The CICAS Stop Sign Assist Program will investigate the human factors and technical considerations associated with the proposed IDS approach used to communicate with the driver at the intersection. A planned Field Operational Test will be designed to evaluate the performance of these systems.

Thus far in the states where the crash analysis is completed, the states where the focus was on rural, four-lane expressways (i.e., divided roadways) were Iowa, Minnesota, North Carolina and Wisconsin. While the states with a focus on two-lane highways (i.e., undivided) include Georgia and Michigan.

Review of Georgia's Intersections

This report documents the initial phase of the pooled fund study for the State of Georgia. The crash analysis focused on thru-STOP intersections of two-lane US or State routes that intersect two-lane US or State Routes in rural areas throughout Georgia.

Based on an analysis of these intersections from across the state, locations with twenty or more crashes between January 1, 2000 and December 31, 2002 were selected for further review. This resulted in a list of twenty intersections as candidates for further study, all of which were found to have a crash rate equal to or greater than the critical crash rate. For the seven intersections with the greatest number of angle crashes, officer reports were then used to narrow down to the top four intersections. The remaining four intersections were all found to have a high percentage of crossing path crashes. The four intersections that best fit the criteria were:

1. GA 12 & GA 83
2. GA 21 & GA 275
3. GA 54 & GA 154
4. GA 61 & GA 140

A field visit revealed that the Georgia Department of Transportation had already deployed safety countermeasures at these intersections, specifically intersection lighting, STOP AHEAD sign and transverse rumble strips. However, these strategies would be most effective at addressing crashes in which the driver fails to recognize that he/she is approaching the intersection and thus runs the STOP sign. Neither countermeasure provides the driver with assistance in recognition and selection of safe lags in the stream of cross-traffic. Advanced route and guide signing is used at the intersections and one intersection had advance warning for a railroad crossing, both of which can help increase driver awareness to prevent run-the-stop crashes.

Examination of the crash data indicated that these strategies did prove effective at reducing run-the-STOP crashes since there were few of these crash types. However, the large numbers of crossing path crashes at the four candidate intersections were predominately associated with a driver's poor lag identification and selection.

Using the crash factors of at-fault driver age, crash severity, contributing factors associated with the driver, along with several other factors, the intersection selected as the overall best candidate for test deployment of the IDS system was GA 61 and GA 140. This intersection has one of the worst crash experiences, including the highest crash rate, the highest percentage of crashes that were classified as a crossing path crash, the only intersection with a fatal crash, the highest number of visible injury crashes, and a high percentage of lag recognition crashes.

1. Project Background

The objective of the Intersection Decision Support (IDS) research project, sponsored by a consortium of states (Minnesota, California, and Virginia) and the Federal Highway Administration (FHWA), is to improve intersection safety. The Minnesota team's focus is to develop a better understanding of the causes of crashes at rural unsignalized intersections and then develop a solution to address the cause(s).

In the original study, a review of Minnesota's rural crash records and of past research identified poor driver lag selection as a major contributing cause of rural intersection crashes. Consequently, the design of the rural IDS system has focused on enhancing the driver's ability to successfully negotiate rural intersections by communicating information about the safety of the lags in the traffic stream to the driver.

Based on the Minnesota crash analysis, one intersection was identified for instrumentation (collection of driver behavior information) and the IDS system is under development. Also underway, alternative Driver Infrastructure Interfaces (DII) designs are being tested in a driving simulator at the University of Minnesota.

In order to develop an IDS system that has the potential to be nationally deployed, the regional differences at rural intersections must first be understood. Only then can a universal solution be designed and evaluated. To achieve this goal of national consensus and deployment, the University of Minnesota and the Minnesota Department of Transportation (Mn/DOT) initiated a State Pooled Fund study, in which nine states are cooperating on intersection-crash research. The participating states are:

- California
- Georgia
- Iowa
- Michigan
- Minnesota
- Nevada
- New Hampshire
- North Carolina
- Wisconsin

The first facet of this pooled fund project is a review of intersection crash data from each participating state, applying methods developed in previous IDS research. The crash data will be used to understand rural intersection crashes on a national basis, and to identify candidate intersections for subsequent instrumentation and study. The second facet is to instrument one candidate intersection in each participating state, as a means to acquire data regarding the behavior of drivers at rural intersections over a wide geographical base. States choosing to instrument intersections will be well positioned to reap the benefits of the new Cooperative Intersection Collision Avoidance System (CICAS) research funded by the United States Department of Transportation (USDOT) and the Mn/DOT. The CICAS Stop Sign Assist Program will investigate the human factors and technical considerations associated with the proposed IDS approach used to communicate with the driver at the intersection. A planned Field Operational Test will be designed to evaluate the performance of these systems.

This technical memorandum documents the initial phase of the pool fund study for the State of Georgia. Following is a description of the crash analysis performed for Georgia and a recommendation of an intersection as a test site for studying driver entry behavior. The data acquired from this site and from other selected intersections across the country will provide information needed to design an IDS system for national deployment.

1.1. Typical Countermeasures for Rural Intersections

A typical crossing path crash (i.e., right angle) crash at a rural unsignalized intersection is most often caused by the driver's (on a minor street approach) inability to recognize the intersection (which consequently results in a run the STOP sign violation), or his/her inability to recognize and select a safe lag in the major street traffic stream.

Traditional safety countermeasures deployed at rural high crash intersections include:

- Upgrading traffic control devices
 - Larger STOP signs
 - Multiple STOP signs
 - Advance warning signs and pavement markings
- Minor geometric improvements
 - Free right turn islands
 - Center splitter islands
 - Off-set right turn lanes
- Installing supplementary devices
 - Flashing beacons mounted on the STOP signs
 - Overhead flashing beacons
 - Street lighting
 - Transverse rumble strips

All of these countermeasures are relatively low cost and easy to deploy, but are typically designed to assist drivers with intersection recognition and have not exhibited an ability to address lag recognition problems. Yet, up to 80% of crossing path crashes are related to selection of an insufficient lag (1). In addition, a Minnesota study of rural thru-STOP intersections for rural two-lane roadways found only one-quarter of right angle crashes were caused by the driver on the minor street failing to stop because they did not recognize they were approaching an intersection (2). At the same set of intersections, 56% of the right angle crashes were related to selecting an unsafe lag while 17% were classified as other or unknown.

The concept of lag recognition being a key factor contributing to rural intersection safety appears to be a recent idea. As a result, there are relatively few devices in the traffic engineer's safety toolbox to assist drivers with lag recognition and they mainly consist of a few high cost geometric improvements and a variety of lower cost strategies that are considered to be experimental because they have not been widely used in rural applications. **Figure 1-1** illustrates the range of strategies currently available to address safety deficiencies associated with lag recognition problems, organized in order of the estimated cost to deploy (based on Minnesota conditions and typical implementation costs). The strategies include:

- The use of supplemental devices such as street light poles to mark the threshold between safe and unsafe lags
- Minor geometric improvements to reduce conflicts at intersection such as inside acceleration lanes, channelized median openings to eliminate certain maneuvers (sometimes referred to as a J-Turn), or revising a 4-legged intersection to create off-set T's
- Installing a traffic signal to assign right-of-way to the minor street

- Major geometric improvements such as roundabout or grade separated interchanges to eliminate to reduce crossing conflicts. (Refer to *Rural Expressway Intersection Synthesis of Practice and Crash Analysis* for a review of various alternatives [4].)

The use of these strategies may not be appropriate, warranted or effective in all situations. Also, the construction cost or right of way may prove to be prohibitive at some locations. All of this combined with a recommendation in AASHTO’s Strategic Highway Safety Plan to investigate the use of technology to address rural intersection safety led to the on-going research to develop a cost-effective Intersection Decision Support (IDS) system, including a new driver interface. The IDS system is intended to be a relatively low cost strategy (similar to the cost of a traffic signal), but at the same time is technologically advanced, using roadside sensors and computers to track vehicles on the major road approaches, computers to process the tracking data and measure available lags and then using the driver interface to provide minor road traffic with real-time information as to when it is unsafe to enter the intersection.

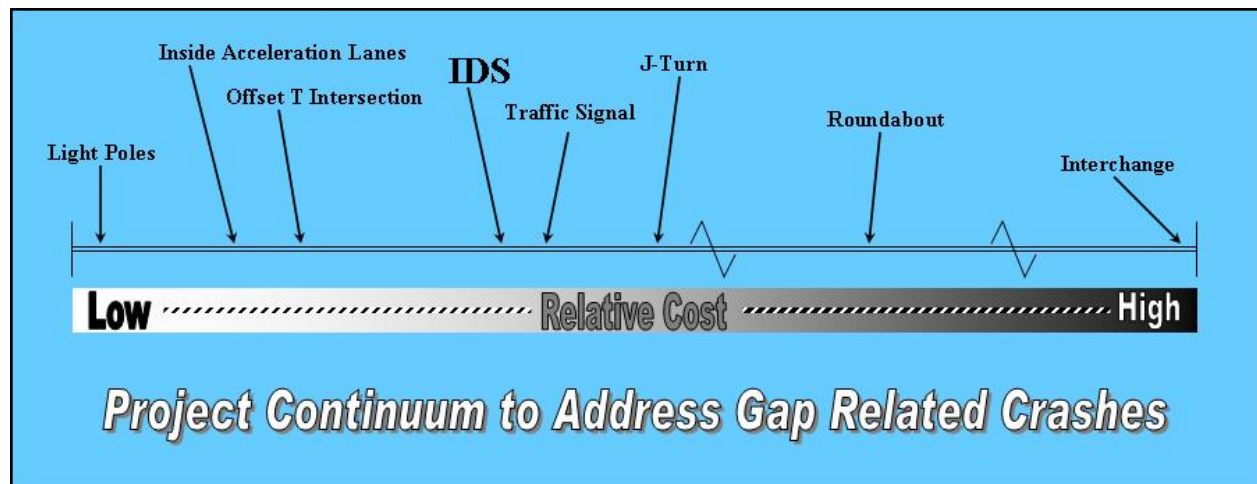

FIGURE 1-1
Lag Selection Related Safety Strategies

2. Crash Analysis Methods and Candidate Intersection Identification

A comprehensive method for intersection identification was developed using Minnesota's crash record system (see **Figure 2-1**).

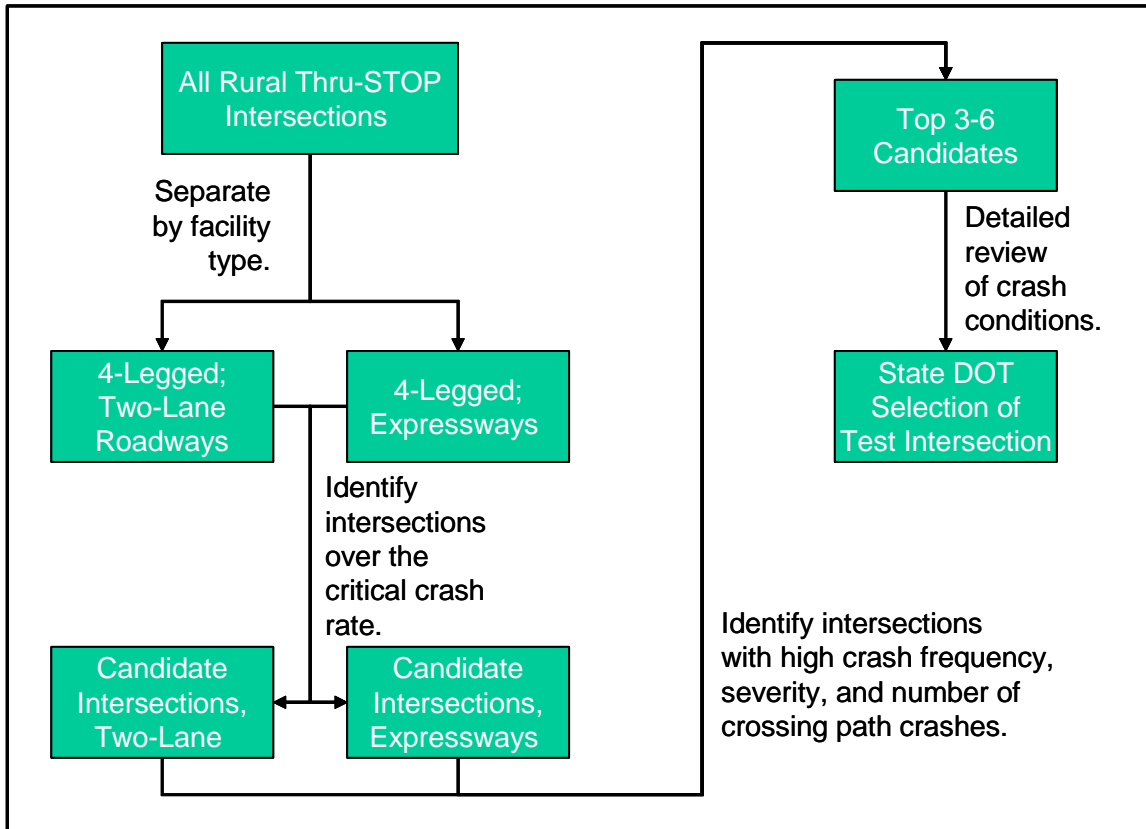

FIGURE 2-1
Preferred Crash Analysis Process

The method was applied to all rural, thru-STOP intersections in Minnesota, as this is the most frequent intersection situation in Minnesota. This intersection type is also the most likely where a driver will have to judge and select a lag at a rural intersection (i.e., stopped vehicle on the minor approach). The approach to identify the intersection selected for a potential field test of the technology used the three screens described in the following:

- **Critical Crash Rate** – The first screen was to identify the rural thru-STOP intersections that have a crash rate greater than the critical crash rate. The critical crash rate is a statistically significant rate higher than the statewide intersection crash rate. Therefore, any intersection with a crash rate equal to or above the critical crash rate can be identified as an intersection with a crash problem due to an existing safety deficiency.
- **Number and Severity of Correctable Crashes** – Once the intersections meeting the first criteria were identified, this second screen was performed to identify intersections where a relatively high number and percentage of crashes were potentially correctable by the

IDS technologies being developed. In Minnesota’s crash record system, “right angle” crashes were the crash type most often related to poor lag selection. Therefore the ideal candidate intersections had a high number and percentage of right angle collisions and tended to have more severe crashes. This screen was used to identify the top three candidate intersections for the final screen.

- **Crash Conditions and At-Fault Driver Characteristics** – The IDS system is believed to have the greatest benefit for older drivers. Therefore, the at-fault driver age was reviewed to identify intersections where older drivers were over represented. Other aspects of the crashes that were reviewed include whether the crashes were typically a problem with intersection recognition or lag recognition and the crash location (near lanes or far lanes).

In Georgia, application of the preferred process was not feasible due to the State DOT’s current crash record system. The State has no database of intersection characteristics (i.e., rural versus urban, traffic control device, roadway type, etc.) that is linked to the crash records. Essentially, Georgia is currently unable to automatically identify and query intersections (including crash records) based on physical characteristics and type of traffic control. Therefore, a modification of the approach was needed since it was impractical to manually search the State for all rural, thru-STOP intersections.

Modification of the preferred intersection selection process began with staff from the Georgia Department of Transportation (GDOT) selecting all crashes (January 1, 2000 through December 31, 2003) on US or State highways classified as rural and two-lane. Furthermore, crash records were selected only if the officer entered an intersecting US or State route, which also had to be classified as rural and two-lane. (NOTE: In IDS studies of the states completed to date, most states elected to focus on expressway intersections because the traditional solution to a lag-selection crash problem is to install a traffic signal, which will have significant impacts on mobility. However, Georgia was the second state that chose to focus on rural two-lane roads in the search for candidate locations.)

From this database of intersection crashes, the top 20 intersections based on crash frequency were identified (all locations had 20 or more crashes during the three-year study period). The crash database also provided information on distribution of crash type and crash severity for each location (**Table 2-1**). Using this information along with the crash rate and critical crash rate for each intersection, the seven intersections with the greatest number of angle crashes and had a crash rate of at least twice the critical crash rate were selected for further review—an evaluation of the officer reports. These were used to confirm that the crashes occurred at the intersection and which crashes were correctable (see **Chapter 3** for detailed description of correctable crash type) along with other data, such as at-fault driver’s age.

The review of the officer reports revealed that many of the crashes had occurred at other locations than first believed. This led to three intersections being removed from further consideration. The four intersections that best fit the selection criteria for a detailed investigation, including a field review, are (see **Figure 2-2** for intersection locations):

1. GA 12 and GA 83 (Morgan County)
2. GA 21 and GA 275 (Effingham County)
3. GA 54 and GA 154 (Coweta County)
4. GA 62 and GA 140 (Bartow County)

TABLE 2-1
Georgia Intersection Summary Table

Intersection of	County	Total Crashes	Entering ADT	Rate			Severity		
				Crash Rate	Expected Crash Rate	Critical Crash Rate	Fatal	Injury	PDO
Statewide Distribution							0.3%	26.2%	73.5%
GA 3 and GA 22 (N Jct)	Upson	17	4,275	3.6	0.4	1.0	0 0%	8 47%	9 53%
GA 8 and GA 316	Gwinnett	32	49,600	0.6	0.4	0.6	0 0%	6 19%	26 81%
GA 9 and GA 20	Forsyth	28	46,760	0.5	0.4	0.6	0 0%	1 4%	27 96%
GA 11 and GA 22	Jones	27	10,885	2.3	0.4	0.7	0 0%	2 7%	25 93%
GA 11 and GA 75	White	20	4,205	4.3	0.4	1.0	1 5%	4 20%	15 75%
GA 11 and GA 247SP	Houston	27	6,530	3.8	0.4	0.9	0 0%	9 33%	18 67%
GA 11 and GA 284	Hall	32	11,270	2.6	0.4	0.7	0 0%	5 16%	27 84%
GA 12 and GA 83	Morgan	31	9,276	3.1	0.4	0.8	0 0%	13 42%	18 58%
GA 14 and GA 154	Fulton	24	13,725	1.6	0.4	0.7	0 0%	4 17%	20 83%
GA 15 and GA 334	Jackson	26	13,460	1.8	0.4	0.7	0 0%	13 50%	13 50%
GA 21 and GA 275	Effingham	25	15,065	1.5	0.4	0.7	0 0%	15 60%	10 40%
GA 53 and GA 211	Hall	27	12,125	2.0	0.4	0.7	0 0%	7 26%	20 74%
GA 53 and GA 306	Forsyth	37	15,245	2.2	0.4	0.7	0 0%	12 32%	25 68%
GA 53 and GA 400	Dawson	38	27,700	1.3	0.4	0.6	0 0%	6 16%	32 84%
GA 54 and GA 154	Coweta	21	12,900	1.5	0.4	0.7	0 0%	6 29%	15 71%
GA 61 and GA 140	Bartow	34	8,620	3.6	0.4	0.8	0 0%	19 56%	15 44%
GA 75 and GA 384	White	20	9,010	2.0	0.4	0.8	1 5%	10 50%	9 45%
GA 81 and GA 316	Barrow	25	33,880	0.7	0.4	0.6	0 0%	11 44%	14 56%
GA 85 and GA 315	Harris	21	9,480	2.0	0.4	0.8	0 0%	7 33%	14 67%
GA 369 and GA 400	Forsyth	62	34,590	1.6	0.4	0.6	0 0%	7 11%	55 89%

NOTE:

- To calculate a critical crash rate, the statewide expected (i.e., average) crash rate for rural, thru-STOP intersections in Georgia was needed. This information was not available without a statewide database; therefore, the decision was made to use Minnesota’s statewide rate (0.4 crashes per million entering vehicle [MEV]) to estimate the critical crash rate.
- Green highlighted rows indicate the seven intersections for which officer crash reports were analyzed. The values for these seven intersections reflect the information used to select them for further study and do not include the corrections made after reviewing the officer reports.

TABLE 2-1 (continued)
Georgia Intersection Summary Table

Intersection of	County	Crash Type						Not a Collision with a Motor Vehicle	Unknown
		Angle	Head On	Rear End	Sideswipe - Same Direction	Sideswipe - Opposite Direction			
Statewide Distribution		28.1%	2.3%	38.4%	9.2%	2.3%	14.2%	5.4%	
GA 3 and GA 22 (N Jct)	Upson	2 12%	0 0%	0 0%	0 0%	0 0%	15 88%	0 0%	
GA 8 and GA 316	Gwinnett	3 9%	1 3%	27 84%	1 3%	0 0%	0 0%	0 0%	
GA 9 and GA 20	Forsyth	9 32%	0 0%	14 50%	2 7%	2 7%	1 4%	0 0%	
GA 11 and GA 22	Jones	1 4%	1 4%	20 74%	3 11%	1 4%	1 4%	0 0%	
GA 11 and GA 75	White	3 15%	1 5%	12 60%	2 10%	0 0%	2 10%	0 0%	
GA 11 and GA 247SP	Houston	9 33%	1 4%	11 41%	1 4%	0 0%	5 19%	0 0%	
GA 11 and GA 284	Hall	12 38%	0 0%	16 50%	3 9%	0 0%	1 3%	0 0%	
GA 12 and GA 83	Morgan	22 71%	0 0%	7 23%	1 3%	0 0%	1 3%	0 0%	
GA 14 and GA 154	Fulton	8 33%	1 4%	13 54%	1 4%	0 0%	1 4%	0 0%	
GA 15 and GA 334	Jackson	11 42%	2 8%	10 38%	0 0%	1 4%	2 8%	0 0%	
GA 21 and GA 275	Effingham	16 64%	0 0%	2 8%	1 4%	0 0%	6 24%	0 0%	
GA 53 and GA 211	Hall	9 33%	1 4%	10 37%	1 4%	0 0%	6 22%	0 0%	
GA 53 and GA 306	Forsyth	10 27%	1 3%	17 46%	1 3%	1 3%	7 19%	0 0%	
GA 53 and GA 400	Dawson	10 26%	0 0%	26 68%	2 5%	0 0%	0 0%	0 0%	
GA 54 and GA 154	Coweta	13 62%	1 5%	3 14%	0 0%	4 19%	0 0%	0 0%	
GA 61 and GA 140	Bartow	21 62%	3 9%	7 21%	0 0%	0 0%	3 9%	0 0%	
GA 75 and GA 384	White	6 30%	0 0%	9 45%	1 5%	1 5%	3 15%	0 0%	
GA 81 and GA 316	Barrow	11 44%	0 0%	12 48%	0 0%	1 4%	1 4%	0 0%	
GA 85 and GA 315	Harris	11 52%	0 0%	7 33%	1 5%	1 5%	1 5%	0 0%	
GA 369 and GA 400	Forsyth	9 15%	2 3%	44 71%	4 6%	0 0%	3 5%	0 0%	

NOTE:

- Green highlighted rows indicate the seven intersections for which officer crash reports were analyzed. The values for these seven intersections reflect the information used to select them for further study and do not include the corrections made after reviewing the officer reports.

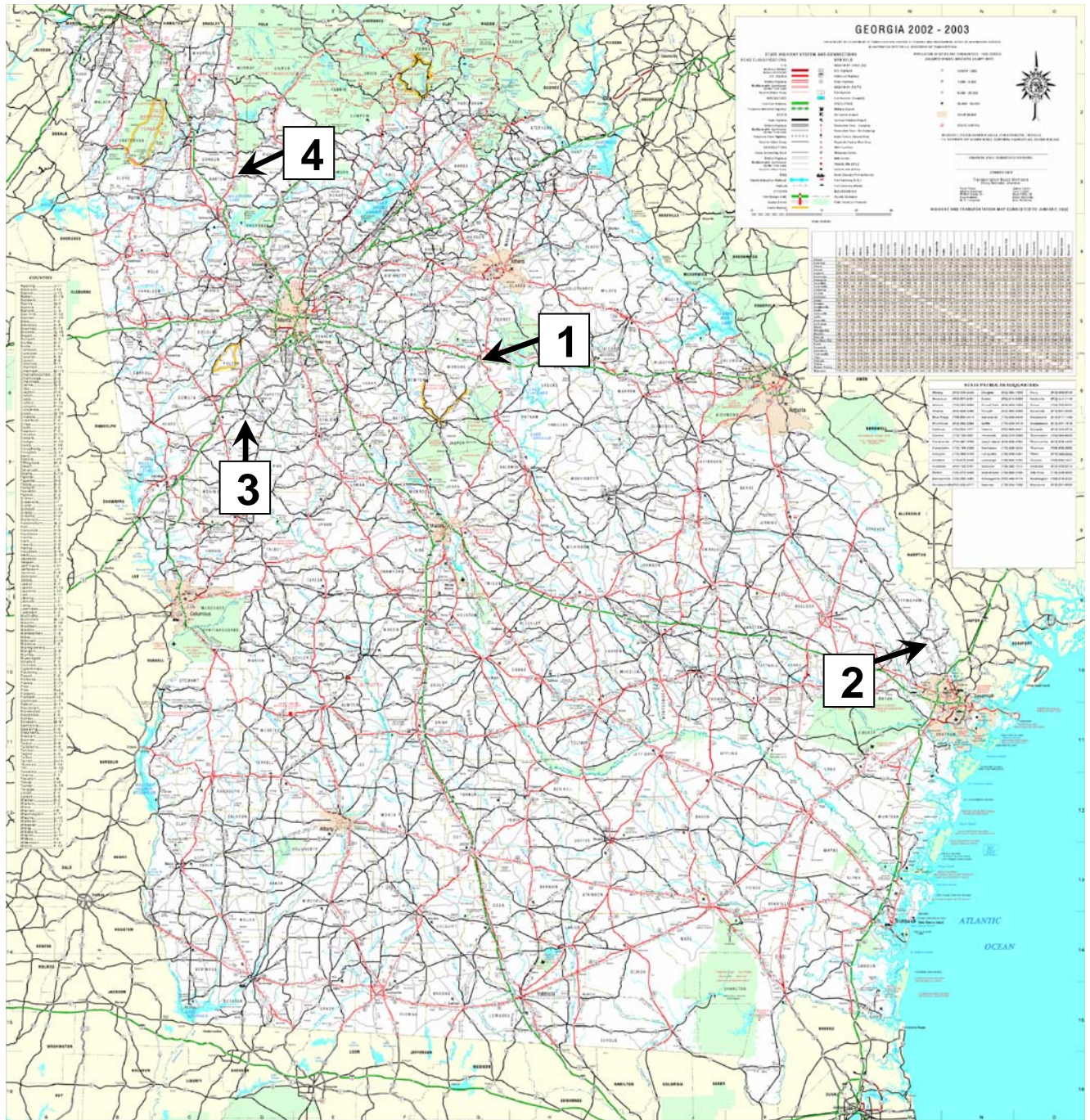

FIGURE 2-2
Candidate Intersection Locations

3. Crash Record Review of Candidate Intersections

It was already known that the four candidate intersections had high crash rates, high crash frequencies, and a high number of angle crashes, but the decision was made to investigate each intersection further for specific information pertinent to the IDS system and also to learn of any unusual circumstances at the intersections. At the candidate intersections, the factors reviewed included at-fault driver age, crash severity, crash location, contributing factors, and the effects of weather. For all of these summaries, the focus is on correctable crossing path crashes only (see following section for definition), which are the crash types that have the greatest potential to be corrected by the IDS system.

Special Note Regarding Crash Data Years: The initial crash analysis was completed in early 2005, prior to when complete crash data from 2003 and 2004 were available. Due to scheduling conflicts, the field visits weren't completed until the summer of 2006. It was at this time that the team learned two intersections (GA 21 & GA 275 [#2] and GA 54 & GA 154 [#3]) were programmed for improvements (refer to **Chapter 4** for more information). For the remaining two intersections, it was decided that the crash data analysis should be updated with crash information through September 30, 2005 so that the selection will be based on the most current information. Therefore, for the remainder of this report, crash information for the intersections of GA 21 & GA 275 (#2) and GA 54 & GA 154 (#3) include the years 2000-2002. Presented crash information for the intersections of GA 12 & GA 83 (#1) and GA 61 & GA 140 (#4) are for the years 2000-2002 (to allow comparison to all initial candidate intersections) and for 2000-2005 (updated information used for selection of the preferred location).

3.1. Correctable Crash Types

The General Estimates System (GES) crash database is a national sample of police-reported crashes used in many safety studies. In the GES, five crossing path crash types have been identified (see **Figure 3-1**), they are:

- Left Turn Across Path – Opposite Direction (LTAP/OD),
- Left Turn Across Path – Lateral Direction (LTAP/LD),
- Left Turn Into Path – Merge (LTIP),
- Right Turn Into Path – Merge (RTIP), and
- Straight Crossing Path (SCP).

At this time, the IDS system under development is intended to address the crash types involving at least one vehicle from the major and minor street, which includes all five GES crash types except for LTAP/OD. This research has not focused on the LTAP/OD crash type at unsignalized rural intersections because they are a relatively small problem. However, it is believed the system could be adapted to address LTAP/OD crashes if an intersection had a significant number of these crashes. For example, LTAP/OD crashes involving two vehicles from the minor street may be reduced if the device is designed to detect potential conflicts with vehicles from the opposing approach.

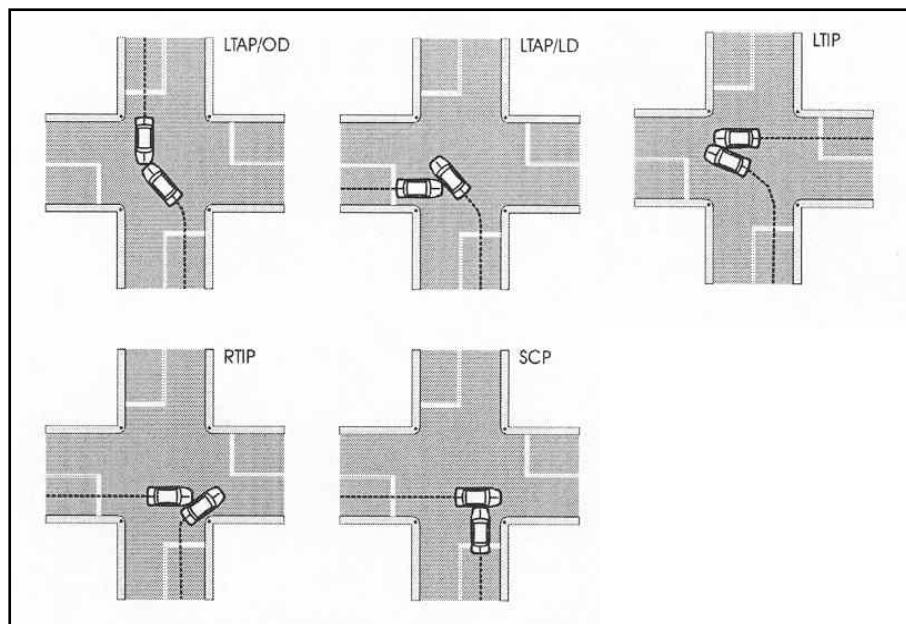

FIGURE 3-1
GES Crossing Path Crash Types

At the candidate intersections, the number and percent of correctable crashes is summarized in **Table 3-1**. As shown below, approximately 50% or more of the crashes at the four identified intersections are potentially correctable. GA 61 & GA 140 (#4) had the greatest number and percentage of correctable crashes in the initial three years reviewed (17 crashes) and also in the expanded study (27 crashes).

TABLE 3-1
Potential Correctable Crashes for IDS System at Candidate Intersections

	GA 12 & GA 83 (#1)	GA 21 & GA 275 (#2)	GA 54 & GA 154 (#3)	GA 61 & GA 140 (#4)
Number of Crashes	13 [26]	21	21	21 [34]
Number of Correctable Crashes	10 [15]	15	10	17 [27]
Percent of Crashes that are Correctable	77% [58%]	71%	48%	81% [79%]

NOTE: Correctable crashes have been defined as SCP, LTAP/LD, LTIP, and RTIP. Numbers in brackets represent crash total for the expanded study period; January 1, 2000 through September 30, 2005.

3.2. At-Fault Drivers

For each candidate intersection, all crash reports from January 1, 2000 to December 31, 2002 were reviewed to identify the driver whose action caused the accident, also known as the at-fault driver (see **Figure 3-2**). For the intersections of GA 12 & GA 83 (#1) and GA 61 & GA 140 (#4), the age distribution of the at-fault drivers for the expanded time frame can be found in

Figure 3-3. The age of the at-fault driver is important since the IDS system may have its greatest benefit in assisting older drivers in particular. From the 2002 Crash Analysis, Statistics & Information (CASI) Notebook (published by the Georgia Department of Motor Vehicle Safety), 14.5% of involved drivers were under the age of 21, 79.4% between the age of 20 and 64, and 6.0% over the age of 64. The Georgia CASI Notebook lists involved drivers and not specifically at-fault drivers. Because of the differences between involved drivers and at-fault drivers, comparisons between statewide involvement rates and the at-fault age distributions at the candidate intersections must be carefully considered.

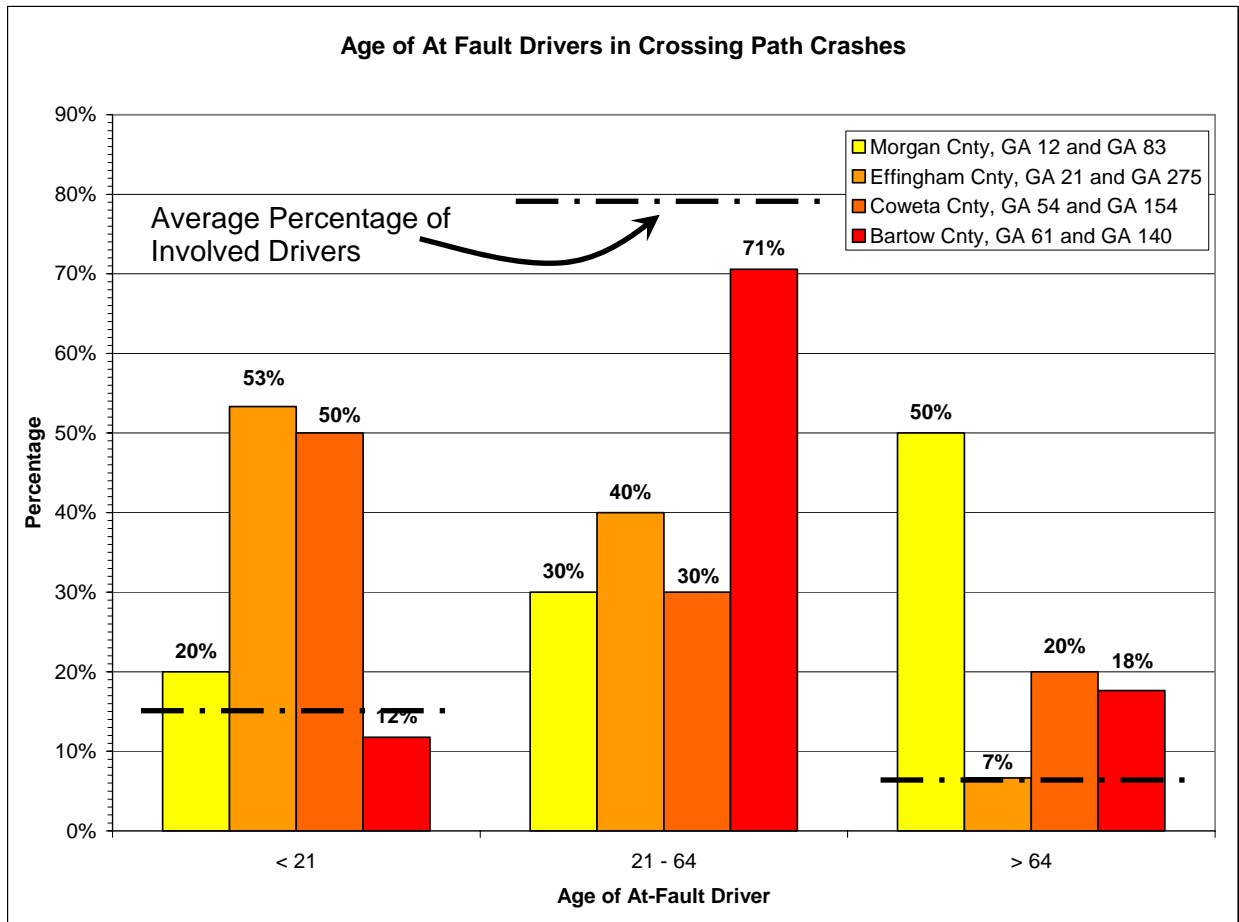

FIGURE 3-2

At-Fault Driver Age of Correctable Crash Types at Candidate Intersections – 2000-2002

NOTE: Expected values based on involved driver age of all crashes reported in 2002 Georgia CASI Notebook

Of the two intersections with no programmed improvements, the expanded crash data included in Figure 3-3 illustrates that the number of at-fault young drivers is close to the expected value. Furthermore, drivers between 21 and 64 are underrepresented while older drivers are overrepresented. Of the two intersections, GA 12 & GA 83 (#1) does have the highest percentage of at-fault older drivers, but the percentage of at-fault older drivers at both intersections is at least three times greater than the expected value.

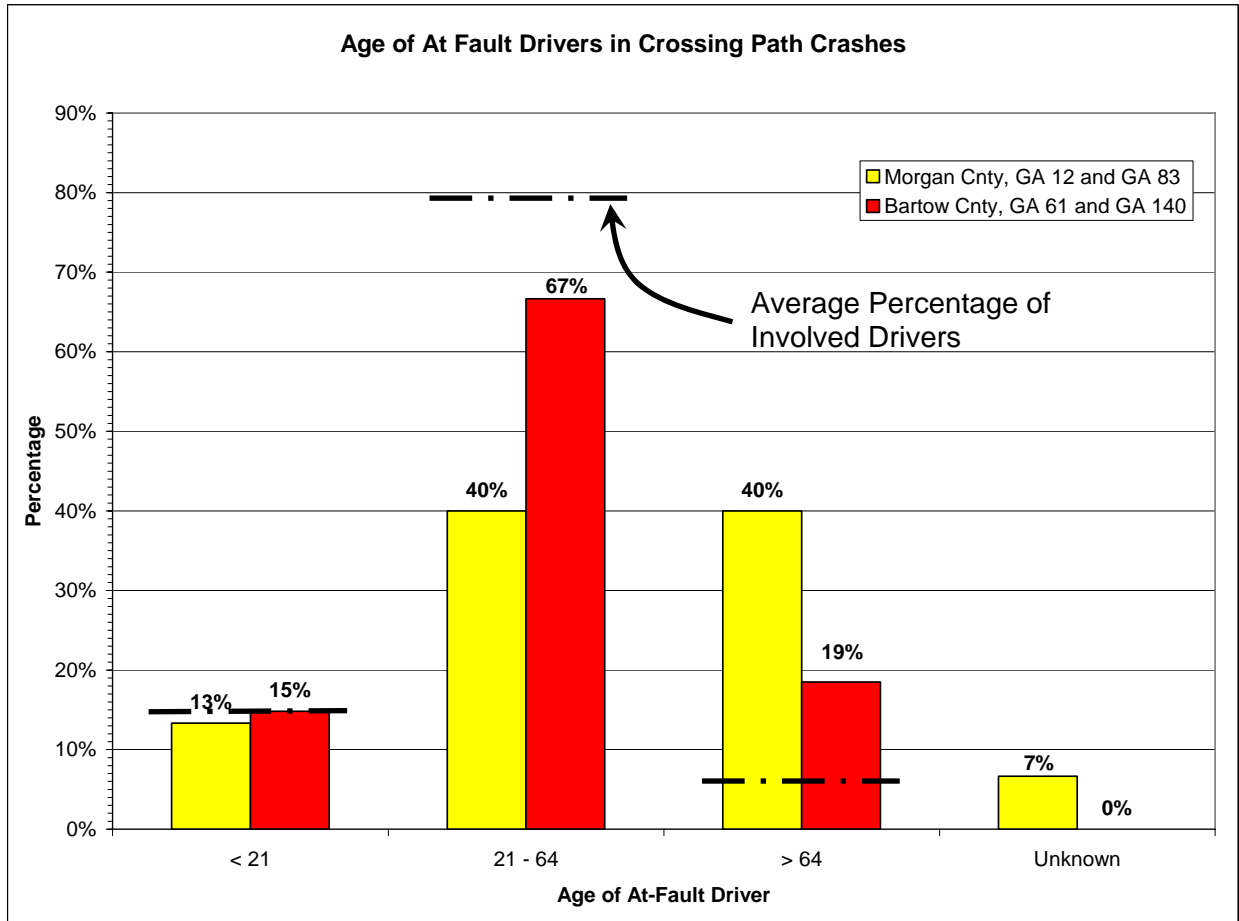

FIGURE 3-3

At-Fault Driver Age of Correctable Crash Types at Candidate Intersections – 2000-2005 (through September 30, 2005)

NOTE: Expected values based on involved driver age of all crashes reported in 2002 Georgia CASI Notebook

To assess whether the at-fault drivers are likely to be familiar with the intersection and enter it routinely, the distance from the crash location to their residence was examined. This can be an important factor if simulation testing reveals that drivers have a difficult time understanding the DII their first time through the intersection. If at-fault drivers are generally local residents, an educational program might be necessary and could be focused on the local population. However, if many of the at-fault drivers were not from the area and also did not have a high understanding of the DII, it is likely the IDS device would not have helped the driver avoid the crash.

In the initial crash review, it was discovered that most of the at-fault drivers were local to the area (i.e., 90% or more lived within 30 miles of the crash location) at two of the intersections— GA 21 & GA 275 (#2) and GA 54 & GA 154 (#3) (see **Table 3-2**). However, these are the two intersections programmed for future improvements and are not being considered for possible implementation of the IDS system. At the intersections of GA 12 & GA 83 (#1) and GA 61 & GA 140 (#4), less than 60% of the at-fault drivers were considered to be local to the area. This confirms a need that the DII for the IDS system should be easily understood, especially for drivers that experience the system for the first time.

TABLE 3-2

Distance from Crash Location to At-Fault Driver's Residence

	GA 12 & GA 83 (#1)	GA 21 & GA 275 (#2)	GA 54 & GA 154 (#3)	GA 61 & GA 140 (#4)
Median Distance	21 miles [21 miles]	5 miles	6 miles	51 miles [45 miles]
Average Distance	75 miles [94 miles]	7 miles	30 miles	103 miles [102 miles]
Minimum Distance	<1 mile [<1 mile]	2 miles	<1 mile	9 miles [9 miles]
Maximum Distance	503 miles [503 miles]	26 miles	246 miles	846 miles [846 miles]
Percent of Distances ≤ 10 miles	30% [29%]	87%	70%	12% [7%]
Percent of Distances ≤ 30 miles	70% [57%]	100%	90%	47% [44%]
Unknown Drivers (i.e., hit and run)	0 [1]	0	0	0 [0]

NOTE: Numbers in brackets represent crash total for the expanded study period; January 1, 2000 through September 30, 2005.

3.3. Crash Severity

Another goal of the IDS system is to address the most serious intersections crashes, especially fatal crashes. Therefore, the most appropriate candidate intersection would have a high percentage of fatal and injury crashes. Of Georgia's 2002 crashes, fatal crashes represented approximately 0.4% of all of crashes, with injury crashes at 24.9% and property damage (PD) crashes representing 74.6% of all crashes (Source: 2002 Georgia CASI Notebook). **Figure 3-4** shows the crash severity distribution for all four intersections between 2000 and 2002. For GA 12 & GA 83 (31) and GA 61 & GA 140 (#4), the crash severity distribution for through September 30, 2005 is in **Figure 3-5**.

Considering only the two intersections with no programmed improvement, the intersection of GA 61 & GA 140 (#4) was the only intersection to have a fatal crash (**Figure 3-5**). Both intersections had approximately an almost identical percentage of injury and property damage only crashes. Furthermore, the injury crashes at these two intersections was approximately twice what would be expected, while the property damage crashes at both intersections were well below the expected values.

Whether looking at three years of crash data for all four intersections or nearly five years of data for the two final candidates, the intersections have a crash severity higher than expected based on all crashes that occurred in Georgia in 2002. This supports the finding in the original IDS study (3) that crossing path crashes tend to be more severe than the average intersection crash.

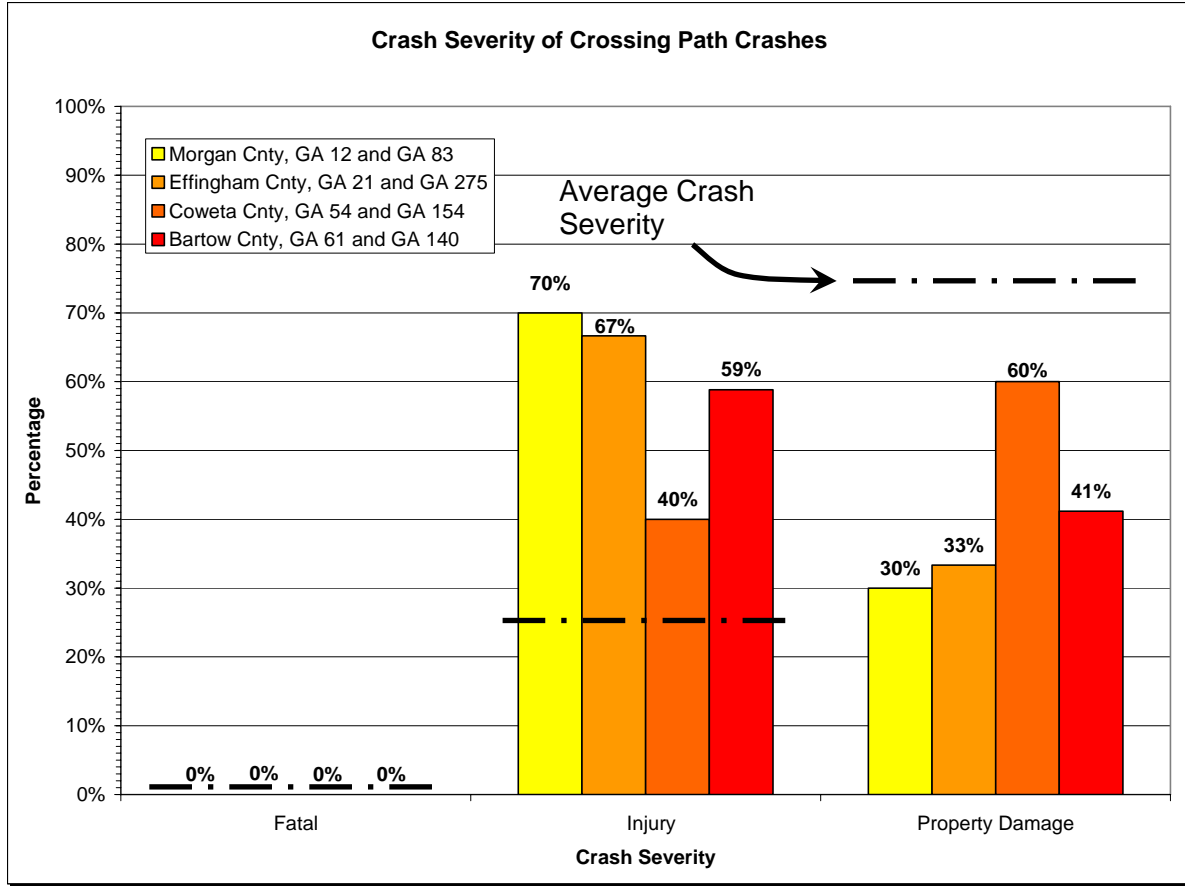

FIGURE 3-4

Crash Severity of Correctable Crash Types at Candidate Intersections – 2000-2002

NOTE: Expected values based on crash severity of all crashes reported in 2002 Georgia CASI Notebook

3.4. Crash Location and Contributing Factors

From the initial review of Minnesota’s crash records (3), it was observed that crossing path crashes at the candidate intersections were predominately on the far side of the intersection. [NOTE: For the divided expressway in Minnesota, a far-side crash occurs when the stopped vehicle safely negotiates the first two lanes it crosses, but is involved in a crash when leaving the median to either cross or merge into traffic in the second set of lanes.] The primary cause of the high number of far-side crashes was not evident from review of the crash records. However, it was speculated that drivers used a one-step process for crossing rather than a two-step process. When a driver enters the median, rather than stopping to reevaluate whether the lag is still safe (a two-step process), it is believed that drivers simply proceed into the far lanes without stopping (a one-step process). At the selected intersection in Minnesota (U.S. 52 and Goodhue County 9), vehicle detection equipment has already been installed along with video cameras. The information recorded at the intersection will be used to quantify how drivers typically cross this and similar intersections.

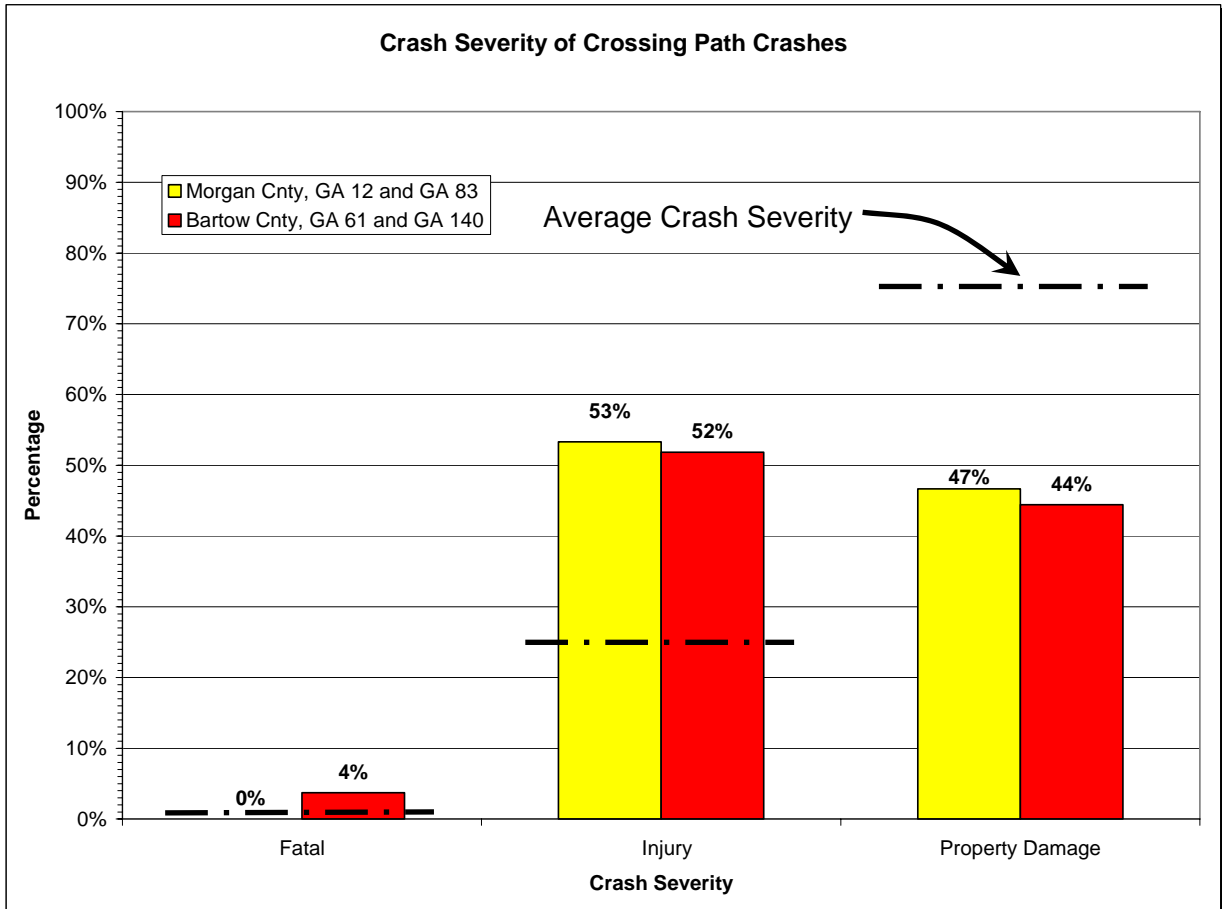

FIGURE 3-5

Crash Severity of Correctable Crash Types at Candidate Intersections – 2000-2005 (through September 30, 2005)

NOTE: Expected values based on involved driver age of all crashes reported in 2002 Georgia CASI Notebook

For the pooled fund study to date, rural expressway intersections in North Carolina, Wisconsin, and Iowa have been reviewed. For the candidate intersections in these states, the pattern was similar to what was observed in Minnesota with a majority of crossing path crashes occurring in the far lanes. The Georgia analysis differs from many of the states previously studied since Georgia is only the second state to focus on two-lane highways—Michigan was the first state. In this situation, it is necessary for the driver to complete a crossing maneuver (i.e., straight across or left turn) in one step since there is no median refuge. However, documenting this crash characteristic is the first step to understanding the contributing circumstances and any differences between intersections on expressways and two-lane highways.

At the Georgia candidate intersections (see **Figure 3-6** and **Figure 3-7**), three sites had a majority of the crossing path crashes on the farside [GA 21 & GA 275 (#2), GA 54 & GA 154 (#3), GA 61 & GA 140 (#4)] while the intersection of GA 12 & GA 83 (#1) had a strong pattern of nearside crashes. Using the expanded data, the pattern in crash locations at the intersections of GA 12 & GA 83 (#1) and GA 61 & GA 140 (#4) continue to exhibit crash characteristics opposite from each other.

In addition to Georgia and Michigan, the crash reviews in Nevada and New Hampshire will focus on two-lane highways instead of expressways. Information learned from these four states will help in understanding if the road type plays a factor in the crash location.

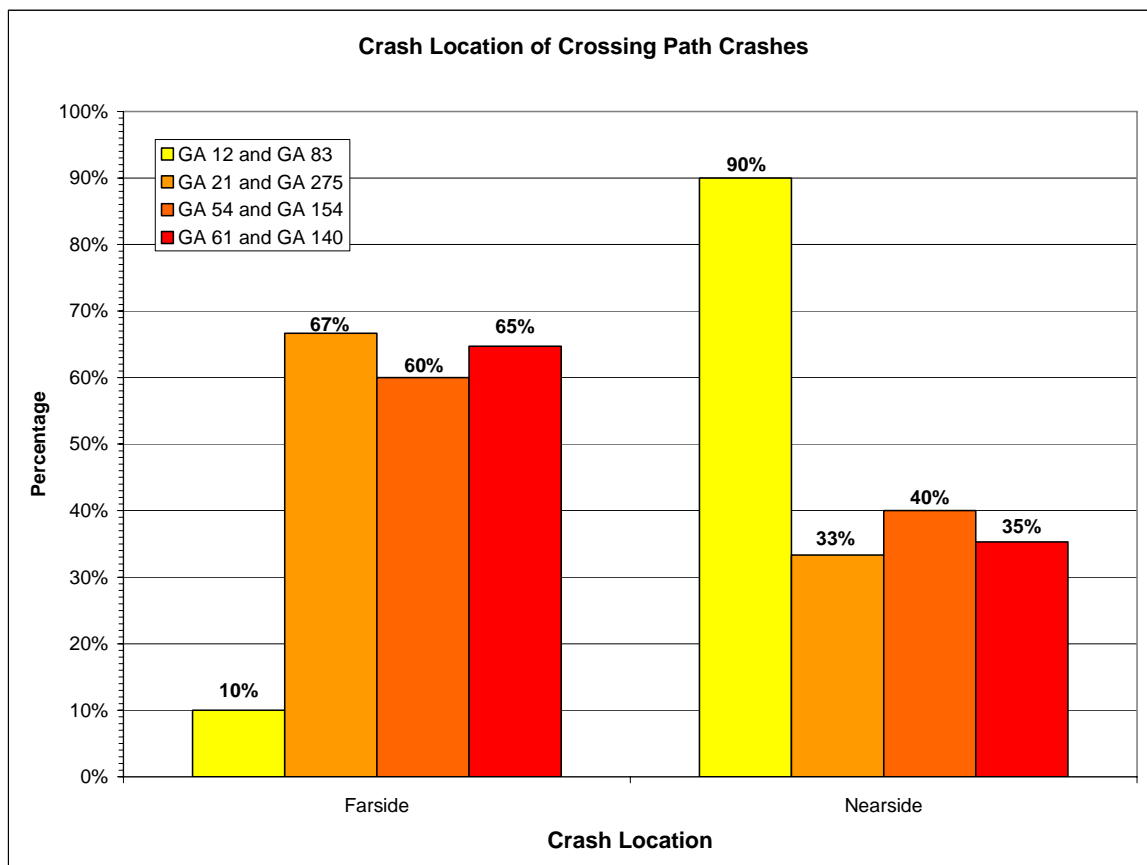

FIGURE 3-6
Crash Location of Correctable Crash Types at Candidate Intersections – 2000-2002

3.5. Driver Recognition

Another important crash characteristic is whether the at-fault driver failed to recognize the intersection (i.e., ran-the-STOP) or failed to select a safe lag (i.e., stopped, pulled out). Since the IDS device is primarily intended to help drivers with selecting safe lags, crashes where the driver ran-the-STOP may not be correctable by the proposed IDS system. To classify the crashes as either intersection recognition or lag recognition, the narratives on the officer reports were reviewed. However, some narratives did not specifically state whether the driver stopped at the STOP sign, in which case they may have been classified as “unknown.” However, for many of these situations, the officer’s narrative provided enough information to make a determination as to whether or not the driver recognized the intersection. For example, the officer may have reported that the driver was turning onto the highway. Even though the officer did not comment if the driver stopped, their decision to turn at the intersection is a strong indication that they were aware of the intersection but were unable to select a safe lag. This scenario would have been classified as a lag recognition crash. Further, most of the crossing path crashes where the driver

recognition was classified as other/unknown were situations where the at-fault driver reported that they believed the intersection was an all-way stopped controlled location. They then pulled into the intersection assuming that oncoming vehicles had to stop.

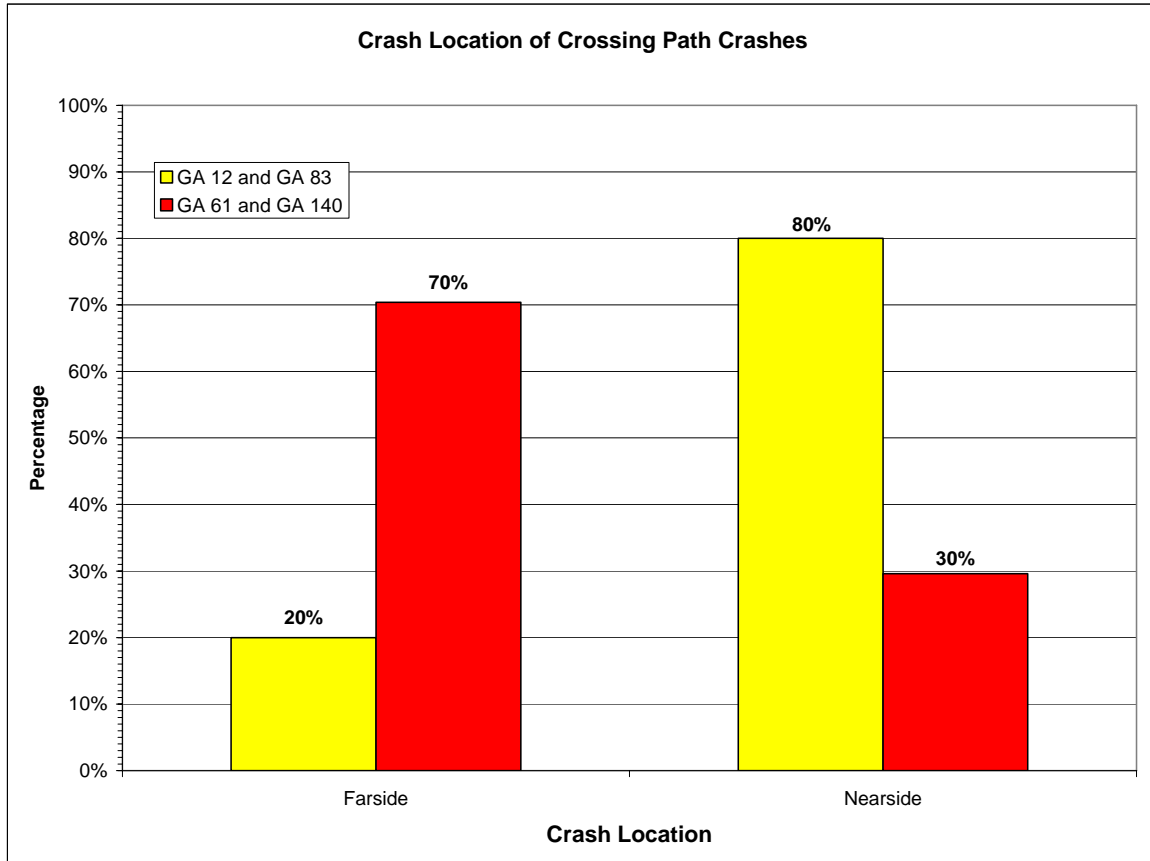

FIGURE 3-7
Crash Location of Correctable Crash Types at Candidate Intersections – 2000-2005
(through September 30, 2005)

As shown in **Figure 3-8** and **Figure 3-9**, over 80% of the crossing path crashes at all four intersections were lag recognition crashes. This strongly suggests that a high percentage of these crashes could have been prevented if the drivers had assistance in identifying, judging and selecting a safe lag.

3.6. Effect of Weather, Road Condition, and Light Condition

The final factors reviewed for the crossing path crashes at each candidate intersection were the weather, road, and light conditions. If the crashes tended to occur during adverse weather conditions (i.e., snow, rain, dark), then deployment of a new technology may have a limited benefit unless it can be coordinated with a local RWIS station.

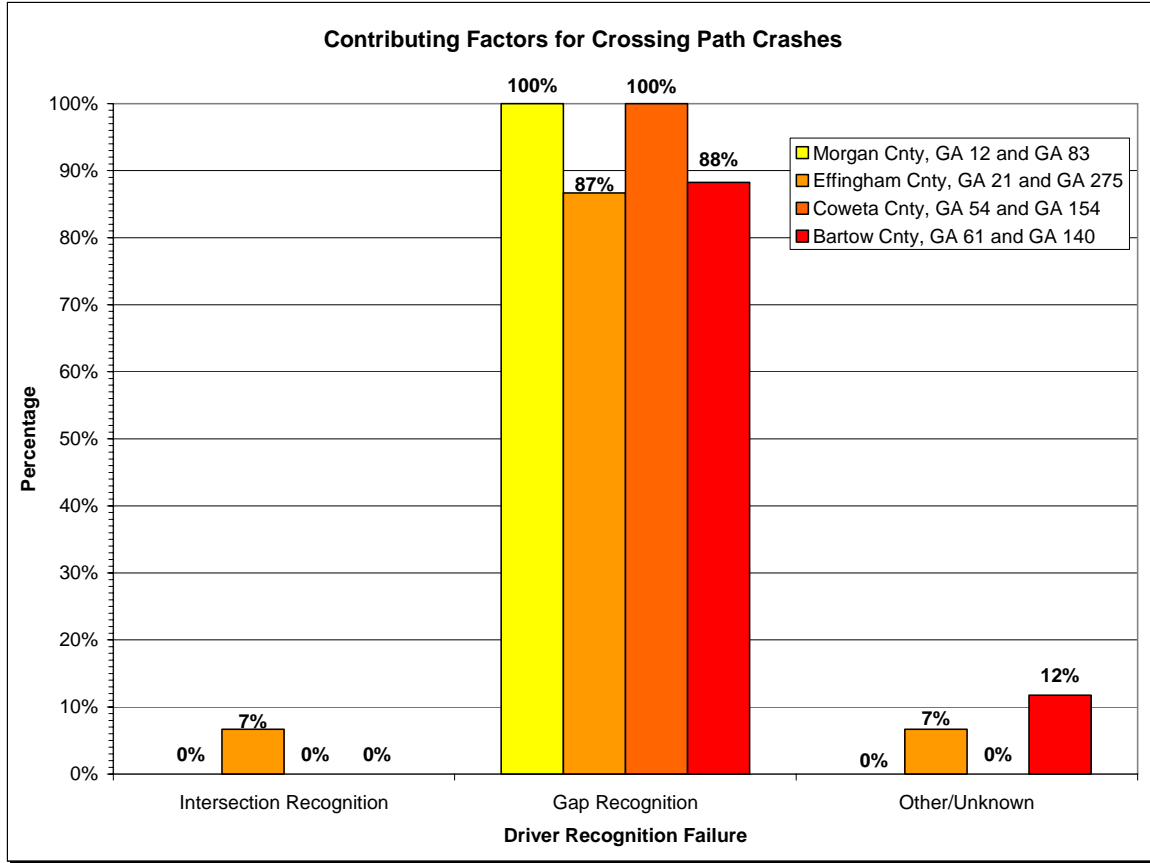

FIGURE 3-8
Contributing Factors of Correctable Crash Types at Candidate Intersections – 2000-2002

For the weather condition (see **Table 3-3**), nearly 90% or more of the crossing path crashes occurred during good weather conditions. This indicates that weather is, at most, only a minor contributing factor to the crossing path crashes that occurred at the candidate intersections.

TABLE 3-3
Weather Condition Distribution for Crossing Path Crashes at Candidate Intersections

	GA 12 & GA 83 (#1)	GA 21 & GA 275 (#2)	GA 54 & GA 154 (#3)	GA 61 & GA 140 (#4)
Clear or Cloudy	100% [93%]	87%	100%	88% [93%]
Rain	0% [7%]	13%	0%	12% [7%]
Snow or Sleet	0% [0%]	0%	0%	0% [0%]
Other/ Unknown	0% [0%]	0%	0%	0% [0%]

NOTE: Numbers in brackets represent crash total for the expanded study period; January 1, 2000 through September 30, 2005.

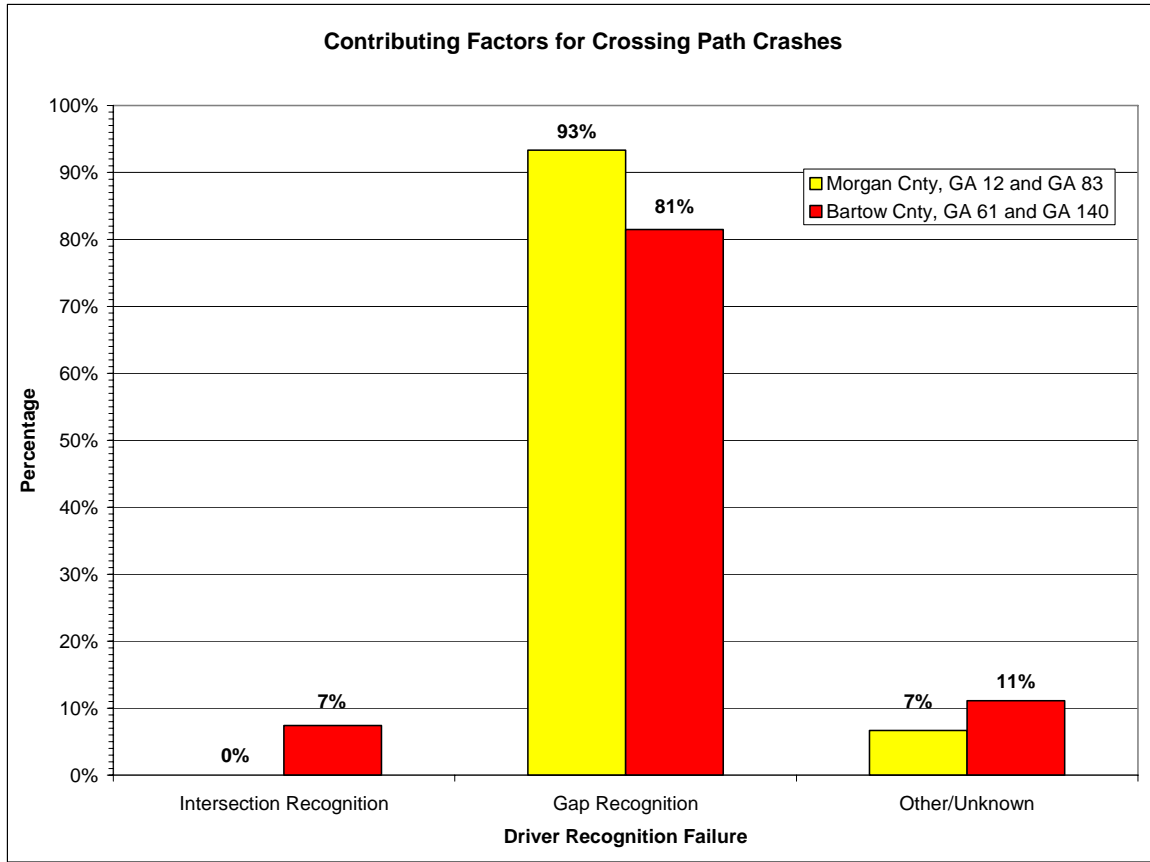

FIGURE 3-9
Contributing Factors of Correctable Crash Types at Candidate Intersections – 2000-2005 (through September 30, 2005)

Regarding the road surface conditions, **Table 3-4** shows that 80-90% of crossing path crashes at all four candidate intersections occurred on dry pavement; and approximately 10-20% of crashes at all intersections occurred on wet pavement. None of the intersections had snow or ice conditions during the recorded crashes.

TABLE 3-4
Roadway Surface Condition Distribution for Crossing Path Crashes at Candidate Intersections

	GA 12 & GA 83 (#1)	GA 21 & GA 275 (#2)	GA 54 & GA 154 (#3)	GA 61 & GA 140 (#4)
Dry	90% [87%]	80%	90%	82% [85%]
Wet	10% [13%]	20%	10%	18% [15%]
Snow or Ice	0% [0%]	0%	0%	0% [0%]
Other/Unknown	0% [0%]	0%	0%	0% [0%]

NOTE: Numbers in brackets represent crash total for the expanded study period; January 1, 2000 through September 30, 2005.

The percentage of crossing path crashes reported during daylight conditions at all four intersections was at or above 85% (see **Table 4-5**). Further, none of the intersections had a percentage of crossing path crashes during dark conditions that was much above 10%, indicating that a majority of the at-fault drivers should have had plenty of light to identify approaching vehicles.

TABLE 3-5
Light Condition Distribution for Crossing Path Crashes at Candidate Intersections

	GA 12 & GA 83 (#1)	GA 21 & GA 275 (#2)	GA 54 & GA 154 (#3)	GA 61 & GA 140 (#4)
Daylight	90% [93%]	100%	90%	94% [85%]
Dawn or Dusk	0% [0%]	0%	0%	0% [4%]
Dark	10% [7%]	0%	10%	6% [11%]
Other/ Unknown	0% [0%]	0%	0%	0% [0%]

NOTE: Numbers in brackets represent crash total for the expanded study period; January 1, 2000 through September 30, 2005.

4. Field Review

On May 22, 2006, field reviews for three of the four candidate intersections were performed. The three intersections reviewed were GA 12 & GA 83(#1), GA 54 & GA 154 (#3), and GA 61 & GA 140 (#4). A field review was not conducted at this time for the intersection at GA 21 & GA 275 (#2) because it was not in close proximity to the other three intersections. Some of the general observations made during the field review include:

- The typical minor street approach (stopped approach) was a single lane, and may have included a few safety countermeasures, specifically a STOP AHEAD sign or transverse rumble strips.
- Intersection lighting, advanced route or guide signing, and railroad crossing markings were often in place and may assist drivers with intersection recognition.
- Power is readily available at all intersections to operate an IDS system.
- The intersection sight distance was typically at or above the recommended values. However, at some of the stopped approaches, a vehicle may have to creep past the STOP sign in order to have a clear view of the through roadway/traffic.

Following is a brief description of each of the intersections. For each intersection, crash diagrams are included in **Appendix A** and aerial photos are in **Appendix B**.

4.1. GA 12 & GA 83 (#1, Morgan County)

The intersection is located in Morgan County, on the western fringe of the community Madison (2000 Census Population = 3,600). GA 12 (also marked as US Highway 278) proceeds directly to the center of Madison and is an important route for the local communities. Since the intersection is on the outskirts of Madison, several retail businesses are located in the vicinity of the intersection, which are visible in **Figure 4-1**. The intersection's most notable characteristic is that the intersection has five legs, two of which are closely spaced streets—Confederate Road and Pennington Road—on the north side of GA 12 (see **Figure 4-2**). This arrangement creates complications for drivers stopped on any of the minor streets (Confederate Road and Pennington Road on the north side of GA 12, and GA 83 on the south side of GA 12).

It was observed during the field review that a major movement for traffic approaching the intersection on GA 83 is to turn right, towards Madison. There were also many vehicles leaving Madison (going west on GA 12) that were turning left onto GA 83 southbound, likely heading to I-20 located a few miles to the south. At the time of the field review, the traffic volumes on GA 12 were also observed to be high enough that there were a limited number of lags available for vehicles stopped and waiting to cross or turn onto GA 12 (see **Figure 4-3**).

The intersection is located on a horizontal curve along GA 12, which is visible in the aerial photo. However, the photos in **Figure 4-3** show that available sight distance is acceptable. The west approach of GA 12 also has a small crest vertical curve which can hide a vehicle on the other side of the crest (left photo of **Figure 4-3**), but timings made the morning of the field review revealed that ten seconds of sight distance was generally still available for approaching vehicles. Observed improvements to the intersection include transverse rumble strips on the Confederate Road approach. There is also a channelized right turn lane for northbound GA 83 (**Figure 4-4**) with a YIELD sign.

Confederate Road and Pennington Road are both local streets that have relatively low volumes, especially when compared to GA 83. This likely explains why most crossing path crashes involve a vehicle from the GA 83 approach instead of the Confederate Road or Pennington Road approaches (see crash diagrams in **Appendix A**). However, it is still not clear why most crossing path crashes involved a vehicle on the west approach of GA 12. One possible explanation is that the small crest vertical curve to the west of the intersection is giving drivers difficulties selecting lags, even though generally ten seconds of sight distance is available.

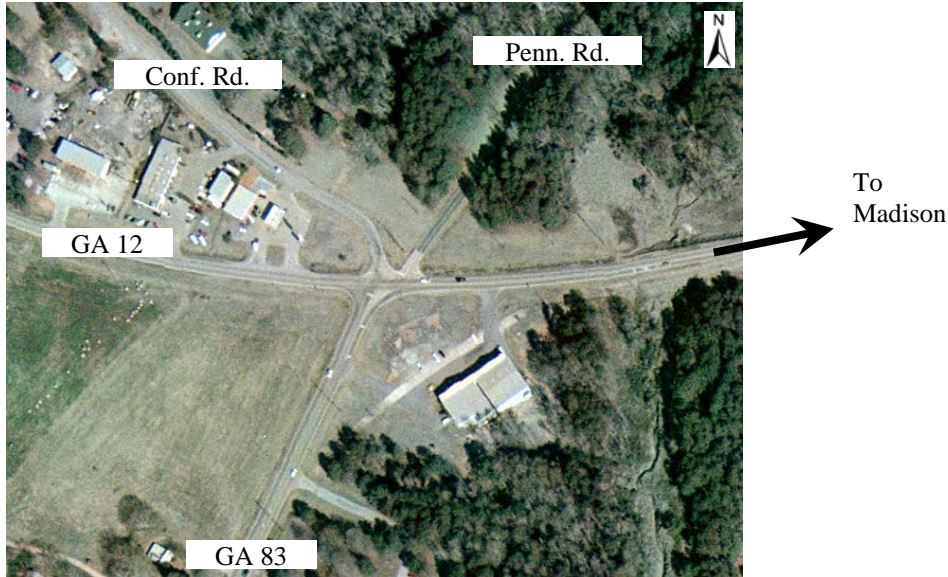

FIGURE 4-1
Aerial Photo of GA 12 & GA 83

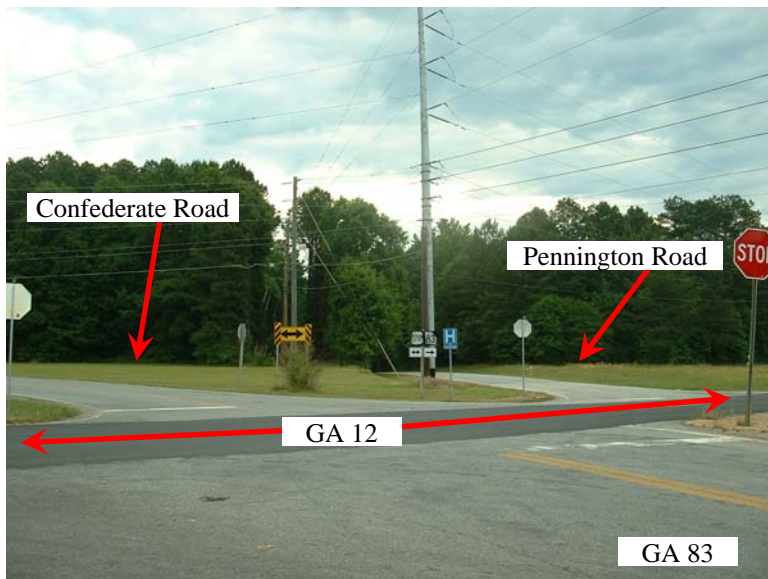

FIGURE 4-2
Looking North Toward Confederate Road and Pennington Road Approaches



FIGURE 4-3
Looking West (left photo) and East (right photo) from the GA 83 Approach



FIGURE 4-4
Northbound Approach of GA 83

4.2. GA 21 & GA 275 (#2, Effingham County)

Because of the distance from the other three candidate locations to GA 21 & GA 275, this intersection could not be included in the field reviews. Also, district staff shared that the intersection was scheduled for installation of a traffic signal. Because of this, this intersection was no longer a candidate for data collection of driver behavior and possible implementation.

4.3. GA 54 & GA 154 (#3, Coweta County)

The intersection of GA 54 & GA 154 is located in the town of Sharpsburg (2000 Census Population = 315). In the land adjacent to the intersection, there is a bank (southwest quadrant), gas station (northwest quadrant) and a tire service station (southeast quadrant). Both roadways are two-lane highways and no turn lanes have been constructed at the intersection. The posted

speed limit for GA 54 is 45 mph and 35 mph on GA 154. Intersection lighting is provided at the intersection (visible in **Figure 4-5**), otherwise the intersection was unimproved.

The area was relatively flat with no horizontal curves, providing drivers stopped at the intersection with sufficient sight distance. Despite this, the line of sight for a driver stopped on the west approach of GA 154 was obstructed by a bush and parked vehicles if he/she stopped at the STOP sign (left photo of **Figure 4-6**). However, if the driver were to pull slightly ahead of the STOP sign, then the view was no longer obstructed (right photo of **Figure 4-6**).

The review team met with district staff at the intersection. The district staff shared that the intersection was scheduled for installation of a traffic signal and installation of some turn lanes. Because of this, this intersection is not a quality candidate for data collection of driver behavior and possible instrumentation.



FIGURE 4-5
On GA 54 Looking North at Candidate Intersection



FIGURE 4-6
On West Approach of GA 154, Improved Sight Distance if Driver Creeps Past STOP Sign

4.4. GA 61 & GA 140 (#4, Bartow County)

The intersection of GA 61 (also marked as US Highway 411) & GA 140 is located in a rural portion of Bartow County. GA 61 is a rural, two-lane highway with a posted speed limit of 55 mph. At the intersection, GA 61 left and right turn lanes are provided for both approach directions (visible in **Figure 4-7**). GA 140 is also a rural two-lane highway with a 55 mph speed limit, but both approaches are stop controlled. Both approaches of GA 140 also include a channelized right turn lane with a YIELD sign (**Figure 4-8 and 4-9**).

An active railroad line closely parallels GA 61 to the west, creating an at-grade railroad crossing in close proximity to the intersection (**Figure 4-8**). Because of this, deployment of a IDS system at this location must be able to also sense when a train is approaching and the gates are down. That way, a driver stopped on the east approach and planning to cross GA 61 wouldn't be given a message that it is safe to cross while the gates are down.



FIGURE 4-7

Looking South (left photo) and North (right photo) from the East Approach of GA 140



FIGURE 4-8

GA 140 Eastbound Approach (left photo) and Channelized Right Turn Lane (right photo)



FIGURE 4-9
View of Railroad Crossing from the East Approach of GA 140

At this location, the crash diagrams in **Appendix A** show that an overwhelming majority of the crossing path crashes involve a driver from the east approach crossing GA 61. Also, many of these crashes involve a vehicle southbound on GA 61. The photos in **Figure 4-7** and **Figure 4-9** demonstrate that the line of sight for these drivers is not obstructed and sufficient sight distance is available. There is a combination horizontal and vertical curve located north of the intersection which may be creating difficulties in identification and selection of a safe lag. This crash pattern is an area of particular interest that could be investigated as part of collection of driver behavior data.

5. Summary and Intersection Recommendation

A summary of the pertinent crash statistics has been summarized in **Table 5-1** and **Table 5-2** for the four candidate intersections. Following is a set of general observations from the analysis and review of the Georgia candidate intersections.

- GDOT has applied various safety countermeasures in the traffic safety toolbox at these intersections. It appears these countermeasures (minor street improvements such as STOP AHEAD sign; transverse rumble strips; street lights; and advance guide and route signs, including railroad crossing warnings at one intersection which should help increase a driver's awareness) have been very effective at reducing intersection recognition crashes at many of these locations, but have not been effective at addressing lag related crashes – a crash type which is over represented at the highest crash frequency intersections in the State.
- The crash characteristics for the subset of high crash frequency intersections examined are very similar to the data for comparable intersections in Minnesota. The intersections have a crash rate greater than the critical crash rate (statistically significantly different than the expected value), the distribution of crash types is skewed to angle crashes, lag related, more severe than expected, and typically not caused by weather and/or light conditions.
- There is a complicating geometric or traffic pattern at two of the intersections – vertical curve, horizontal curve, or five approach legs. However, the actual intersection sight distance at each intersection appears to be consistent with AASHTO guidelines.
- Overall, many of the at-fault drivers are local to the area (live within 30 miles of crash location).

5.1. Recommended Intersection for Deployment

It was discovered after selecting and reviewing the four candidate intersections, that two of them had already been programmed for improvements within the next five years. Below is a list of the candidate intersections programmed for improvements:

- GA 21 & GA 275 (#2)—traffic signal to be installed.
- GA 54 & GA 154 (#3)—traffic signal to be installed in 2006 along with widening of the road.

Recommended Site: Of the remaining two intersections, GA 61 & GA 140 (#4) had the higher crash rate, a greater percentage of crossing path crashes, and the most crossing path crashes. GA 61 & GA 140 (#4) also had more severe crossing path crashes (i.e., fatal and visible injury) and lag recognition crashes (although GA 12 & GA 83 (#1) had a higher percentage of crossing path crashes that were classified as lag recognition). There were more older at-fault drivers at GA 12 & GA 83 (#1), but older drivers were still overrepresented at GA 61 & GA 140 (#4). Furthermore, GA 12 & GA 83 (#1) was a less desirable candidate intersection because of the complex, five-legged intersection geometry.

Therefore, the intersection recommended for data collection and potential deployment of the IDS system is GA 61 & GA 140 (#4). At this time, it is expected that the next phase of the study

(deployment of the temporary vehicle surveillance system at this intersection) will occur in the spring of 2006.

TABLE 5-1
Georgia Intersection Summary – 2000-2002

Performance Measure	GA 12 & GA 83 (#1)	GA 21 & GA 275 (#2)	GA 54 & GA 154 (#3)	GA 61 and GA 140 (#4)
Crash Frequency	13	21	21	21
Crash Severity				
Fatal	0 (0%)	0 (0%)	0 (0%)	0 (0%)
Visible Inj	3 (23%)	7 (33%)	1 (5%)	7 (33%)
Complaint Inj	5 (38.5%)	8 (38%)	5 (24%)	5 (24%)
PD	5 (38.5%)	6 (29%)	15 (71%)	9 (43%)
Daily Entering ADT	9,275	15,065	12,900	8,620
Crash Rate	1.3	1.3	1.5	2.2
Expected Rate	0.4 (MN)	0.4 (MN)	0.4 (MN)	0.4 (MN)
Critical Crash Rate	0.8	0.7	0.7	0.8
Correctable Crash Type	10 (77%)	15 (71%)	10 (48%)	17 (81%)
Crash Severity				
Fatal	0 (0%)	0 (0%)	0 (0%)	0 (0%)
Visible Inj	3 (30%)	4 (27%)	1 (10%)	6 (35%)
Complaint Inj	4 (40%)	6 (40%)	3 (30%)	4 (24%)
PD	3 (30%)	5 (33%)	6 (60%)	7 (41%)
At-Fault Driver				
< 21	2 (20%)	8 (53%)	5 (50%)	2 (12%)
21 – 64	3 (30%)	6 (40%)	3 (30%)	12 (70%)
> 64	5 (50%)	1 (7%)	2 (20%)	3 (18%)
Unknown	0 (0%)	0 (0%)	0 (0%)	0 (0%)
Crash Location				
Farside	1 (10%)	10 (67%)	6 (60%)	11 (65%)
Nearside	9 (90%)	5 (33%)	4 (40%)	6 (35%)
Contributing Factors				
Int Recg	0 (0%)	1 (7%)	0 (0%)	0 (0%)
Lag Recg	10 (100%)	13 (86%)	10 (100%)	15 (88%)
Other	0 (0%)	1 (7%)	0 (0%)	2 (12%)

TABLE 5-2

Georgia Intersection Summary – 2000-2005 (through September 30, 2005)

Performance Measure	GA 12 & GA 83 (#1)	GA 61 and GA 140 (#4)
Crash Frequency	26	34
Crash Severity		
Fatal	0 (0%)	1 (3%)
Visible Inj	3 (12%)	8 (24%)
Complaint Inj	6 (23%)	8 (24%)
PD	17 (65%)	17 (50%)
Daily Entering ADT	9,275	8,620
Crash Rate	1.3	1.9
Expected Rate	0.4 (MN)	0.4 (MN)
Critical Crash Rate	0.7	0.7
Correctable Crash Type	15 (58%)	27 (79%)
Crash Severity		
Fatal	0 (0%)	1 (4%)
Visible Inj	3 (20%)	7 (26%)
Complaint Inj	5 (33%)	7 (26%)
PD	7 (47%)	12 (44%)
At-Fault Driver		
< 21	2 (13%)	4 (15%)
21 – 64	6 (40%)	18 (67%)
> 64	6 (40%)	5 (19%)
Unknown	1 (7%)	0 (0%)
Crash Location		
Farside	3 (20%)	19 (70%)
Nearside	12 (80%)	8 (30%)
Contributing Factors		
Int Recg	0 (0%)	2 (7%)
Lag Recg	14 (93%)	22 (81%)
Other	1 (7%)	3 (11%)

5.2. Other Recommendations

If the IDS system is only deployed at GA 61 & GA 140 (#1), the remaining candidate intersection with no programmed improvements may benefit from traditional mitigation strategies to address the high number of crossing path crashes (especially those related to lag recognition). The following recommendation is presented for GDOT's consideration. However, further investigation is required to determine if this recommendation is a feasible solution or if another strategy may be optimal.

It was noted that at the time of the field review, there was a sufficient volume of traffic on GA 12 so that the number of safe lags was limited. To create more lags for vehicles on the minor street approaches, a traffic signal could be installed. Other improvements should also be included in such a project, such as adding turn lanes, realigning Confederate Road and Pennington Road to create a four-legged intersection, and a review

of traffic control devices to ensure the intersection is properly signed and marked. A second alternative is to install a modern roundabout. The implementation costs of a roundabout may be higher than a traffic signal, but the operational costs should be lower than a traditional traffic signal and a roundabout would be expected to provide additional safety benefit. A roundabout would also potentially allow the location to remain a five-legged intersection, avoiding realignment to the two local streets.

The two intersections programmed to be improved with a traffic signal should continue to be monitored to determine if the crash problem is adequately addressed.

The final recommendation is that GDOT consider an electronic database that has key intersection attributes (i.e., entering ADT volumes, roadway design, posted speed limit, area type, traffic control device, etc.) which can be queried and is also linked to the crash record database. Development of such a tool would allow the State to quickly and reliably screen through many intersections in order to determine expected rates and identify high crash locations.

References

1. W.J Najm, J.A. Koopmann and D.L. Smith. *Analysis of Crossing Path Crash Countermeasure Systems*. Proceedings of the 17th International Technical Conference on the Enhanced Safety of Vehicles, Amsterdam, The Netherlands. June 2001.
2. K.A. Harder, J. Bloomfield, B.J. Chihak. *Crashes at Controlled Rural Intersection*. Report MN/RC-2003-15. (St. Paul: Local Road Research Board, Minnesota Department of Transportation. July 2003.)
3. H. Preston, R. Storm, M. Donath, C. Shankwitz. *Review of Minnesota's Rural Intersection Crashes: Methodology for Identifying Intersections for Intersection Decision Support*. Report MN/RC-2004-31. (St. Paul: Minnesota Department of Transportation. May 2004.)
4. T. Maze, N. Hawkins, G. Burchett. *Rural Expressway Synthesis of Practice and Crash Analysis*. CTRE Project 03-157. (Ames: Iowa Department of Transportation. October 2004.)

Appendix A
Intersection Crash Diagrams

COLLISION DIAGRAM

LOCATION: GA 12 & GA 83 (MORGAN COUNTY) 1 OF 2

TIME PERIOD: 01/01/2000 - 09/30/2005

PREPARED BY: RJS DATE: 06-05-2006

No. of Accidents

Fatal=	0
Visible Injury=	3
Complaint Injury=	6
Injury Total=	9
Property Damage=	17
Total Accidents=	26

INDICATE NORTH



Confederate Road

Pennington Road

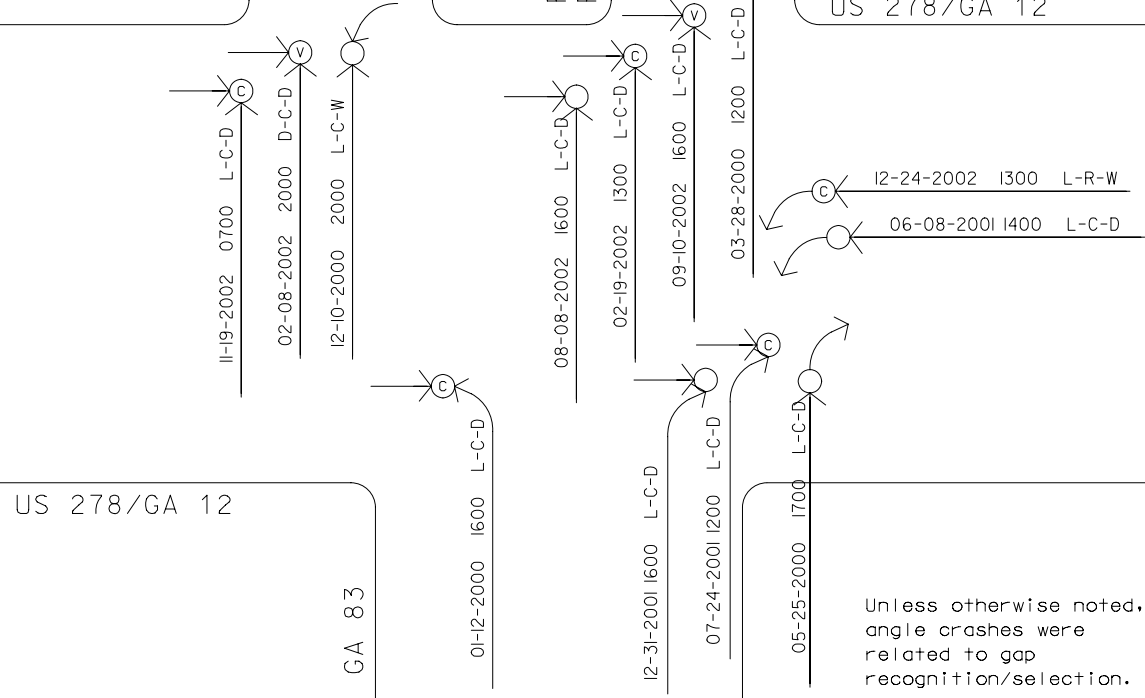
US 278/GA 12

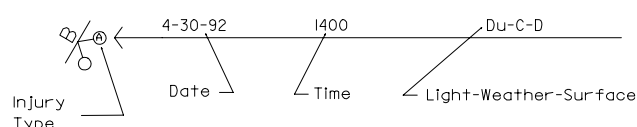

Unless otherwise noted, angle crashes were related to gap recognition/selection.

<ul style="list-style-type: none"> → Motor Vehicle Ahead ←←← Motor Vehicle Backing Up ⊘ Motor Vehicle Out of Control ⊙ Pedestrian ⊙ Bicycle/Moped ⊙ Motorcycle □ Fixed Object ⊙ Fatal Crash ⊙ Visible Injury Crash ⊙ Complaint Injury Crash 	<p>Light:</p> <p>L= Daylight DN= Dawn Du= Dusk D= Dark X= Unknown</p>	<p>Weather:</p> <p>C= Clear or Cloudy R= Rain S= Snow or Sleet X= Other or Unknown</p>
<ul style="list-style-type: none"> • Location/Details Unclear ○ Property Damage Crash ⊙ Rear End Property Damage ⊙ Right Angle Visible Injury 	<p style="text-align: center;">Example of Bicycle/Motor Vehicle Accident:</p>  <p style="font-size: small;">Injury Type Date Time Light-Weather-Surface</p>	

COLLISION DIAGRAM

LOCATION: GA 12 & GA 83 (MORGAN COUNTY) 2 OF 2

TIME PERIOD: 01/01/2000 - 09/30/2005

PREPARED BY: RJS DATE: 06-05-2006

No. of Accidents

Fatal=	0
Visible Injury=	3
Complaint Injury=	6
Injury Total=	9
Property Damage=	17
Total Accidents=	26

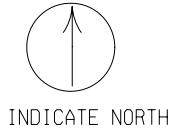

Confederate Road

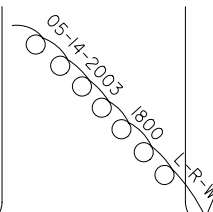

Pennington Road

US 278/GA 12

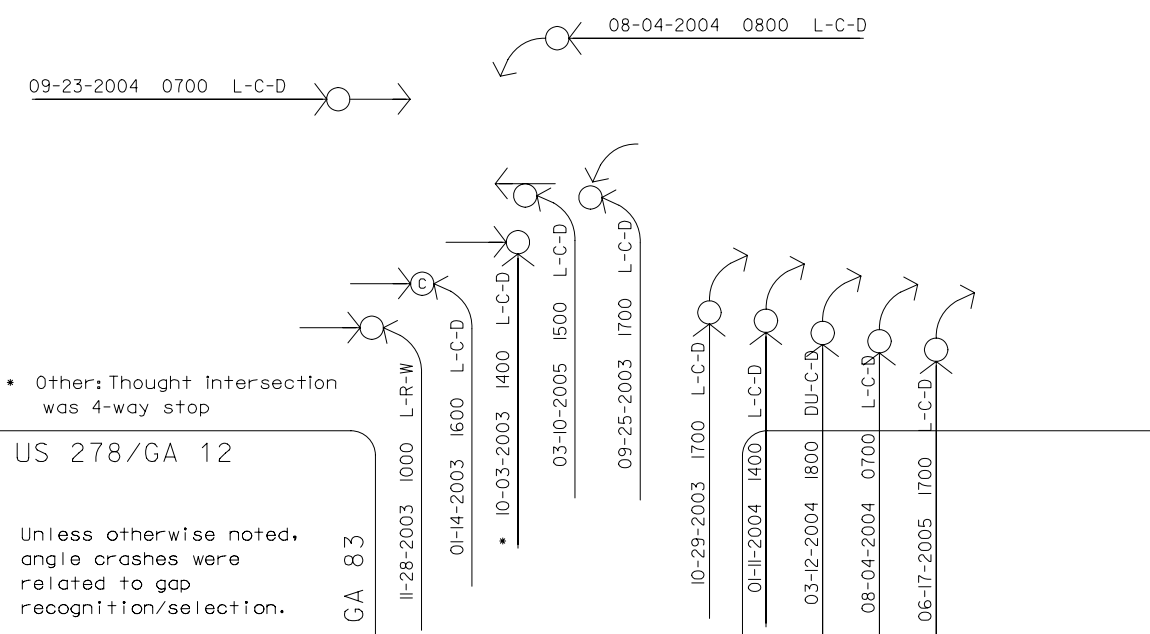

- Motor Vehicle Ahead
- ←←← Motor Vehicle Backing Up
- ⊘ Motor Vehicle Out of Control
- ⊙ Pedestrian
- ⊙ Bicycle/Moped
- ⊙ Motorcycle
- Fixed Object
- ⊙ Fatal Crash
- ⊙ Visible Injury Crash
- ⊙ Complaint Injury Crash
- * Location/Details Unclear
- Property Damage Crash
- ⊙ Rear End Property Damage
- ⊙ Right Angle Visible Injury

Light:
 L= Daylight
 DN= Dawn
 Du= Dusk
 D= Dark
 X= Unknown

Weather:
 C= Clear or Cloudy
 R= Rain
 S= Snow or Sleet
 X= Other or Unknown

Surface:
 D= Dry
 W= Wet
 S= Snow or Ice
 X= Other or Unknown

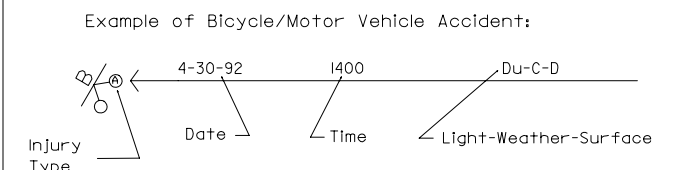

Collision Diagram

Location: GA 21 & GA 275 (Effingham County) 1 of 2

Time Period: 01/01/2000 - 12/31/2002

Prepared By: r.js Date: 08-19-2005

No. of Accidents

Fatal=	0
Visible Injury=	7
Complaint Injury=	8
Injury Total=	15
Property Damage=	7
Total Accidents=	22

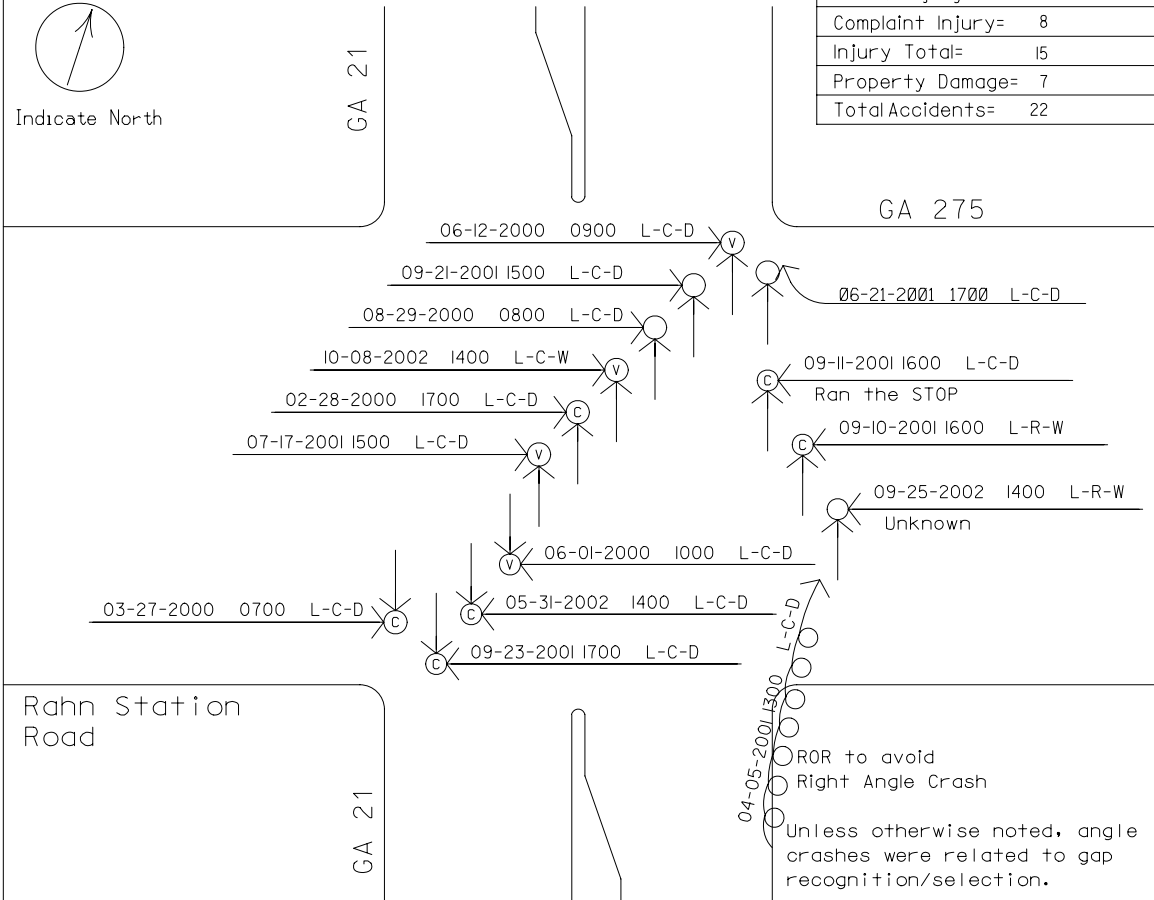
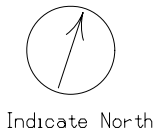

<ul style="list-style-type: none"> → Motor Vehicle Ahead ←←← Motor Vehicle Backing Up ⊞ Motor Vehicle Out of Control ⊙ Pedestrian ⊙ Bicycle/Moped ⊙ Motorcycle □ Fixed Object ⊙ Fatal Crash ⊙ Visible Injury Crash ⊙ Complaint Injury Crash 	<p>Light:</p> <p>L= Daylight DN= Dawn Du= Dusk D= Dark X= Unknown</p>	<p>Weather:</p> <p>C= Clear or Cloudy R= Rain S= Snow or Sleet X= Other or Unknown</p>
<ul style="list-style-type: none"> • Location/Details Unclear ○ Property Damage Crash ⊙ Rear End Property Damage ⊙ Right Angle Visible Injury 	<p style="text-align: center;">Example of Bicycle/Motor Vehicle Accident:</p>	

Collision Diagram

Location: GA 21 & GA 275 (Effingham County) 2 of 2

Time Period: 01/01/2000 - 12/31/2002

Prepared By: rjs Date: 08-19-2005

No. of Accidents

Fatal=	0
Visible Injury=	7
Complaint Injury=	8
Injury Total=	15
Property Damage=	7
Total Accidents=	22

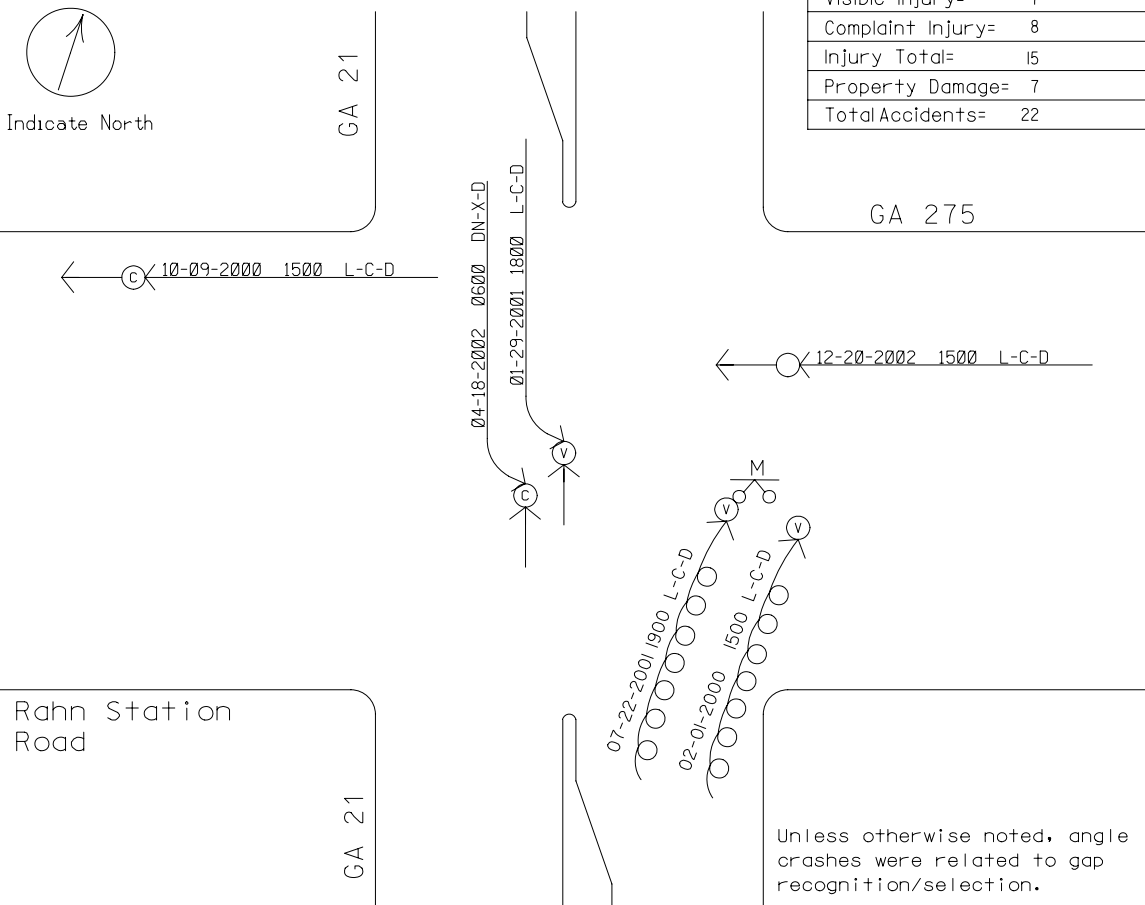

<ul style="list-style-type: none"> → Motor Vehicle Ahead ←←← Motor Vehicle Backing Up ⊞ Motor Vehicle Out of Control ⊙ Pedestrian ⊙ Bicycle/Moped ⊙ Motorcycle □ Fixed Object ⊙ Fatal Crash ⊙ Visible Injury Crash ⊙ Complaint Injury Crash 	<p>Light:</p> <p>L= Daylight DN= Dawn Du= Dusk D= Dark X= Unknown</p> <p>Weather:</p> <p>C= Clear or Cloudy R= Rain S= Snow or Sleet X= Other or Unknown</p> <p>Surface:</p> <p>D= Dry W= Wet S= Snow or Ice X= Other or Unknown</p>	<p>Location/Details</p> <ul style="list-style-type: none"> • Unclear ○ Property Damage Crash ⊙ Rear End Property Damage ⊙ Right Angle Visible Injury
<p>Example of Bicycle/Motor Vehicle Accident:</p>		

Collision Diagram

Location: GA 54 & GA 154 (Coweta County) 1 of 2

Time Period: 01/01/2000 - 12/31/2002

Prepared By: r.js Date: 08-19-2005

No. of Accidents

Fatal=	0
Visible Injury=	1
Complaint Injury=	5
Injury Total=	6
Property Damage=	15
Total Accidents=	21

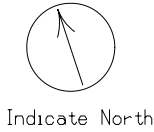

GA 154

GA 54

Mcintosh Trail

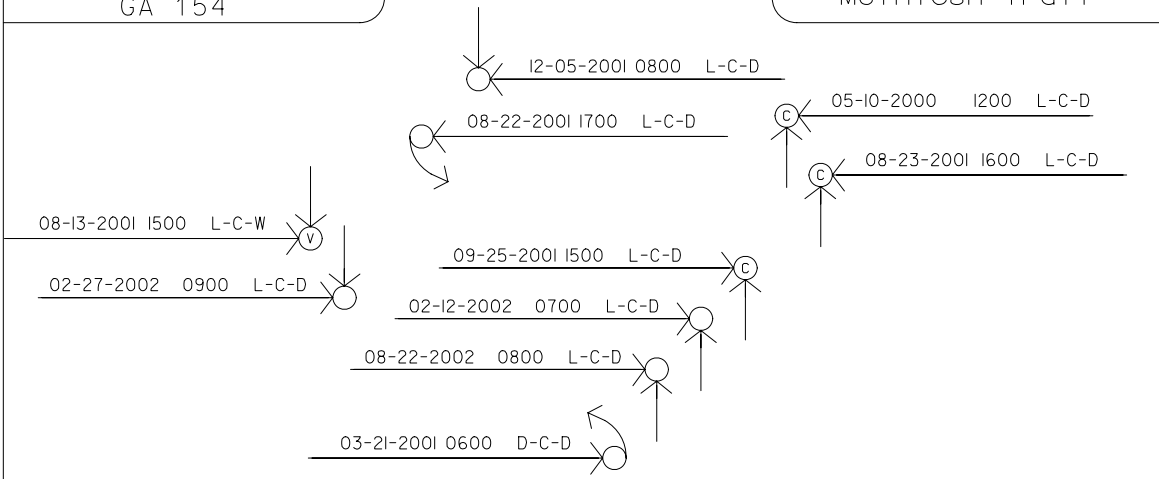

Unless otherwise noted, angle crashes were related to gap recognition/selection.

<ul style="list-style-type: none"> → Motor Vehicle Ahead ←←← Motor Vehicle Backing Up ⊞→ Motor Vehicle Out of Control ⊙ Pedestrian ⊙ Bicycle/Moped ⊙ Motorcycle □ Fixed Object ⊙ Fatal Crash ⊙ Visible Injury Crash ⊙ Complaint Injury Crash 	<p>Light:</p> <p>L= Daylight DN= Dawn Du= Dusk D= Dark X= Unknown</p>	<p>Weather:</p> <p>C= Clear or Cloudy R= Rain S= Snow or Sleet X= Other or Unknown</p>
<ul style="list-style-type: none"> * Location/Details Unclear ○ Property Damage Crash ⊙ Rear End Property Damage ⊙ Right Angle Visible Injury 	<p style="text-align: center;">Example of Bicycle/Motor Vehicle Accident:</p> <p style="text-align: center;">Injury Type Date Time Light-Weather-Surface</p>	

Collision Diagram

Location: GA 54 & GA 154 (Coweta County) 2 of 2

Time Period: 01/01/2000 - 12/31/2002

Prepared By: rjs Date: 08-19-2005

No. of Accidents

Fatal=	0
Visible Injury=	1
Complaint Injury=	5
Injury Total=	6
Property Damage=	15
Total Accidents=	21

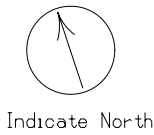

GA 154

GA 54

Mcintosh Trail

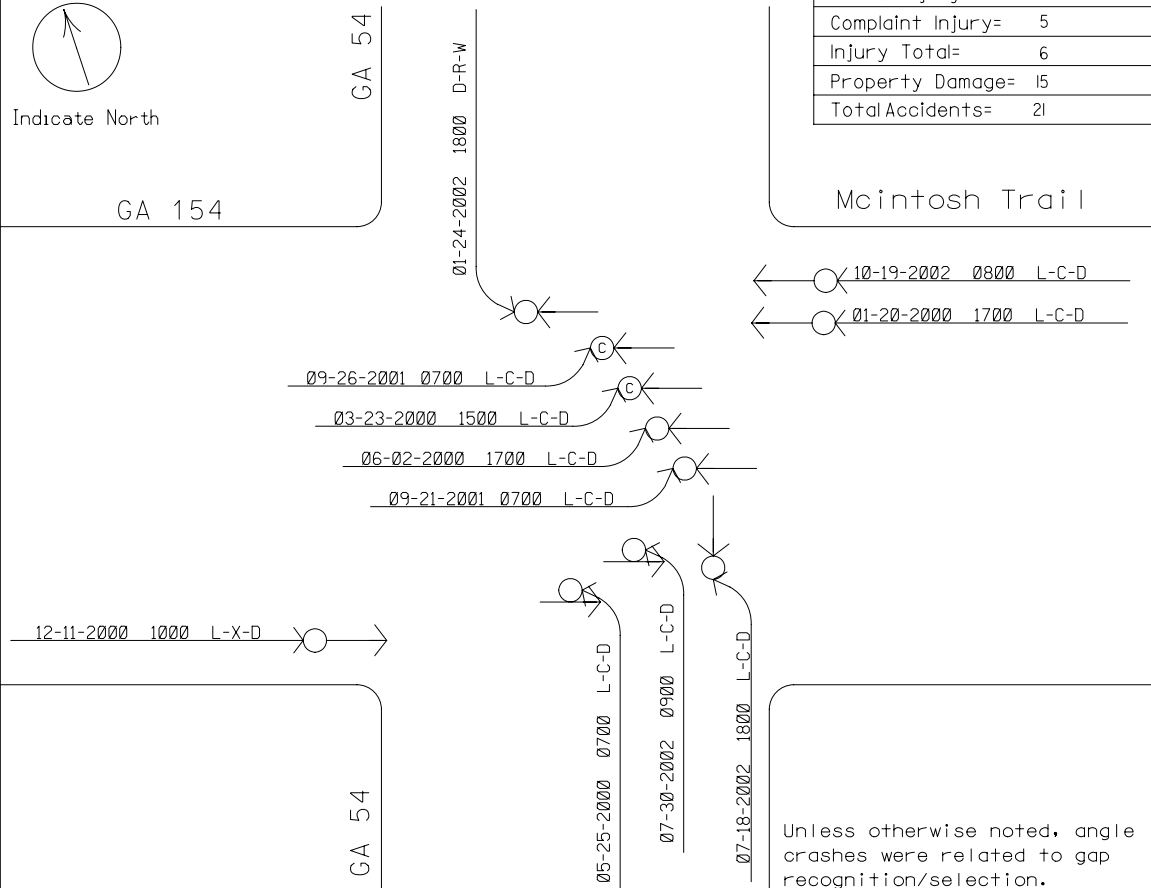

Unless otherwise noted, angle crashes were related to gap recognition/selection.

<ul style="list-style-type: none"> → Motor Vehicle Ahead ←←← Motor Vehicle Backing Up ⊖→ Motor Vehicle Out of Control ⊙ Pedestrian ⊙ Bicycle/Moped ⊙ Motorcycle □ Fixed Object ⊙ Fatal Crash ⊙ Visible Injury Crash ⊙ Complaint Injury Crash 	<p>Light:</p> <p>L= Daylight DN= Dawn Du= Dusk D= Dark X= Unknown</p>	<p>Weather:</p> <p>C= Clear or Cloudy R= Rain S= Snow or Sleet X= Other or Unknown</p>	<p>Surface:</p> <p>D= Dry W= Wet S= Snow or Ice X= Other or Unknown</p>
<p>Example of Bicycle/Motor Vehicle Accident:</p>			

COLLISION DIAGRAM

LOCATION: GA 61 & GA 140 (BARTOW COUNTY) 1 OF 3

TIME PERIOD: 01/01/2000 - 09/30/2005

PREPARED BY: RJS DATE: 06-05-2006

No. of Accidents

Fatal=	1
Visible Injury=	8
Complaint Injury=	8
Injury Total=	16
Property Damage=	17
Total Accidents=	34



GA 140

US 411/GA 61

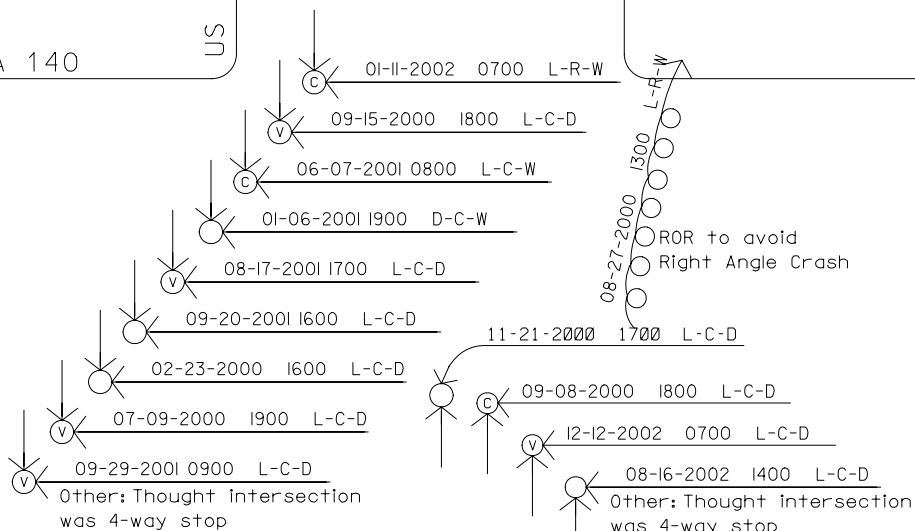

Other: Thought intersection was 4-way stop

Other: Thought intersection was 4-way stop

GA 140

US 411/GA 61

Unless otherwise noted, angle crashes were related to gap recognition/selection.

<ul style="list-style-type: none"> → Motor Vehicle Ahead ←←← Motor Vehicle Backing Up ⊖ Motor Vehicle Out of Control ⊙ Pedestrian ⊙ Bicycle/Moped ⊙ Motorcycle □ Fixed Object ⊙ Fatal Crash ⊙ Visible Injury Crash ⊙ Complaint Injury Crash 	<p>Light:</p> <p>L= Daylight DN= Dawn Du= Dusk D= Dark X= Unknown</p>	<p>Weather:</p> <p>C= Clear or Cloudy R= Rain S= Snow or Sleet X= Other or Unknown</p>
<ul style="list-style-type: none"> * Location/Details Unclear ○ Property Damage Crash ⊙ Rear End Property Damage ⊙ Right Angle Visible Injury 	<p style="text-align: center;">Example of Bicycle/Motor Vehicle Accident:</p>	

COLLISION DIAGRAM

LOCATION: GA 61 & GA 140 (BARTOW COUNTY) 2 OF 3

TIME PERIOD: 01/01/2000 - 09/30/2005

PREPARED BY: RJS DATE: 06-05-2006

No. of Accidents

Fatal=	1
Visible Injury=	8
Complaint Injury=	8
Injury Total=	16
Property Damage=	17
Total Accidents=	34

 INDICATE NORTH

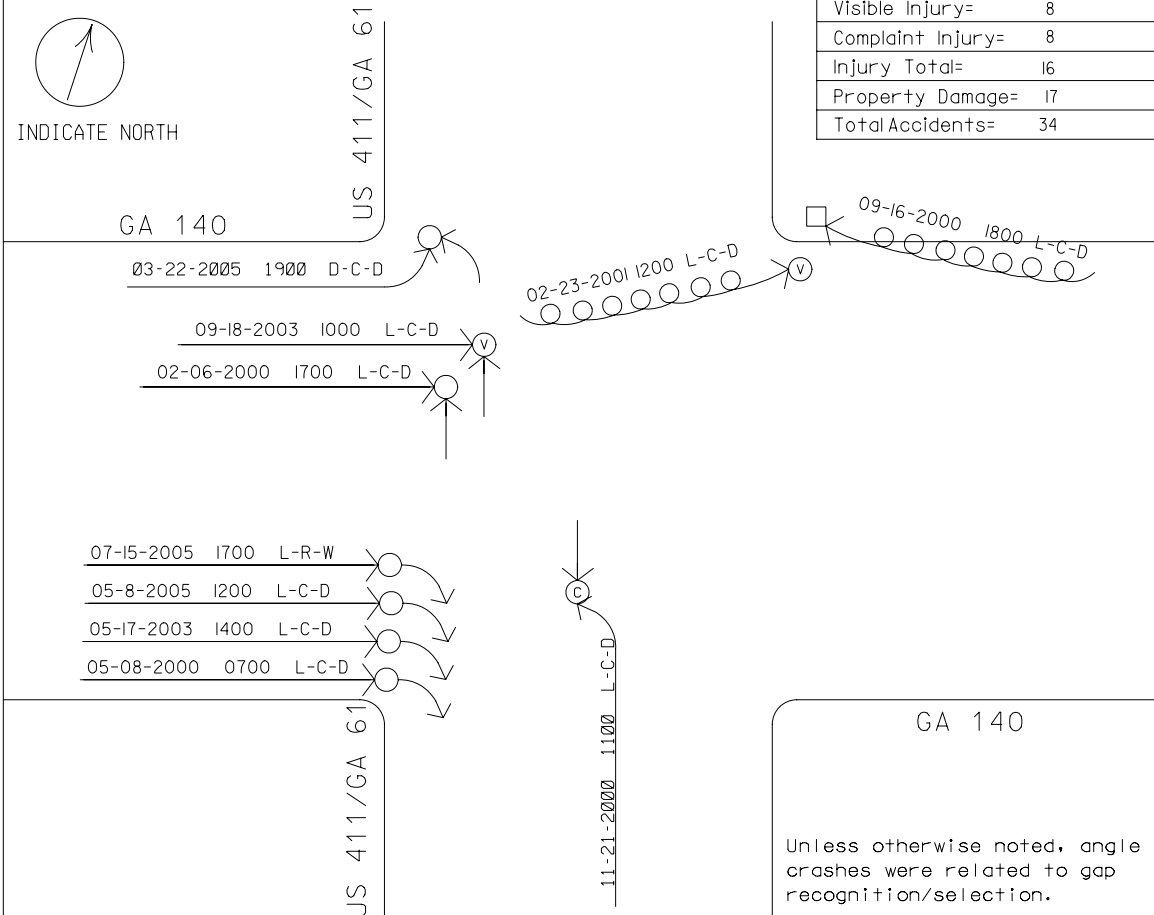

Unless otherwise noted, angle crashes were related to gap recognition/selection.

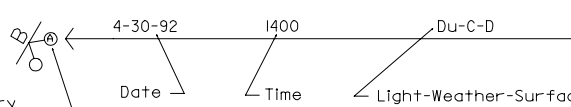
<ul style="list-style-type: none"> → Motor Vehicle Ahead ←←← Motor Vehicle Backing Up ⊞ Motor Vehicle Out of Control ⊙ Pedestrian ⊙ Bicycle/Moped ⊙ Motorcycle □ Fixed Object ⊙ Fatal Crash ⊙ Visible Injury Crash ⊙ Complaint Injury Crash 	<p>Light:</p> <ul style="list-style-type: none"> L= Daylight DN= Dawn Du= Dusk D= Dark X= Unknown 	<p>Weather:</p> <ul style="list-style-type: none"> C= Clear or Cloudy R= Rain S= Snow or Sleet X= Other or Unknown
<ul style="list-style-type: none"> * Location/Details Unclear ○ Property Damage Crash ⊙ Rear End Property Damage ⊙ Right Angle Visible Injury 	<p style="text-align: center;">Example of Bicycle/Motor Vehicle Accident:</p> <div style="text-align: center;">  </div>	

COLLISION DIAGRAM

LOCATION: GA 61 & GA 140 (BARTOW COUNTY) 3 OF 3

TIME PERIOD: 01/01/2000 - 09/30/2005

PREPARED BY: RJS DATE: 06-05-2006

No. of Accidents

Fatal=	1
Visible Injury=	8
Complaint Injury=	8
Injury Total=	16
Property Damage=	17
Total Accidents=	34

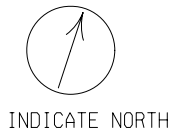

GA 140

US 411/GA 61

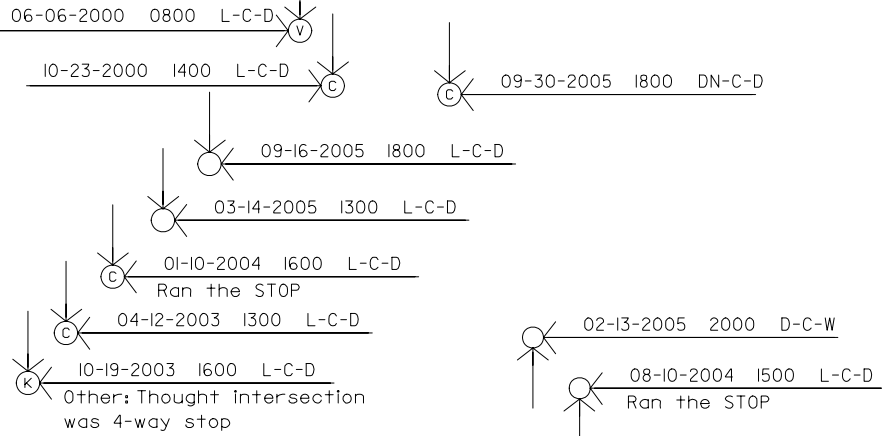

GA 140

Unless otherwise noted, angle crashes were related to gap recognition/selection.

- Motor Vehicle Ahead
- ←←← Motor Vehicle Backing Up
- ⊞→ Motor Vehicle Out of Control
- ⊙ Pedestrian
- ⊙ Bicycle/Moped
- ⊙ Motorcycle
- Fixed Object
- ⊙ Fatal Crash
- ⊙ Visible Injury Crash
- ⊙ Complaint Injury Crash
- Location/Details
- Unclear
- Property Damage Crash
- ⊙ Rear End Property Damage
- ⊙ Right Angle Visible Injury

Light:
 L= Daylight
 DN= Dawn
 Du= Dusk
 D= Dark
 X= Unknown

Weather:
 C= Clear or Cloudy
 R= Rain
 S= Snow or Sleet
 X= Other or Unknown

Surface:
 D= Dry
 W= Wet
 S= Snow or Ice
 X= Other or Unknown

Example of Bicycle/Motor Vehicle Accident:

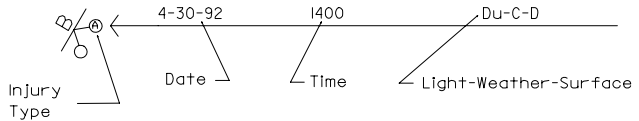

Appendix B
Aerial Photographs

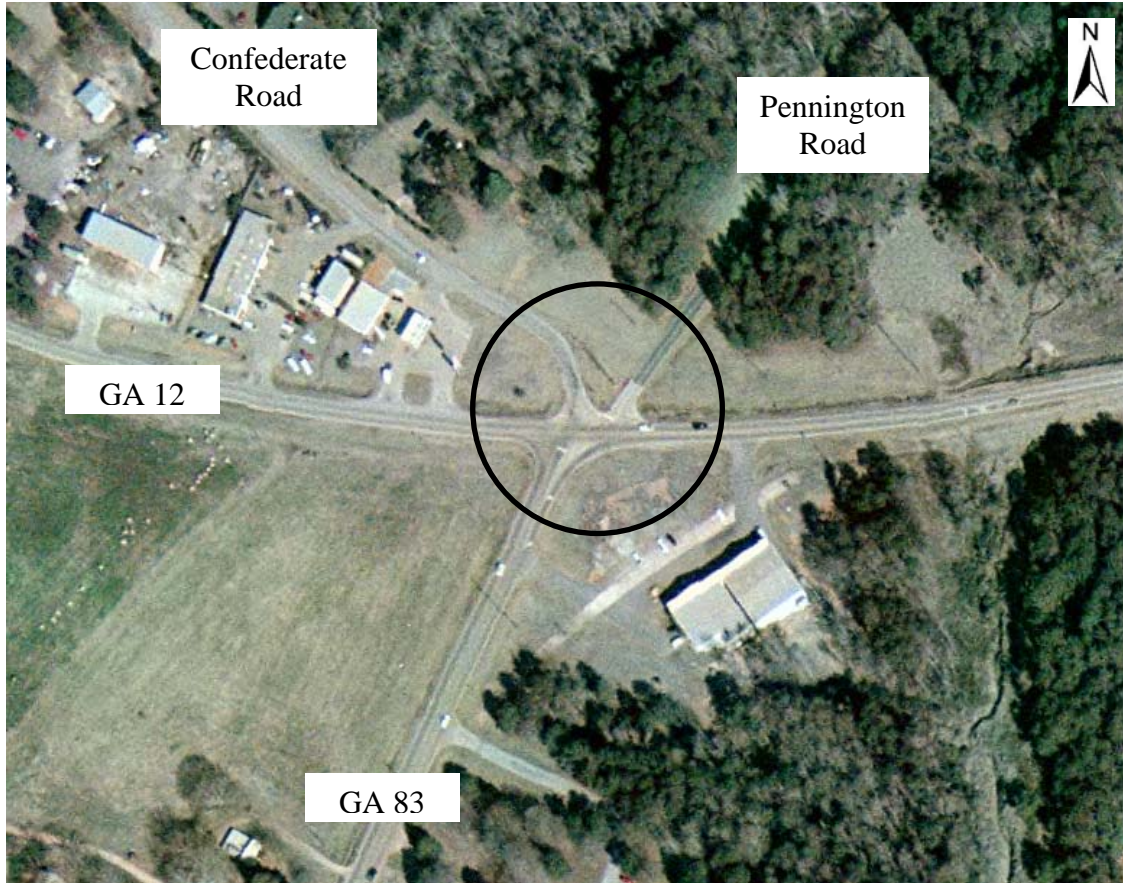

FIGURE B-1
Aerial Photo of GA 12 & GA 83 (#1)
Source: Georgia DOT



FIGURE B-2
Aerial Photo of GA 21 & GA 275 (#2)
Source: Eaton County



FIGURE B-3
Aerial Photo of GA 54 & GA 154 (#3)
Source: Georgia DOT

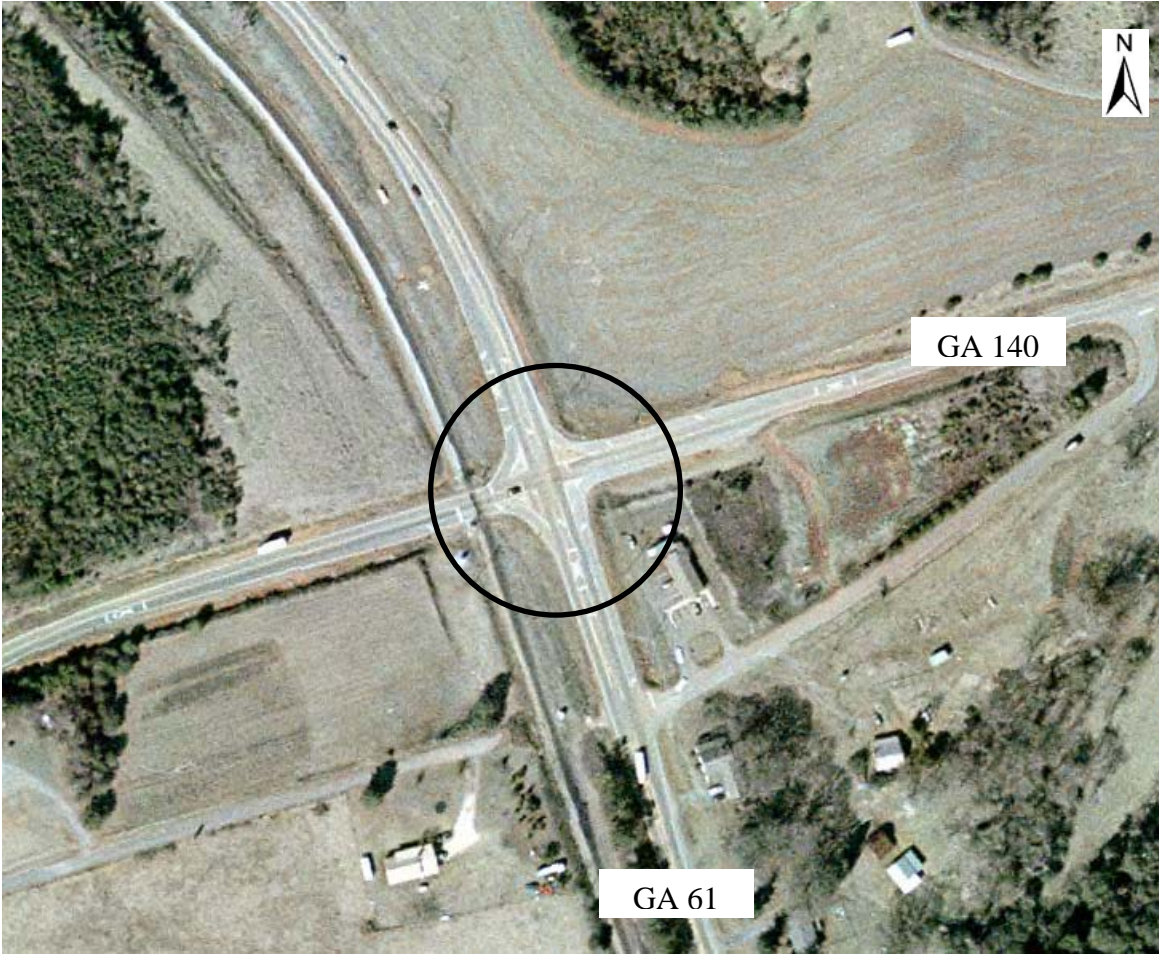

FIGURE B-4
Aerial Photo of GA 61 & GA 140 (#4)
Source: Georgia DOT